

Field Manual
No. 44-44

***FM 44-44**
Headquarters
Department of the Army
Washington, DC, 3 October 1995

AVENGER PLATOON, SECTION, AND SQUAD OPERATIONS

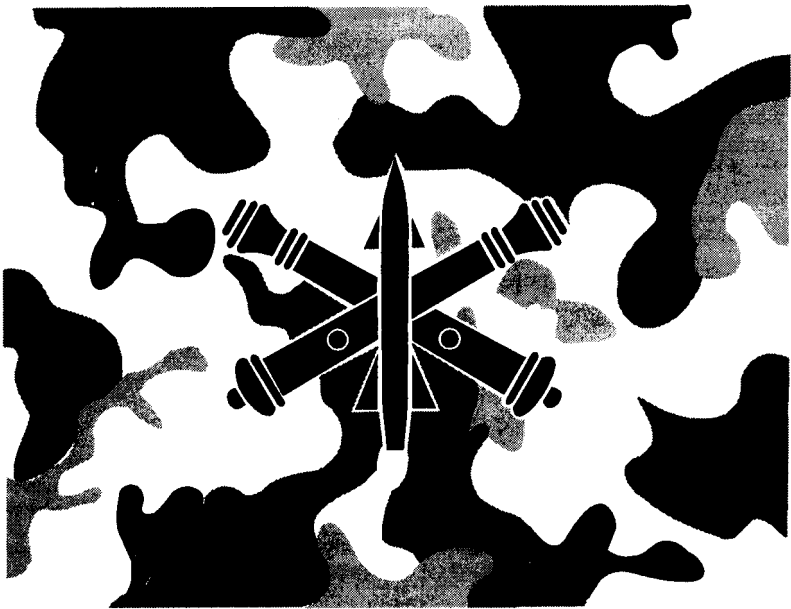

DISTRIBUTION RESTRICTION: Approved for public release distribution is unlimited.

*This publication supersedes FM 44-31, 13 June 1990.

Contents

Page

Chapter	1	Avenger Platoon Operations and Organization	1-1
	2	Command, Control, and Communications	2-0
	3	Force-Projection Operations	3-1
	4	Offensive and Defensive Operations.....	4-0
	5	Other Operations.....	5-0
	6	Logistics	6-0
Appendix	A	Air Defense Orders and Annexes	A-1
	B	Combined Arms for Air Defense	B-1
	C	Reconnaissance, Selection, and Occupation of Position.....	C-0
	D	Avenger Platoon, Section, and Squad Checklists	D-1
	E	Early Warning	E-1
	F	Combat Operations in Varied Environments	F-1
	G	Limited Visibility Operations	G-0
	H	Nuclear, Biological, and Chemical Operations	H-0
	I	Air IPB in Support of Avenger Operations	I-0
	J	Maps and Control Measures	J-1
	K	The Engagement Systems	K-1
	L	Safety and Risk Assessment	L-0
Glossary		Glossary-1	
References		References-1	
Index		Index-1	

Preface

The mission of air defense artillery is to protect the force and selected geopolitical assets from aerial attack, missile attack, and surveillance. FM 44-44 is the doctrinal forward area air defense (FAAD) manual for the Avenger platoon, section, and squad. It explains how Avenger provides air defense for the force and survives on the battlefield.

This manual also details tactics, techniques, and procedures used by the Avenger platoon when engaged in decisive offensive and defensive operations. Most importantly, it describes how Avenger platoons, sections, and squads protect deploying or deployed forces and critical assets by preventing enemy aerial platforms (unmanned, rotary, and fixed wing) and missiles from locating, striking, and destroying them.

This manual is required reading for commanders, platoon leaders, platoon sergeants, and section and squad leaders who will direct and supervise the employment of Avenger weapon systems. Other recommended essential reading includes—

- FM 7-8 Infantry Rifle Platoon and Squad
- FM 7-20 The Infantry Battalion
- FM 7-30 Infantry, Airborne, and Air Assault Brigade Operations
- FM 44-43 Bradley Stinger Fighting Vehicle Platoon and Squad Operations
- FM 44-64 FAAD Battalion and Battery Operations (TBP)
- FM 44-100 US Army Air Defense Operations
- FM 71-1-1 Tank and Mechanized Infantry Company Team
- FM 71-2 The Tank and Mechanized Infantry Battalion Task Force
- FM 71-3 Armored and Mechanized Infantry Brigade
- FM 71-123 Tactics and Techniques for Combined Arms Heavy Forces: Armored Brigade, Battalion/Task Force, and Company/Team

FM 44-44 is unclassified. Therefore, threat information contained in the publication is general in nature. Where detailed and current information is required, consult authoritative threat sources. Classified information pertaining to Avenger capabilities, limitations, and AD planning is found in (S)FM 44-100A(U)(TBP).

This publication implements the following international standardization agreements (STANAGs):

STANAG	TITLE	EDITION
2014	Operation Orders, Warning Orders, and Administrative/Logistics Orders	7
2019	Military Symbols for Land Based Systems (APP-6)	3
2034	Land Forces Procedures for Allied Supply Transactions	4
2041	Operations Orders, Tables and Graphs for Road Movement	4
3700	NATO Tactical Air Doctrine—ATP-33 (B)	4
3736	Offensive Air Support Operations—ATP-27 (B)	8
3805	Doctrine & Procedures for Airspace Control in Times of Crisis and War—ATP40 (A)	4
3880	Counter Air Operations—ATP-42 (B)	2

The proponent of this publication is the United States Army Air Defense Artillery School. Send comments and recommendations on DA Form 2028 directly to Commandant, US Army Air Defense Artillery School, ATTN: ATSA-TAC-D, Fort Bliss, TX 79916-3802.

Unless this publication states otherwise, masculine nouns and pronouns do not refer exclusively to men.

CHAPTER 1
**AVENGER PLATOON OPERATIONS
AND ORGANIZATION**

This chapter discusses missions, capabilities, organization, and roles of the Avenger platoon. The Avenger plays an integral role in the combined arms team, especially with winning the information war. The Avenger missions are to counter enemy RISTA efforts and to provide low-altitude air defense to the force and its critical assets.

The Army ADA mission is to protect the force and selected geopolitical assets from aerial and missile attack and surveillance. The Avenger platoon leader must understand Army operations doctrine so that the platoon's employment is synchronized with the supported force's main effort. The FAAD mission is to provide low-altitude air defense protection to the force and its critical assets. FAAD contributes to force-protection operations by countering threat RISTA and lethal aerial platforms. FAAD weapon systems ensure the force has the freedom to maneuver during combat operations.

CONTENTS

	Page
Platoon in Army Operations	1-2
Organization of Platoon	1-3
Platoon Personnel Responsibilities	1-4
Characteristics and Capabilities	1-6
Components	1-7

PLATOON IN ARMY OPERATIONS

FM 100-5 describes how the Army organizes and applies combat power and synchronizes operating systems on the battlefield to achieve victory. There are five tenets which describe the characteristics of a successful operation. These tenets apply to all leaders of combat, combat support, and combat service support organizations. The Avenger leader must practice and train within these tenets to be successful on the battlefield.

INITIATIVE

Initiative sets or changes the terms of battle by action and implies an offensive spirit in the conduct of all operations. Initiative requires that leaders anticipate events on the battlefield so that they and their units can act and react faster than the enemy. Applied to individual soldiers and leaders, initiative requires a willingness and ability to act independently within the framework of the commander's intent. The Avenger platoon must be able to anticipate enemy actions and organize its assets to defeat or destroy the enemy air threat before the air threat can negatively impact the friendly force or asset.

AGILITY

Agility is the ability of friendly forces to react faster than the enemy and is a prerequisite for seizing and holding the initiative. It is as much

a mental as a physical quality. For the Avenger platoon, agility is the ability to adjust platoon coverage to meet varying air threats. The decision support matrix (DSM) and the execution matrix are examples of tools that the Avenger platoon leader may use to achieve agility through rapid concentration of air defense weapons against enemy air platforms.

DEPTH

Depth is the extension of operations in time, space, resources, and purpose. It is the ability to gain information and influence operations throughout the battlefield. The Avenger platoon achieves depth by using air defense direct fire and early warning assets throughout the entire supported unit's area of operations.

SYNCHRONIZATION

Synchronization is arranging activities in time and space to mass at the decisive point. It requires a clear understanding of the supported unit commander's intent. The Avenger platoon achieves synchronization by massing fires at the critical point on the battlefield. An example of synchronization for the Avenger platoon is the proper positioning of fire units (FUs) on the battlefield to mass fires at the critical point, according to the supported commander's intent, to destroy or defeat any enemy air threat.

VERSATILITY

Versatility is the ability to meet diverse mission requirements. The Avenger platoon must be flexible to meet diverse mission requirements.

An example of versatility for an Avenger platoon is the ability to transition quickly from a defensive to an offensive mission.

ORGANIZATION OF PLATOON

The Avenger platoon is organic to divisional ADA battalions, armored cavalry regiments, and ADA brigades. The platoon must support a wide variety of missions dependent on the supported unit.

The Avenger platoon is configured into two different organizational structures. The Avenger Platoon Organization illustration depicts an Avenger platoon that consists of a platoon headquarters (HQ) and three Avenger sections. Units may configure their platoons into two

sections of three squads, based on METT-T, but the next two illustrations depict the correct doctrinal platoon structure. The platoon HQ consists of the platoon leader, platoon sergeant, and two driver-radio operators. The Avenger section consists of two squads with one FU per squad. The senior sergeant is the section leader and is also a squad leader for one of the squads. Each squad consists of a driver and gunner.

ADA battalions in heavy divisions, ACRs, and separate heavy

AVENGER PLATOON ORGANIZATION

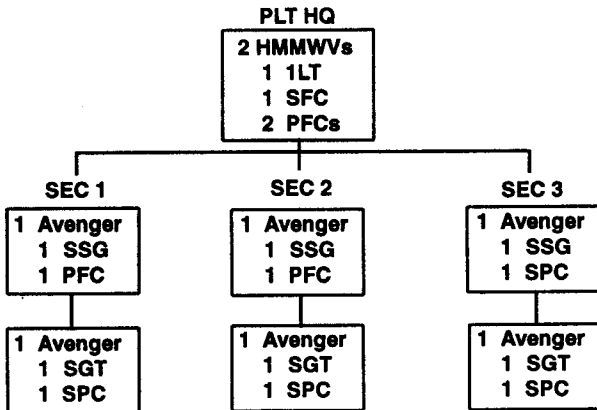

brigades have four FUs per platoon as depicted in the following illustration. All

others have six FUs per platoon as previously shown.

PLATOON PERSONNEL RESPONSIBILITIES

The responsibilities of personnel assigned to Avenger platoons are diverse. This section outlines the general responsibilities of the platoon personnel.

PLATOON LEADER

The Avenger platoon leader has dual responsibilities. He commands the Avenger platoon and in this capacity is responsible for its tactical employment and logistics. He may also be the special staff officer for air defense for the supported unit commander.

PLATOON SERGEANT

The platoon sergeant is second in command of the platoon. He must be proficient in all of the tasks normally accomplished by the platoon leader and be prepared to assume the platoon leader's responsibilities at a moment's notice. He must ensure that subordinate leaders are trained to perform leader duties two levels above their position in addition to their normal duties. He is responsible for the discipline and coordination of all logistics and maintenance support the platoon requires. The platoon

AVENGER PLATOON ORGANIZATION- HEAVY DIVISION

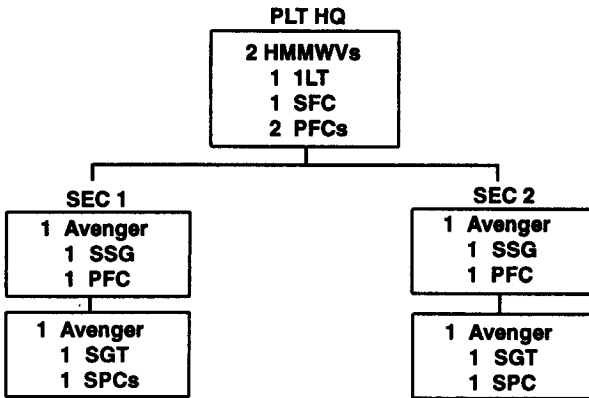

sergeant must work in close coordination with the platoon leader to ensure unity of effort.

SECTION LEADER (DRIVER)/ SQUAD LEADER (DRIVER)

The section leader may assume duties and responsibilities similar to the platoon leader when a section is task-organized separately from the Avenger platoon. He may be the air defense officer (ADO) for the supported unit, responsible for coordination with the staff. However, the Avenger section leader's primary responsibility is FU employment.

The section or squad leader has overall responsibility for the section or squad. The section or squad leader designates targets, routes of movement, and vehicle positions; determines weapons to be fired; and issues fire commands. He also maintains communications and carries out the platoon leader's or platoon sergeant's directives. The section or squad leader has primary responsibility for the maintenance of the Avenger and the training of his section or squad.

The section or squad leader has overall responsibility for his Avenger weapon system. The section or squad leader observes the battlefield to detect and identify targets. He issues fire control orders based on the current rules of engagement (ROE). The section leader is responsible for the proper emplacement of his assigned

weapon system. The section or squad leader is also the primary driver.

GUNNER

The gunner observes the battlefield to detect and identify targets. The gunner is the primary operator of the weapon system. He is responsible for assisting the section or squad leader in the operation and maintenance of the Avenger weapon system. He must be prepared to assume all the duties and responsibilities of the section or squad leader.

BATTLE CAPTAIN CONCEPT

The battle captain concept is a technique used to assist the ADO and PSG in C² and logistics throughout planning, preparation, and execution. He is usually the senior section leader and is especially useful in helping the PSG transition to the platoon leader job. He can brief the PSG on the current tactical situation should the PSG have to become the platoon leader. The battle captain can also assist the platoon leader with all aspects of planning, preparation, and execution. His involvement can enhance command and control. The battle captain's responsibilities are as follows:

- Prepares to assume duties as PSG.
- Briefs PSG on current tactical situation (platoon and supported unit) to assist PSG's

Avenger operations. See the Stinger Technical Data illustration on page 1-6. For more information, see TM 9-1425-433-10.

**M3P .50-CALIBER
MACHINE GUN**

The machine gun allows for aerial target engagement within the missile's dead zone and is also used for self-defense. See the illustration on bottom of page 1-6.

The M3P machine gun has limited range and only 200 available rounds. Due to limited ammunition

supply onboard, strict firing discipline is essential. The machine gun has a no-fire zone from positive 10 degrees to negative 10 degrees in elevation, and a cutout zone from 270 to 18 degrees in azimuth toward the front of the HMMWV. The turret is mounted on a modified M998 or M1097 HMMWV. The HMMWV provides good mobility over all types of terrain. The Avenger system is powered by two 12-volt system batteries that can be monitored on the HMMWV electrical system.

COMPONENTS

Platoon members must be knowledgeable of the Avenger's characteristics and capabilities. All platoon members must actively seek

to minimize the Avenger's limitations to maximize its combat effectiveness on the battlefield. See the Avenger Components illustration.

AVENGER COMPONENTS

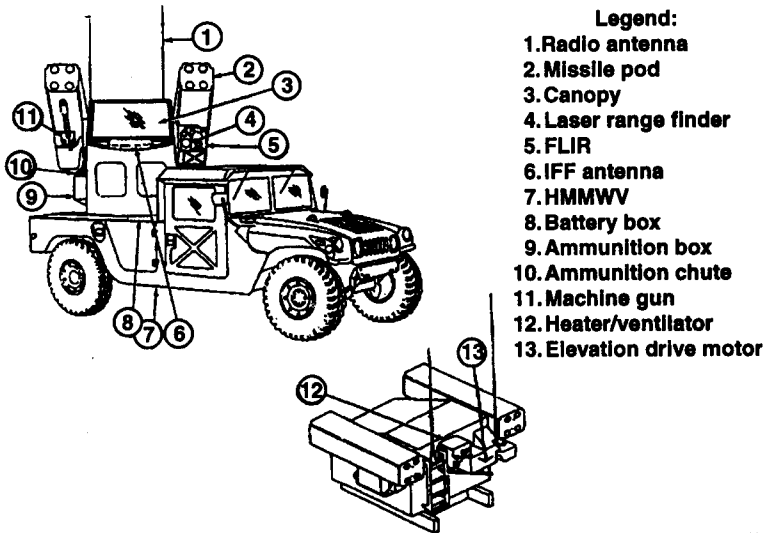

ADDITIONAL CAPABILITIES AND CHARACTERISTICS

Avenger fire power and shoot-on-the-move capabilities tremendously enhance air defense protection for maneuver forces throughout the battlefield. This section addresses Avenger's added capabilities and mobility for survivability.

Turret (Gunner's Station)

The Avenger turret provides the gunner with unobstructed fields of view rotating through 360 degrees in azimuth and from negative 10 degrees to positive 68 degrees in elevation. An SVML is mounted on each side of the turret. Each pod holds four missiles. The load and reload time for eight missiles is six minutes (or seven minutes in MOPP 4).

M3P .50-Caliber Machine Gun

The M3P .50-caliber machine gun includes an ammunition box, a soft recoil mount, a remote charger, a flexible feed chute, and a brass and link collector.

Sensors

The sensor package includes an optical sight, FLIR, LRF, IFF, and a fire control computer. With these sensors, the Avenger can acquire and track targets in any battlefield environment, such as darkness, dust, smoke, or adverse weather.

The optical sight. The optical sight is a driven reticle heads-up display which allows the gunner to manually acquire targets through the canopy and to aim the missiles.

FLIR. FLIR provides enhanced acquisition capability in various environments: night, smoke, rain, background clutter, and haze. The automatic video tracker (AVT) is a subsystem of the FLIR. The AVT provides autotrack of the FLIR targets.

Laser range finder. The LRF is a self-contained, CO₂, eye-safe unit which provides accurate range information. The LRF is used to determine if the target is within the normal performance range of the missile. The LRF is more accurate and simpler for the gunner to use than MANPADS range ring profiles. It facilitates target engagements at maximum range.

IFF. The IFF distinguishes aircraft into three categories—positive friend, possible friend, and unknown. This aids the squad in the identification of targets. The IFF subsystem can provide the squad with up to four days of Mode 4 secure interrogations and several days of Mode 3 interrogations. It is essential that the interrogator be kept updated with Mode 4 data at least every four days.

Fire control computer. The fire control computer automates and simplifies several tasks required of the gunner during target engagement. These are superelevation, lead angle, shoot-on-the-move, and multiple engagements, as soon as one missile is activated. The system's automatic missile spin-up capability gives Avenger its ability to engage multiple targets.

Note: If the computer becomes inoperable, the section will convert to MANPADS.

Remote Control Unit. The gunner can operate the Avenger system remotely up to a distance of 50 meters using the RCU. The hand control switches and indicators on the RCU are the same as those on the gunner's console. However, adjustments to the FLIR console cannot be made from the RCU. As the environment or weather changes, it is critical that the FLIR be kept properly adjusted at all times so that the RCU remains effective.

The Simplified Handheld Terminal Unit

The SHTU displays track data and command and control information from the digital early warning net. The information is used for aerial target cues and WCS and ADW changes and acknowledgements.

An alert is defined as a warning signal of a real or possible danger such as an air attack. It is also a

forewarning or preparation for action.

A cue is specific and timely three-dimensional positional data with tentative identification within a designated fire unit's range (see Appendix K).

The light and special divisions interim sensor (LSDIS) and ground-based sensor (GBS) capabilities are an example of the difference between alerting and cueing. Both systems provide timely aerial target data, but only the GBS can provide the specific positional data for a cue. The LSDIS can only alert (see Appendix E). Avengers equipped with navigational and location devices input exact FU location into the SHTU for target displays relative to the FU.

LIMITATIONS

Avenger turrets without the environmental control unit (ECU) pose a heat hazard for gunners when required to operate inside the turret for long periods of time in extremely hot temperatures. In hot weather, units should use the RCU to permit the gunner to operate outside of the turret. In the future, all Avenger turrets will be equipped with an ECU that will allow the gunner to remain in the turret for long periods of time in hot and humid conditions.

Note: Gunners and observers must exchange positions frequently to

avoid heat injuries.

The Avenger fire unit is top-heavy. Exercise extreme caution when operating the system on steep grades and side slopes. The driver must observe driving restrictions on the vehicle instrument panel, and not drive on side slopes greater than 22 degrees.

The Avenger's size, weight, and height are important factors when

considering march routes or airlift for tactical vehicles. Planners, as well as vehicle drivers, must be aware of these physical characteristics. The Avenger weapon system is fielded on a light and heavy HMMWV. See both the Avenger (M998 and M1097) HMMWV Characteristics illustrations. For more information, see TM 9-1425-433-10.

AVENGER M998 HMMWV CHARACTERISTICS

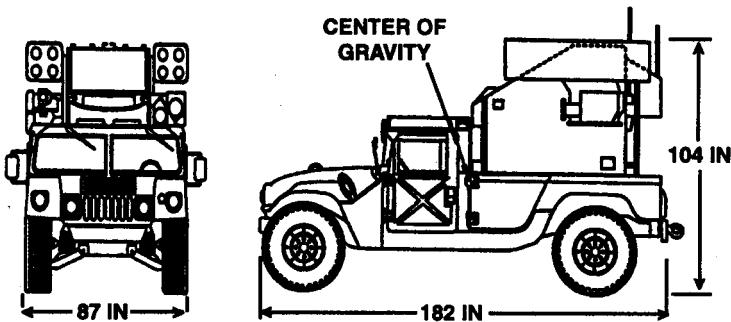

HEIGHT: 104 INCHES (2.66 METERS)

LENGTH: 182 INCHES (4.62 METERS)

WEIGHT: 8513 POUNDS (3861.41 KILOGRAMS)

WIDTH: 87 INCHES (2.21 METERS)

RANGE: 350 MILES (560 KILOMETERS)

SPEED: 55 MILES PER HOUR (88 KILOMETERS PER HOUR)

CONTINUOUS OPERATIONS: 24 HOURS

AVENGER M1097 HMMWV CHARACTERISTICS

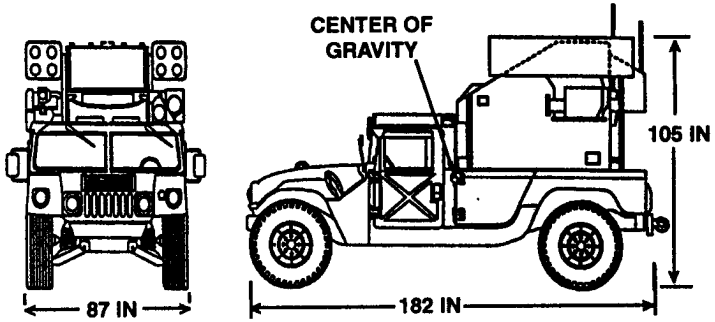

HEIGHT: 105 INCHES (2.66 METERS)

WIDTH: 87 INCHES (2.21 METERS)

LENGTH: 182 INCHES (4.62 METERS)

RANGE: 275 MILES (560 KILOMETERS)

WEIGHT: 8587 POUNDS (3894.98 KILOGRAMS)

SPEED: 55 MILES PER HOUR (88 KILOMETERS PER HOUR)

CONTINUOUS OPERATIONS: 24 HOURS

CHAPTER 2
**COMMAND, CONTROL, AND
COMMUNICATIONS**

This chapter discusses command and control techniques and communications requirements for the successful integration of the Avenger platoon with its supported force. Command is the authority vested in an individual of the armed forces for the direction, coordination, and control of military forces. Control is the authority, which may be less than full command, exercised by a commander over part of the activities of subordinate or other organizations. The platoon leader commands the Avenger platoon. The platoon sergeant assists the platoon leader in controlling the platoon. Effective platoon command and control is mainly dependent on leadership, training, standing operating procedures (SOPs), drills, and the effective use of control procedures and communications techniques.

COMMAND

For forces to properly task-organize to accomplish varying missions, command and support relationships have been established to define relationships

between supported and supporting forces on the battlefield. This section describes the relationships between supported and supporting units.

CONTENTS

	Page
Command	2-0
Control	2-15
Communications	2-26

COMMAND RELATIONSHIPS

Command relationships define the specifics of command, control, administration, and logistics between supported and supporting forces. Command responsibility and authority varies depending on the types of command relationships between units and elements. The four types of command relationships the Avenger platoon functions in are discussed in the following paragraphs.

Organic

A unit is organic when it forms an integral part of a larger unit and is listed in the larger unit's table of organization and equipment (TOE). For example, an Avenger platoon is organic to an Avenger battery.

Assigned

Assigned units are those units placed in an organization on a permanent basis. Assigned units are controlled and administered by the organization to which they are assigned. For example, an air defense artillery battalion is assigned to a division.

Attached

Attachment places a unit in an organization on a temporary basis. Attached units are subject to limitations specified in the attachment order. The attachment order should state clearly the administrative and

support responsibility of the gaining unit to the attached unit, and any limitations. The commander of the formation, unit, or organization receiving the attachment will exercise the same degree of command and control as he does over units organic to his command. When a unit is attached, the supported force normally provides administrative and logistical support to the attached unit. However, the responsibility for transfer and promotion of personnel will normally be retained by the parent formation, unit, or organization. For example, an Avenger platoon from one battery in the air defense battalion may become attached to another battery in the same battalion.

Operational Control

OPCON is a relationship in which a unit is provided to the commander of another unit to accomplish specific missions or tasks which are usually limited by function, time, or location. OPCON is normally assigned when the parent unit cannot exercise effective command and control. Units placed in an OPCON relationship do not normally receive administrative or logistical support, unless specified in the operation order directing their OPCON status. An example of OPCON is an Avenger platoon

placed under OPCON to a mechanized task force for an offensive mission.

SUPPORT RELATIONSHIPS

Support relationships define specific arrangements and responsibilities between supporting and supported units. There are four support relationships.

Direct Support

In direct support (DS), the supporting unit provides dedicated support to a specific unit. A DS ADA unit provides dedicated air defense for a specific element of the force which has no organic air defense. The supporting ADA unit coordinates its movement and positioning with the supported unit. An Avenger platoon, for example, may provide direct support to a task force. The platoon will provide dedicated support to the task force, and the platoon leader will position the platoon in conjunction with the task force commander's concept of the operation.

General Support

An ADA unit in general support (GS) provides support for the force as a whole. It is not committed to any specific element of the supported force. It does not support a specific unit within the larger unit's area of operations. An ADA unit in general support remains under the control of its

higher ADA commander and is positioned by its ADA commander.

Reinforcing

A reinforcing (R) ADA unit augments the support of another ADA unit or strengthens the air defense of the force. A reinforcing ADA unit is positioned to protect one or more of the reinforced unit's priorities as specified by the supported ADA unit commander. For example, an Avenger platoon could reinforce the ADA battery of a separate heavy brigade attached to the division.

General Support-Reinforcing

An ADA unit with a general support-reinforcing (GS-R) mission provides support for the force as a whole and augments the support provided by another ADA unit. ADA units with a GS-R mission still have a responsibility to provide support to units or assets within a specific area, but they must coordinate with the supported ADA unit to reinforce the coverage of assets in the area of operations.

SELECTING A SUPPORT RELATIONSHIP

The ADA Support Relationships illustration shows responsibilities associated with each ADA relationship. To determine the most appropriate support relationship for accomplishing the ADA mission, the questions in the illustration need to be answered.

ADA SUPPORT RELATIONSHIPS

	DIRECT SUPPORT	GENERAL SUPPORT	REINFORCING	GENERAL SUPPORT-REINFORCING
Who establishes ADA priorities?	The supported commander.	The ADA commander assigning the support relationship, based on the supported commander's priorities.	The supported commander through the reinforced ADA commander.	(1) The supported commander. (2) The supported commander through the reinforced ADA commander.
Who positions ADA fire units?	ADA fire unit commanders with approval of the local ground commander.	ADA fire unit commanders in coordination with the local ground commander.	ADA fire unit commanders with approval of the reinforced ADA commander and local ground commander.	The ADA fire unit commanders in coordination with the local ground commander and reinforced ADA commander.
Who coordinates terrain on which ADA units will position fire units?	The DS ADA commander (approved by the supported commander).	The commander assigning the support relationship.	The reinforced ADA commander with the supported commander.	The commander assigning the mission with the supported commander and reinforced ADA commander.
With whom should liaison be established?	Supported unit.	Supported unit.	With supported unit including reinforced ADA commander.	With supported unit including reinforced ADA commander.
With whom should communications be established?	Supported unit.	Supported unit.	With supported unit including reinforced ADA commander.	With supported unit including reinforced ADA commander.

Notes:

1. The term "position(s)" specifies the selection of the exact placement of individual fire units within the operating area.
2. A unit supporting another unit is responsible for establishing communications with the supported unit.

STAFF COORDINATION

It is imperative that the platoon leader coordinate with the supported unit's staff throughout the planning process. Examples of information coordinated with the supported task force are listed below in the following text and in the Supported Force and ADA Platoon Leader Responsibilities illustration on the next page.

COMMANDER

The platoon leader provides the commander with the status of his air defense combat power. The platoon leader must understand the commander's intent, the amount of risk he is willing to accept, and his guidance. The commander will determine his priorities based on the platoon leader's recommendation. The commander is the final approval authority for the ADA plan.

S1 Section

The platoon leader will give the S1 a battle roster of authorized and on-hand personnel by military occupational specialty (MOS) and grade. He must also coordinate to integrate platoon casualty evacuation into the TF plan. Routine personnel reports required by the supported unit, such as personnel status reports, must be submitted as specified in the supported unit's tactical SOP (TSOP).

S2 Section

The platoon leader assists the supported unit's S2 in the development of the air intelligence preparation of the battlefield (IPB). The platoon leader must pay particular attention to enemy air avenues that can influence the supported force's area of operations. Enemy air avenues and corresponding air named areas of interest (NAIs) must be depicted on the supported unit's intelligence overlay. Time permitting, the battery commander should provide this information to the platoon leader.

S3 Section

The platoon leader recommends AD priorities to the supported commander and helps the S3 integrate air defense into the supported unit's operations. During the planning process, the platoon leader will assist in developing any graphics dealing with his platoon's scheme of maneuver. The platoon leader will receive a copy of the supported force's final operational graphics with the OPOD. He should also request an update of enemy activity, security, and possible minefield in the area. These graphics must be disseminated to the platoon sergeant and section leaders.

**SUPPORTED FORCE AND ADA
PLATOON LEADER RESPONSIBILITIES**

STAFF AGENCY	SUPPORTED FORCE DETERMINES—	ADA PLATOON LEADER ASSISTS AND COORDINATES WITH—
S1	Casualty evacuation plan	Providing battle roster Integrating into evacuation plan
S2	Ground operations Enemy regiments main objective Enemy follow-on forces Enemy artillery locations Avenues of approach	Input to air IPB Input on enemy air capabilities, operations, and objectives
S3	Intent Scheme of maneuver Terrain management Army aviation plan TOC/TAC LOC/operations Mission changes Dissemination of EW TF/TM graphics Combined arms AD operations ADA priorities approval Passive air defense	ID priorities over time A²C² plan Other ADA units Redundant EW plan ADA execution matrix Command/support relationship ADA force allocation ADA movement plan Synchronization of ADA with supported force scheme of maneuver Advice to commander on passive AD
S4	Combat/field train LOC MSRs/movement priorities LOGPAC/plan Availability of resources	ADA logistical plan Recovery ADA peculiar items
ENGR	Obstacle plan Routes Survivability priorities	Survivability Mobility Obstacle plan
FSO	Fire support plan/ FASCAM	Attack on enemy FAAs/FACS FA call for fire/TRPs Input to fire support plan
ALO		Type of aircraft IFF codes Frequencies Area of operations Time of operations
NBCO	MOPP level Decontamination sites Contaminated areas Downwind messages	
CESO	Frequencies/call signs Radio maintenance plan Sensor connection	

S4 Section

While the platoon sergeant executes logistics for the platoon, the platoon leader must conduct initial coordination with the supported force. The PSG will conduct additional coordination with the supported force's S4 or support platoon leader, as well as the ADA battery first sergeant. The platoon sergeant may contact the supported force on its ADMIN/LOG radio net to conduct routine logistics functions and submit reports required by the supported force SOPs. More information on logistics is contained in Chapter 6.

Engineer

Once the supported unit's obstacle plan and engineer priorities for support have been specified, the Avenger platoon leader will coordinate with the supported force engineer. If the Avenger platoon is scheduled to receive engineer support for the mission, direct coordination with the supported force engineer is required to coordinate specific vehicle location requirements.

Fire Support Officer

The platoon leader's coordination with the fire support officer (FSO) may include the following: type and location of targets and target reference points (TRPs), A²C² information, and current fire support information. Full integration with the fire support scheme

of maneuver is imperative for mission accomplishment.

Air Liaison Officer

The air liaison officer (ALO) is a critical staff member to coordinate with. The ALO can assist in the air portion of the IPB process by giving a pilot's perspective to possible air avenues of approach (AAAs). He is also key to A²C² synchronization. The ADO can reduce the risk of fratricide by coordinating with the ALO concerning the friendly air and ADA plan.

Nuclear, Biological, and Chemical Officer

The platoon leader must include decontamination sites, MOPP level, and emergency procedures for downwind message in his platoon briefing. The platoon sergeant must ensure that each squad member has the necessary equipment to accomplish the mission.

Communications-Electronics Staff Officer

The platoon leader coordinates with the communications-electronics staff officer to ensure his platoon is given the current frequency and call signs. This further ensures that resupply, maintenance, and communications can be maintained at all times.

COMBAT ORDERS

Combat orders are the tools with which leaders and staffs

transmit battle plans to subordinate units. The Army has developed standard combat order formats; however, units often modify or augment basic combat order formats to meet their specific needs.

Combat arms platoon leaders may issue orders either verbally or in writing, depending on time available. Optimally, combat orders should reference unit SOPs to enhance brevity and clarity.

Avenger platoons will use a combination of combat order formats. In addition to the orders format used by the parent air defense artillery battery, the platoon leader must use the supported unit's orders format. This section will list the most frequently used combat orders and describe the basic information included in each.

Warning Order

A warning order (WARNO) notifies subordinate units of future missions. Normally, warning orders include the anticipated upcoming mission statement, any changes to task organization, any movement instructions to position units for the upcoming mission, a general description of the area of operations, an intelligence update, and time and location for issue of the operation order. The WARNO should be brief. It may be disseminated via radio or messenger. A sample WARNO is in Appendix A.

Operation Order

An operation order (OPORD) is a complete order issued to units prior to a specific mission or a series of missions and follows the format topics listed below:

- Situation.
- Mission.
- Execution.
- Service Support.
- Command and Signal.

OPORD formats are frequently modified by units to meet their specific needs while adhering to the standard five-paragraph format. OPORDs may contain annexes for each paragraph to more completely describe the actions and events.

Avenger platoon leaders will write the air defense annex to the supported unit's OPORD. Depending on the parent air defense artillery battery and supported unit SOPs, the air defense annex may be written fully or in matrix format. An example of an air defense annex is in Appendix A.

Fragmentary Order

A fragmentary order (FRAGO) is an abbreviated form of an OPORD. A FRAGO is used to update existing OPORDs. Examples of information contained in FRAGOs are changes in enemy situation, friendly task organization, mission, graphic control measures, commander's intent, and scheme of maneuver. During extended operations, units will publish an initial OPORD and update it with

FRAGOs for each follow-on mission. Like warning orders, FRAGOs are usually brief oral or written messages. An example of a FRAGO is in Appendix A.

TROOP-LEADING PROCEDURES

Upon receipt of an order, combat arms platoon leaders must begin their own planning process. Troop-leading procedures are designed to focus the leader's effort, given the time available, on preparations for the ensuing mission.

Avenger platoon leaders must understand the steps of troop-leading procedures and practice them to implement them efficiently for each mission. This section addresses standard troop-leading procedures and how each step applies to the Avenger platoon leader.

Step One Receive the Mission

Upon receipt of the mission, the platoon leader must conduct an initial mission analysis as well as begin to prepare the platoon for its next mission. The ADA mission as well as the task force mission must be considered. Timely mission analysis for both air defense and supported force requirements will enhance the efficiency of the planning process.

Depending on the command and support relationship, the Avenger platoon leader may or may not receive an AD plan from his battery commander. If he does, this

plan may be given by the battery commander via various means (radio, facsimile [FAX], et cetera) due to battery dispersion and time available. This plan may be general, depending on information available. The AD plan will normally include the air defense artillery task organization, current situation, battery mission, supported unit commander's intent, and scheme of maneuver for the supported unit.

The AD plan will continue to be adjusted based on the maneuver plan. Each task force will receive the brigade order containing the completed AD annex. The Avenger platoon leader supporting the task force must review the AD annex in the brigade OPORD. This written annex contains the AD plan that will provide the Avenger platoon leader information on the following:

- Ground and air intelligence preparation of the battlefield (IPB).
- The sensor plan.
- Enemy aviation C² facilities targeted by the division.
- Locations where the platoons may be employed.
- The Army airspace command and control (A²C) plan.
- The logistics plan.

The platoon leader should have sufficient information from the battery AD plan to synchronize his air defense plan with the supported unit scheme of maneuver. Accordingly, he must consider the following: mission; commander's

intent; and reconnaissance, intelligence, surveillance, and target acquisition (RISTA) threat.

Leaders must follow a logical process when analyzing the mission requirements. The commander's estimate of the situation includes an analysis of mission, enemy, terrain, troops, and time available (METT-T). The platoon must be aware of the factors of METT-T and how they apply at platoon level. METT-T must be applied during mission analysis for both air defense requirements and the ground scheme of maneuver. Following are examples of questions that may be considered during mission analysis:

- What is the mission? What are the specified and implied tasks? What is the commander's intent? If the Avenger platoon is DS to a task force, the Avenger platoon leader must conduct mission analysis for both the AD mission and the supported task force mission.

- Where is the enemy, and what is his strength? What is the enemy air threat? What weapons does he have that can affect the supported force? What can he do in response to the platoon's actions? What are his weaknesses and how can the platoon exploit them? The Avenger platoon leader must consider the ground threat as well as the enemy air threat.

- What is the impact of terrain and weather on both air and ground operation? Observation

and fields of fire, cover and concealment, obstacles, key terrain, and avenues of approach (OCOKA) should also be considered.

- What are the conditions of personnel and vehicles? What is the status of ammunition, fuel, and supplies? Who is best able to do a specific task? What is the crew endurance (rest) plan? What other assets are available to support the mission? What are the other ADA platoons in the supported force doing? Who and where are the adjacent ADA units?

- How much time is available for planning and mission preparation prior to mission execution? How long will it take to position assets and prepare positions if necessary? When can the platoon rehearse? The platoon leader should adhere to the 1/3-2/3 planning rule and take no more than 1/3 of the time allocated to prepare his order and disseminate the order to his platoon.

Step Two- Issue a Warning Order

The platoon leader issues a warning order to the platoon upon receipt of a warning order from higher headquarters. The WARNO is refined upon receipt of the OPORD or FRAGO. The platoon leader briefs the platoon on the upcoming mission, initial preparations that must be made, when and where a detailed OPORD will be issued, and any other information that he can give the platoon to aid in its preparations.

Step Three-

Make a Tentative Plan

The platoon leader begins planning by reviewing the information gleaned during mission analysis. Backward planning, based on the analysis of available time, must be conducted. The result of backward planning will result in a time line that may include the following events:

- Mission execution time (line of departure or defend no later than time).
- OPORD issue time.
- Movement time between positions.
- Emplacement time.

The initial time line must be disseminated to the platoon as soon as possible and be updated as necessary.

Once the time line is complete, the platoon leader will begin to plan his concept for air defense coverage, based on higher headquarters plans. At the same time, he will begin to plan his platoon's ground scheme of maneuver, based on the supported force's ground scheme of maneuver. To begin planning, the platoon leader must have an understanding of enemy air and ground avenues of approach, the supported force mission and scheme of maneuver, and the supported force commander's intent.

The Avenger platoon leader will conduct parallel planning with the supported unit's staff. This occurs during the staff planning process. The Avenger platoon leader, as the senior air defender of the supported force,

is the commander of the Avenger platoon, supported force commander's air defense advisor, as well as the staff air defense officer. Integration with the supported force staff during the planning process and an understanding of the planning process used by the supported force are imperative for proper mission planning. The Avenger platoon leader must align his air defense plan and his plan for positioning his fire units with the phases specified in the supported force's scheme of maneuver.

During the planning process, the platoon leader must ensure that any additions or changes to mission-specific information are immediately disseminated to the platoon (that is, linkup time and location with subordinate units, current task force and company team locations, changes to task organization, et cetera).

When developing the plan for air defense coverage of any supported force, the platoon leader must consider the six air defense artillery employment guidelines. These guidelines aid air defenders at all levels when planning for air defense coverage.

Early engagement Fire units must be positioned so they are capable of engaging enemy air platforms before they can release their ordnance or gain intelligence about friendly forces. With the mobility provided by the Avenger, units may be located well

forward to support the scheme of maneuver of the supported force.

Weighted coverage. Once the supported force commander designates his main effort, Avenger fire units should be positioned along the most likely enemy air avenues of approach to support the commander's main effort. This massing of firepower increases the Avenger platoon's probability of destroying enemy air targets. It is extremely important that a detailed, in-depth air IPB be developed prior to deciding where to provide weighted coverage of air defense assets.

Depth. Depth is achieved by positioning fire units so threat air platforms encounter an ever-increasing volume of fire as they approach the protected force or asset. The Avenger platoon leader achieves depth by positioning his assets so that they can provide continuous fires along enemy air avenues, destroying the enemy as it advances toward the protected force or asset. Depth is maximized through the integration of all air defense weapons used in the defense. Additional air defense assets on the battlefield such as MANPADS, BSFV fire units, HIMAD assets, and combined arms air defense efforts from ground forces contribute to the creation of depth on the battlefield.

Balanced fires. Balanced fires are created by positioning air defense weapons to distribute fires equally in all directions. Except for the mission of defense of a static asset, where no

clear avenues of approach are identified, this guideline will seldom be employed. As an example, on a flat, open battlefield characteristic of a desert environment, no specific air corridors exist. In this scenario, planning for balanced fires may be viable.

Mutual Support. Mutual support is achieved by positioning weapons to complement fires from adjacent fire units, thus preventing the enemy from attacking one position without being subjected to fire from one or more adjacent positions. Mutual support will enhance volume of fire as well as cover dead space of adjacent units. The planning range for mutual support for Avenger systems is approximately 3,000 meters.

Overlapping fires. Fire units should be positioned so that engagement envelopes overlap. When terrain limitations exist or the size of the area to be covered is limited, or there is a scarcity of available Avenger systems, the air defense planner should attempt to enhance the AD protection of the force or asset by ensuring engagement envelopes overlap. The planning range for overlapping fires for Avenger systems is approximately 4,000 meters.

In developing the plan, the Avenger platoon leader will incorporate a mix of guidelines in his coverage plan according to the mission, availability, limitations, survivability of ADA assets, the tactical situation, and the threat. Integrating all plan guidelines will

seldom be possible or desirable. The most important guidelines for the Avenger platoon leader to consider include early engagement, weighted coverage, and depth.

Planning guidelines for developing the platoon's ground scheme of maneuver will incorporate those topics considered in developing the air defense coverage plan. The platoon leader will consider METT-T and OCOKA in development of his plan.

The platoon leader will determine best positions for both himself and the platoon sergeant based on the following:

- Platoon task organization.
- Location of the supported force command post.
- Platoon dispersion.
- Routes between locations.
- Survivability of locations.
- Communications with air defense network.

Initial positions for individual Avengers will be determined by considering—

- Maximum observation and fields of fire on high ground over probable air avenues of approach.
- Depth.
- Communications with platoon leader, platoon sergeant, adjacent sections, squads, and sensors.
- Routes to and from positions.
- Protection against ground attack.

Platoon leaders must coordinate fire unit positions with the

supported force. Sensors may be attached to the battery. If so, the battery commanders may have the sensor supported by a nearby AD weapon. Sensor positions will be selected by the AD S3 and the maneuver brigade S3 according to the IPB process which dictates those NAls, TAls, and AAAs.

Step Four— Initiate Necessary Movement

Movement should begin as soon as possible following warning order receipt. Often, movement occurs simultaneously with initiating the planning process. Normally, the platoon leader reports to the supported force tactical operations center (TOC) and begins the planning process with the staff. The platoon sergeant conducts resupply operations for the platoon and the initial coordination for linkup with the supported force. The platoon should be positioned to facilitate support of the upcoming mission.

Step Five— Conduct Reconnaissance

If possible, a ground reconnaissance of the area in which the supported force will fight must be made. This is often possible for defensive operations but harder to accomplish for offensive operations. Reconnaissance of the ground on which the platoon will fight will confirm or deny the tentative plan. For the Avenger platoon leader in

support of a maneuver task force, reconnaissance efforts will normally be completed in conjunction with the task force reconnaissance. As a minimum, a map reconnaissance of the area in which the supported force will fight must be made.

Step Six— Complete the Plan

Based on the reconnaissance, the plan will be adjusted, details will be added, the air defense annex to the supported force OPORD will be completed, and the platoon OPORD will be finalized.

Step Seven— Issue the Operation Order

Orders may be issued verbally or in writing. When issuing orders, leaders must ensure that each soldier knows how to accomplish the mission and how they fit into the plan. Leaders should provide the platoon leader with a backbrief to ensure section leaders fully understand the mission and their required tasks. Orientation on terrain should be included, if possible. Sand tables and terrain models are effective tools to use if time is available for their construction.

Step Eight— Rehearse, Execute, and Supervise

Rehearsals should be conducted prior to each mission. They can be conducted on the ground, over the radio, or on sand tables or terrain

boards. Time permitting, all personnel in the platoon should attend the rehearsals; often, only the platoon leader, platoon sergeant, and section leaders will attend platoon rehearsals. The platoon's execution matrix is the script for the rehearsals. The platoon must leave the rehearsal with a clear understanding of its mission and where it fits into the supported force scheme of maneuver.

The Avenger platoon leader is an important participant at supported force rehearsals. He will explain the air defense plan to support the scheme of maneuver for each phase of the operation and describe its integration into the supported force scheme of maneuver. Final coordination with the supported force staff may occur at the rehearsal. ADA integration in the planning, preparation, and execution phases of the mission is critical. Usually, integration will occur concurrently at respective levels within the supported force. See the ADA Concurrent Planning Process illustration.

Execution and supervision will fall into place if a solid plan has been developed. The platoon leader must ensure vehicles are in correct positions, radio nets are monitored, and the platoon is ready to execute according to its matrix. Experience will enable the platoon leader to make decisions during execution based on changing enemy actions and modifications to the supported force scheme of maneuver.

ADA CONCURRENT PLANNING PROCESS

BRIGADE	ADA	SUPPORTED FORCE	ADA PLATOON
New mission WARNO	WARNO	WARNO	WARNO
Staff estimate	Gather information Recommend COA Allocate ADA	Move Prepare for future operations Begin planning process Leader recon -Intent -TASKO	Linkup with SF
Decide on COA	Issue DST/DSN to platoon		Conduct planning with supported force -Aerial IPB -Supported force mission -Supported force scheme of maneuver
Rehearse	Rehearse with brigade	Staff estimates SF COA decision OPORD brief SF rehearsal	-Supported force commander's intent -AD concept -A ² C ² information -Concept for logistics support -Recommend AD priorities -Complete AD annex Brief OPORD/AD annex Brief OPORD to platoon Rehearse with task force Update execution matrix Conduct platoon rehearsal Execute DSM
	Refine DST Execute DSM		Executes TF execution matrix

CONTROL

Combat units at all levels are controlled on the battlefield through two major control methods: positive and procedural. This section will discuss the various types of positive and procedural control measures the Avenger platoon uses to accomplish its mission.

POSITIVE CONTROL MEASURES

Positive control measures are developed through use of existing equipment and systems. Air defense positive control measures include early warning, alerting and cueing by sensors, and directed early warning.

Early Warning Sensors (Alerting and Cueing)

Early warning sensors are an air defense unit's primary resource for locating aerial targets. Early warning sensors are employed to observe aerial NAIs, TAIs, and air avenues of approach. The sensors broadcast air track data information on the EW net.

Early warning gives the initiative to the air defender. Accurate and timely early warning allows the Avenger to maximize the weapon system engagement capability against the aerial threat and also assists the maneuver commander in protecting his forces. There are numerous methods used to pass early warning information. Early warning dissemination requires careful coordination to ensure that the

information gets to those who need it, at the proper place and time, and in the proper terminology. The Avenger platoon leader must ensure that all applicable early warning is passed to the supported force. See the Early Warning Network (A Backup to EW) illustration. For additional information, see Appendix E.

Directed Early Warning

Directed early warning (DEW) is designed to alert a specific unit or area of the battlefield of an immediate aerial threat. It is passed over the supported unit command net or a net designated by the supported unit commander. DEW defines the local air defense warning and states whether the aerial platform is unknown or friendly, location of the aerial platform, provides a cardinal direction of approach for the aerial platform, and, if unknown, the element most likely affected within the force.

DEW is quick, simple, redundant in nature, and is given in clear text. The unit SOP will specify the exact procedures to be used. The following elements of DEW will be determined by unit SOP:

- Preface.
- Identification
- Local air defense warning.
- Direction.
- Size.
- Affected asset.

EARLY WARNING NETWORK (A BACKUP TO EW)

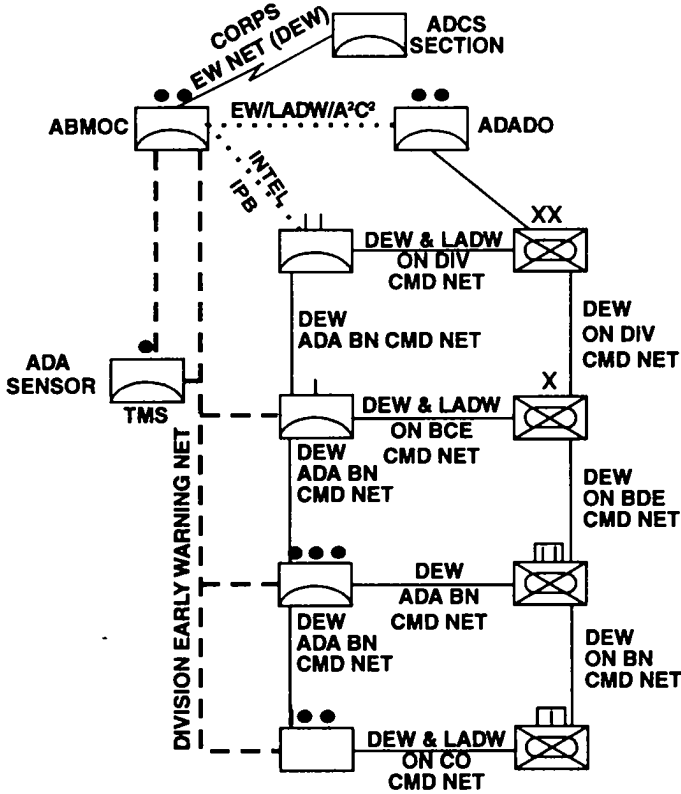

Legend:

- DIRECTED EARLY WARNING (ALERT, NUMBER OF A/C, DIRECTION, AND GENERAL LOCATION)
- - - - - EARLY WARNINGS INTERFACES
- OTHER NETS AND INTERFACES
- TA312, MSE, OR DIV CMD NET

Notes:

1. ABMOC generally located with BN HQ/TOC.
2. ADADO located with DIV main.
3. ADA units may also monitor sensor net.
4. ADA CMD net may be used as alternative EW nets.

PROCEDURAL CONTROL MEASURES

Procedural control measures are control measures developed through established rules and standing operating procedures. Procedural control relies upon techniques such as segmenting airspace by volume and time, and using a weapon control status (WCS). Procedural techniques are usually more restrictive than positive techniques but are less vulnerable to degradation from electronic or physical attack.

Air Defense Warnings

Air defense warnings (ADWs) are established by the corps or area air defense commander. Any commander may raise the ADW. When received, ADWs apply to the entire force or a specific area and must be disseminated to every soldier within the force. At the brigade level and below, air defense warnings are disseminated over redundant nets along with LADWs. ADA commanders do not change readiness posture by changing ADW, but instead by raising or lowering a state of readiness (SOR). See the following illustration and the SOR Examples illustration.

AIR DEFENSE WARNING

ADW Red—Attack or surveillance by hostile aerial targets or missiles is imminent or in progress. This means that hostile aerial targets or missiles

are within a respective area of operations or in the immediate vicinity of a respective area of operation with high probability of entry.

ADW Yellow—Attack or surveillance by hostile aerial targets or missiles is probable. This means that hostile aerial targets or missiles are en route toward a respective area of operations, or unknown aerial targets or missiles suspected to be hostile are en route towards, or are within, a respective area of operations.

ADW White—Attack or surveillance by hostile aerial targets or missiles is improbable.

Local Air Defense Warnings

Local air defense warnings (LADWs) are designed to alert a particular unit, several units, or an area of the battlefield. LADWs parallel standard air defense warnings and reflect the local aerial threat. They should be incorporated into SOPS which explain what response is desired by the supported force. For example, when Dynamite precedes ADW Red, the affected force may stop to increase passive air defense and engage with a combined arms response. The response desired by the force is METT-T dependent. See the Local Air Defense Warnings illustration.

**LOCAL AIR DEFENSE
WARNINGS**

Snowman-No threatening aerial targets are in the area.

Lookout-Aerial targets may be in the areas of interest but are not threatening, or are inbound, but there is time to reset.

Dynamite-Aerial targets are inbound or are attacking locally now. Response is immediate.

States of Readiness

States of readiness (SOR) describe the degree of readiness of ADA fire units. The decision to select SOR is based on intelligence, EW, and air defense warnings. SOR are normally designated by ADA battalion or battery commanders for their subordinate platoons and or fire units. Additionally, SOR are used to ready the force in a logical way for action against the enemy while retaining the ability to stand down units for rest or maintenance. See the SOR Examples illustration which is based on sample states of readiness.

SOR EXAMPLES

ADW	LADW Dynamite	LADW Lookout	LADW Snowman
Red	SOR 1	SOR 1	SOR 2 or >
Yellow	SOR 1	SOR 2 or >	SOR 3 or >
White	SOR 1	SOR 2 or >	SOR 3

- SOR 1—An FU is capable of completing its target engagement drill within the drill standard.
- SOR 2—An FU is capable of beginning its target engagement drill within 5 minutes.
- SOR 3—An FU is capable of beginning its target engagement drill within 30 minutes.
- SOR 4—An FU is moving or released from its mission.
- SOR 5—An FU is NMC.

Fire Control Orders

Fire control orders are commands used to control engagements on an individual basis regardless of the prevailing WCS. For the Avenger platoon, fire control orders are normally issued by the immediate ADA commander (section leader and squad leaders). The leader initiates orders for fire control purposes and for ensuring safety. Fire control orders are—

- Cease Fire—Gunner does not fire—continues to track.
- Hold Fire—Gunner ceases all tactical action, to include tracking (resume search of assigned sector).
- Engage—Gunner fires.
- Cease Engagement—Gunner changes an ongoing engagement from one target to another of higher priority. This order accompanies direction-to engage new target.

Rules of Engagement

Rules of engagement (ROE) are used to control fires to protect friendly forces and to maintain the needed level of defense. The ROE tells the Avenger section what, when, and where they may shoot. There are three primary ROE which are applicable to the Avenger.

Right of self-defense. The right of self-defense is never denied. The ADA section always has the right to defend itself or its supported unit.

Hostile criteria. ADA squad leaders have both identification and

engagement authority. The exact criteria enabling the fire unit to declare a target hostile may vary with the tactical situation. Hostile criteria may include—

- Attacking friendly elements.
- Violating airspace control measures.
- Being visually identified as hostile.
- Responding improperly or not at all to IFF interrogation.

The Avenger squad leader has engagement authority. The target must satisfy one or more of the theater hostile criteria.

Weapon control status. WCS describes the degree of control for air defense fires. WCS applies to weapon systems, volumes of airspace, and types of aerial threats. The degree or extent of control varies depending on the tactical situation. The corps commander usually has WCS authority for rotary-wing aerial threats. ADA forces must have the ability to receive and disseminate WCSs: The WCSs are—

- WEAPONS FREE—Fire at any aerial threat not positively identified as friendly. This is the least restrictive status.
- WEAPONS TIGHT—Fire only at aerial threats positively identified as hostile.
- WEAPONS HOLD—Do not fire except in self-defense. The term self-defense includes defense of the fire unit, supported unit, and protected asset. This is the most restrictive status.

Autonomous Operations

Autonomous operations are implemented when communications with the battery or higher controlling headquarters are lost for any reason. The platoon or squad leader must take immediate action to reestablish communications. Specific actions will be listed in the battery SOP. If communications are lost, the WCS will remain the same. If a time limit is placed on the weapon control status, the fire unit will maintain that status until this time limit expires and then revert to WEAPONS TIGHT. If the fire unit is in a WEAPONS HOLD status and a time limit was not established, it will maintain that status for 30 minutes and then revert to WEAPONS TIGHT. If the fire unit is using

WEAPONS FREE and a time limit was established, the same rule applies as in WEAPONS HOLD. If no time limit was established for a fire unit using WEAPONS FREE, it will immediately revert to WEAPONS TIGHT. See the Weapon Control Status During Autonomous Operations illustration.

AIR AND GROUND FIRE CONTROL MEASURES

The differences in Avenger and gun turret weapon systems and their engagement techniques require separate control measures for each weapon system. For aerial targets, an ADA fire unit is assigned a sector of fire (SOF) and a primary target line (PTL). These are designated by the

**WEAPON CONTROL STATUS DURING
AUTONOMOUS OPERATIONS**

If WCS is...	and communications are lost and WCS has a time limit...	and communications are lost and WCS has no time limit...
WEAPONS FREE	remain at WEAPONS FREE for duration of time limit, then revert to WEAPONS TIGHT	Immediately revert to WEAPONS TIGHT
WEAPONS TIGHT	remain at WEAPONS TIGHT	remain at WEAPONS TIGHT
WEAPONS HOLD	remain at WEAPONS HOLD for duration of time limit, then revert to WEAPONS TIGHT	remain at WEAPONS HOLD for 30 minutes, then revert to WEAPONS TIGHT

platoon leader after a review of fire unit positions to ensure that all aerial targets threatening the protected asset can be engaged. These measures assist in the distribution of air defense fires against multiple targets threatening from different directions. Each fire unit concentrates its fires on the most threatening aerial target within its assigned sector or closest to its PTL. Controls provide efficient fires and reduce the probability of simultaneous engagements from two or more systems.

Avenger Control Measures

The platoon leader controls his FUs by establishing control measures. These control measures assist in the distribution of Avenger fires. This is one of the most important tasks the platoon leader will have to decide.

Primary target line. A PTL is an azimuth along which the gunner will focus his attention.

Sectors of fire. SOFs are specified by left and right limits SOFs aid target detection and identification of aerial targets. The fire unit will focus its attention (both searching and firing) within the designated sector. See the Sector of Fire and PTL illustration.

Selection Criteria

The assignment of an SOF and PTL does not restrict the Avenger squad to look only in that sector. Given two targets of equal capability

within the sector of fire, the target closest in range to the PTL will be engaged first. Platoon leaders will ensure assignment of PTLs and SOF for each system during the planning of the operation. See the Single and Multiple Targets Selection Criteria illustration on page 2-22.

SECTOR OF FIRE AND PTL

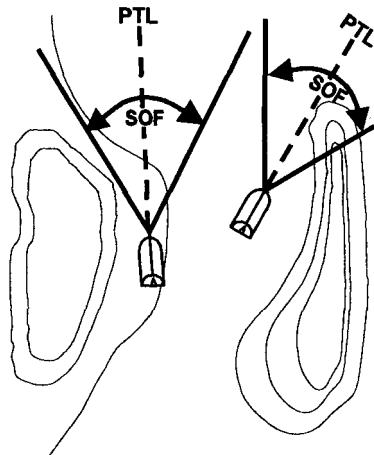

SINGLE AND MULTIPLE TARGETS SELECTION CRITERIA

WHEN DO YOU ENGAGE?

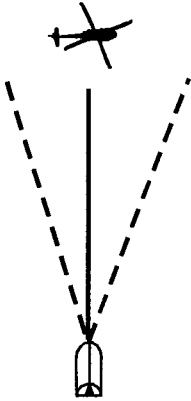

Always engage as soon as possible.

CROSSING RW EAST TO WEST. WHICH FU ENGAGES?

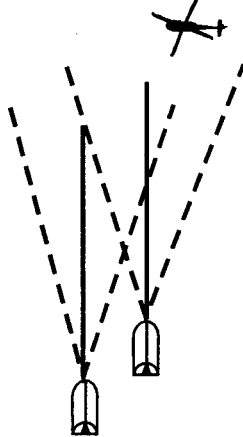

FU on the right engages.

INCOMING RW. WHICH FU ENGAGES?

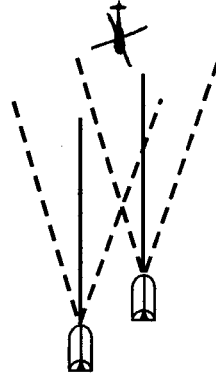

FU first to acquire engages. FUs must communicate. If in doubt and ready, shoot.

MULTIPLE RW. WHICH FU ENGAGES WHICH RW?

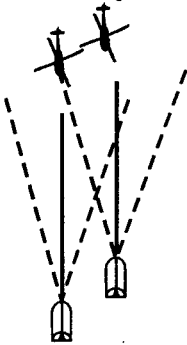

Left FU engages left RW. Right FU engages right RW. If RW in trail, left FU shoots lead RW, and right FU shoots RW in trail.

MULTIPLE FIXED- AND ROTARY-WING AC. WHICH FU ENGAGES WHICH AC?

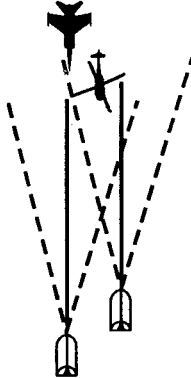

FW has priority over RW. Left FU engages left AC. FUs must communicate.

MULTIPLE RW IN ONLY ONE FU SECTOR. HOW DO YOU ENGAGE?

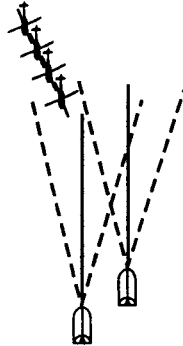

Left FU engages as many RW as possible. Coordinates with right FU to tell it when and what target to shoot.

ADDITIONAL CONTROL MEASURES

The platoon leader will use several control measures which are the rules and mechanisms promulgated by joint and allied doctrine, and defined by the theater airspace control plan. They are associated with communications and airspace. They are described in the following paragraphs.

Emission Control Measures

Emission control (EMCON) measures apply to the radios within the Avenger platoon. Emission levels and conditions are listed in the OPOD. When operating with a maneuver force, the local commander may dictate some emission control measures such as radio silence or "EMCON silent." Emission control measures may also be listed in the battery or maneuver unit SOP.

Airspace Control Measures

Airspace control measures afford the commander a variety of procedural methods to increase combat effectiveness by promoting the safe, efficient, and flexible use of airspace. Airspace control measures are rules and mechanisms put into effect by multiservice perspective doctrine. This doctrine defines how the Army and Air Force execute the airspace functions in Army-Air Force operations, and methods the Marine Corps and Navy employ to

provide airspace control in amphibious operations.

Joint Army, Marine Corps, Navy, and special purpose procedural airspace control measures include—

- High-density airspace control zone (HIDACZ). The ground commander may establish a HIDACZ with approval of the ACA. This HIDACZ area allows the ground commander to control the use of a particular volume of airspace and establish WCS within that area. Example of use would be to allow a division commander to execute a joint air attack team (JAAT) mission.

- Standard use Army aircraft flight route (SAAFR). The SAAFRs are jointly recognized but do not need ACA approval. These are routes established below the coordinating altitude to allow the Army commander to safely route movement of his aviation assets performing CS and CSS missions. They are normally located in corps through brigade rear areas but may be extended to support logistics missions.

- Minimum risk route (MRR). MRRs are temporary corridors of defined dimensions recommended for use by high-speed, fixed-wing aircraft that present minimum known hazards to low-flying aircraft transiting the theater airspace.

- Restricted operations area and restricted operations zone (ROA and ROZ). ROA and ROZ are synonymous terms for defining a volume of airspace set aside for a specific operational mission or requirement.

- Coordinating altitude. This is a procedural method to separate fixed- and rotary-wing aircraft by determined operating altitudes for each type of aircraft.

The Army aviation operations rely on freedom of movement to and from the forward area and lean heavily toward procedural versus positive control. Distinctive Avenger platoon measures are defined as previously described. They include the-

- Battle position (BP). A BP is a defensive location oriented on the most likely enemy avenue of approach from which a unit may defend or attack.

- Initial point and release point (IP/RP). An IP and RP are predetermined points on the ground used to initiate a control procedure (IP) or terminate the conduct of a control procedure (RP).

- Air control point and aerial checkpoint. An ACP or aerial checkpoint is a predetermined point on the ground used as a means of coordinating or controlling friendly Army aircraft movement.

- Air corridor. An air corridor is a restricted air route of travel specified for use by friendly Army aircraft and established to prevent fratricide on friendly aircraft from friendly forces.

- Air axis. An air axis is similar to a ground axis of advance and is

assigned for control, which graphically depicts a commander's intentions.

- Engagement area or kill zone.

An engagement area or kill zone is an area in which the commander intends to trap and destroy an enemy force with massed fires of all available weapons.

The senior Army commander is represented at the AOC by the BCE. The BCE is the primary Army link in the exchange of information between the services; however, in joint or combined operations, the AOC includes liaison officers from other services and participating forces.

The AADC controls ADA fires through established rules and procedures. He manages the air battle and the integrated air defense system through a combination of C² systems (positive control) and procedures (procedural control). Avengers are normally employed to support the commander's most critical assets against attack by enemy RISTA, CAS aircraft, and helicopters. They will also find themselves employed in rear areas to defend such critical assets as airports and seaports of entry, C² facilities, logistical bases, air bases, and other key sites in the theater and corps areas. The precise dimensions of various air defense measures, are defined in the ADA Airspace Control Measures table on the next page. For more information concerning multiservice airspace control measures, see FM 100-103-1 and multiservice procedures for integrated combat airspace command and control (ICAC³).

ADA AIRSPACE CONTROL MEASURES

AIR DEFENSE AREA

An air defense area is a specially defined airspace for which air defense must be planned and provided.

AIR DEFENSE IDENTIFICATION ZONE

An ADIZ consists of airspace of defined dimensions that require ready identification, location, and control of airborne vehicles. This is normally the transition procedure that takes place between procedural control (outside) and positive control (inside) in an area of operations.

AIR DEFENSE OPERATIONS AREA

An air defense operations area is an area and the airspace above it within which procedures are established to minimize mutual interference between air defense and other operations. It may include one or more air defense action areas, ADIZs, or firepower umbrellas.

WEAPONS FREE ZONE

A WFZ is an air defense zone established for the protection of key assets where weapon systems may be fired at any target not positively identified as friendly.

WEAPONS ENGAGEMENT ZONE

A WEZ consists of defined dimensions of airspace—such as a FEZ, a high-altitude missile engagement zone (HIMEZ), a low-altitude missile engagement zone (LOMEZ), a joint engagement zone (JEZ), and a short-range air defense engagement zone (SHORADEZ)—in which the responsibility for engagement normally rests with a particular weapon system. The WEZ categories are further defined as follows:

- FEZ. In air defense, a FEZ is the airspace of defined dimensions within which the responsibility for engagement normally rests with fighter aircraft.
 - HIMEZ. In air defense, a HIMEZ is that airspace of defined dimensions within which responsibility for engagement normally rests with high-altitude air defense surface-to-air missiles.
 - LOMEZ. In air defense, a LOMEZ is that airspace of defined dimensions within which the responsibility for engagement normally rests with low- to medium-altitude, surface-to-air missiles.
 - JEZ. A JEZ is airspace of specific dimensions in which friendly surface-to-air missiles and fighters are simultaneously employed and operated.
 - SHORADEZ. In air defense, a SHORADEZ is that airspace of defined dimensions within which the responsibility for engagement normally rests with FAAD air defense weapons. A SHORADEZ may be within a LOMEZ or HIMEZ.
-

COMMUNICATIONS

One of the Avenger platoon leader's most essential systems is his radio system. It is with this system that he is able to command and control his platoon, stay in touch with his battery, monitor the early warning network, and maintain communications with the supported force. Maintenance of radio nets within the platoon and with the supported unit and the parent air defense battery is a challenge for the Avenger platoon leader. He must maintain—

- Control of the air battle.
- Command, administrative, and logistical communications with higher headquarters.
- Contact with supported units.

This section will outline standard communications networks that are used by the Avenger platoon. Unit SOPs will develop networks that modify those described here; however, the Avenger platoon leader must be flexible enough to operate within differing communications networks used by various supported units.

COMMUNICATIONS REQUIREMENTS

As stated above, and in the following table, the minimum communications requirements the platoon leader must maintain include the following nets:

- Battery command net.
- Platoon command net.
- Supported force command net.

- Early warning net.

In all situations, the Avenger platoon leader must comply with communications requirements established in the battery and supported force SOPs.

Communications equipment is often limited, and tactical situations change. Depending on the availability of radios and the tactical situation, the Avenger platoon may be required to operate on the following radio nets:

- Supported force intelligence net.
- Sensor early warning net.
- Supported force ADMIN/LOG net.

**SAMPLE PLATOON
RADIO COMMUNICATIONS
NETWORK**

	Battery Command	Supported Force Command	Platoon Command	EW
Platoon Leader	X	X	X	X
Platoon Sergeant	X	X	X	
Squad Leader		X	X	X
Avenger Squad		X	X	X

Note: METT-T and local SOP will determine which platoon elements will monitor respective communications nets.

Regardless of the tactical situation, the Avenger platoon leader establishes those nets that are required by the supported force or ADA unit being reinforced and complies with SOPs imposed by those forces.

COMMUNICATIONS EQUIPMENT

The Avenger platoon, by nature of its mission, relies on FM radio as its primary method of communications. Each vehicle is equipped with a voice and digital radio, and all vehicles of the platoon monitor the platoon or supported unit net.

The enhanced position location reporting system (EPLRS) provides near-real time secure data communications and unit position location information to support FAAD command and control.

The single-channel ground and airborne radio system (SINCGARS) configuration consists of long- and short-range radios with mounted and dismounted capabilities. When dismounted, the SINCGARS has a line-of-sight (LOS) range of 5 to 10 kilometers for voice and 3 to 5 kilometers for digital data. When mounted, the SINCGARS has a LOS voice range of 10 to 40 kilometers and a digital range of 5 to 25 kilometers. The SINCGARS has the capability to

transmit and receive in a frequency hopset network or in a single-channel network.

MEANS OF COMMUNICATIONS

The Avenger platoon leader can choose from a number of different communications means: wire, radio, messenger, visual, and in the future, digital. Different means should be used when possible so that the platoon does not depend only on one means. Depending on the situation, one means of communications is often more effective than another. The following criteria must be considered when deciding means to use:

- Reliability.
- Installation time.
- Transmission time.

The platoon leader selects the most effective and secure, yet least restrictive, communications means.

Wire Communications

A hot loop should be considered for use with perimeter defenses and other situations when FUs and or friendly units are in proximity. Each ADA squad has a sound-powered telephone (TA-312) and WD-1 wire.

Radio Communications

The radio is the platoon's most flexible means of communications. It can quickly transmit information over long distances with great

accuracy. However, without secure equipment, the radio is vulnerable to enemy interception. All vehicles of the platoon will monitor the platoon net.

Messenger

Using messengers should be a last resort. Messengers are the slowest, least secure method and endanger soldiers.

Visual

Visual communications include pyrotechnics (such as flares and smoke grenades), flags, ground panels, arm and hand signals, and light signals. Visual signals may be per unit SOPs or specially prearranged.

Arm and hand signals are useful when radio or wire is not available, and battlefield noise does not permit use of voice commands. Standard arm and hand signals are found in ARTEP 44-117-21-Drill.

Digital

Digital communications are those communication systems whose primary means of information exchange consists of data. The enhanced position location reporting system (EPLRS) is a digital communications system. The SINCGARS radio can be both digital and voice.

COMMUNICATIONS SECURITY

Communications security measures are employed to safeguard communications. These include all measures taken to avoid enemy detection and to deny the enemy any useful information about friendly forces. The most effective preventive technique is to keep all communications, especially radio transmissions, as short as possible.

Communications security techniques reduce the effectiveness of enemy spot and barrage jamming efforts. Specific procedures are covered in FM 24-33.

CHAPTER 3

FORCE-PROJECTION OPERATIONS

This chapter discusses the role of the Avenger platoon as part of the collection of FAAD weapon systems in force-projection operations. It discusses techniques and special planning considerations needed to support the maneuver force during force-projection operations. The focus is on how to counter and defeat enemy aerial platforms from early entry through postconflict activities. Avenger considerations for each force-projection stage are addressed. The chapter includes discussion on other FAAD systems as well as echelons above platoon level so that Avenger platoon leaders can understand their role in the overall operation.

OVERVIEW

In general, FAAD doctrine for force-projection operations may be applied to both contingency and mature theaters of operations in which a force must operate without US base support, and in which the threat is capable of attacking any point in

the area of operations (AO). The stages of force projection include mobilization (if necessary), predeployment activities, deployment, entry operations (which include expansion and buildup operations), postconflict or postcrisis

CONTENTS

	Page
Overview	3-1
FAADs Role in Force-Projection Operations	3-2
Threat Operational Assumptions	3-3
Tactical Ballistic Missiles	3-3
Low-Altitude Aerial Threat	3-3
Command and Control	3-4
Planning Considerations	3-5
Counter-RISTA Considerations for Avenger	3-7
Tactical Overview	3-7

operations, redeployment, and demobilization. This chapter will primarily

concentrate on the stages of early entry through postconflict operations.

FAAD'S ROLE IN FORCE-PROJECTION OPERATIONS

The overall focus for FAAD is to protect the force from low-altitude aerial threats during force-projection operations. FAAD systems accomplish this by denying enemy intelligence gathering efforts through countering reconnaissance, intelligence, surveillance, and target acquisition (RISTA), reducing the enemy's aerial combat power, allowing the force freedom of maneuver, and protecting the force's critical assets. See the FAAD in Force Projection illustration.

Each FAAD system plays a specific role. Avenger focuses on countering enemy aerial RISTA efforts and providing force protection to the supported force and designated critical assets. The BSFV provides freedom of maneuver to heavy forces, thereby providing the ground force commander with the opportunity to seize the initiative and achieve rapid, decisive victory. Stinger teams are essential for light and special forces and enhancing force protection for heavy forces. Stinger teams provide the flexibility and

FAAD IN FORCE PROJECTION

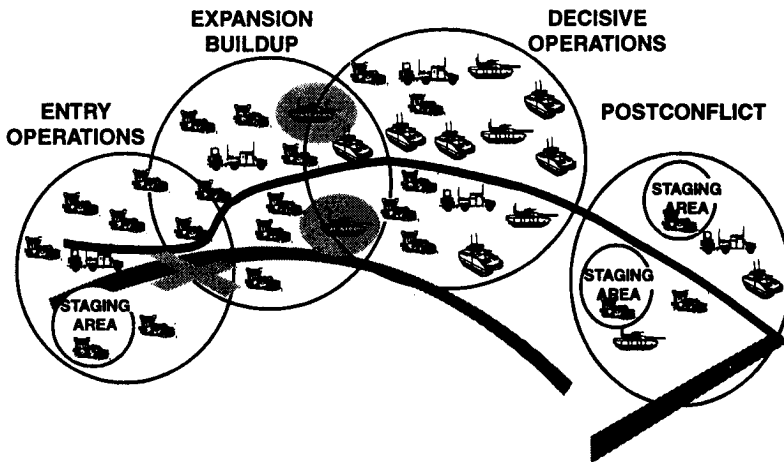

versatility needed on a fluid battlefield by augmenting the coverage of other FAAD systems. FAAD C³I allows for a more effective air defense synchronization by providing detection

and tracking data which support the slew-to-cue requirements, early warning, and situational awareness, as well as reducing the potential for fratricide.

THREAT OPERATIONAL ASSUMPTIONS

Threat tactics will vary by country, and there will be certain universal operational objectives that can be expected by all threat nations. The expected objectives are: to cause massive casualties, interdict force buildup and movement to contact, and minimize their own battle losses. To accomplish

these objectives, threat forces will attempt to make maximum use of their survivable ground-based fire and maneuver systems as their primary weapon systems of choice. Their less-survivable systems and manned aerial assets will be their second choice for munitions delivery.

TACTICAL BALLISTIC MISSILES

Tactical ballistic missiles (TBMs) are the most rapidly spreading air threat system. Their flight profiles do not operate in the low-altitude spectrum, but their targets are found throughout the battlefield framework. TBM targets are mostly stationary sites such as airports, seaports, logistics sites, and battle

command facilities. The TBM threat can exist throughout the duration of US military operations. Although the Avenger is not responsible for countering TBMs, the Avenger platoon leader must be prepared to advise commanders on this threat and passive measures that should be employed.

LOW-ALTITUDE AERIAL THREAT

The primary aerial threats that must be countered by FAAD systems are unmanned aerial vehicles (UAVs), cruise missiles, and rotary- and fixed-wing aircraft. Key characteristics of these priority threats are summarized next.

UNMANNED AERIAL VEHICLES

UAVs include both drones and remotely piloted vehicles. They are inexpensive, easily procured or manufactured, and versatile. There

are over 100 UAV programs being pursued by at least 33 countries. Their small radar cross sections (RCSs) make them very difficult to detect and track. Payloads may consist of radar seekers, high-explosive warheads, FLIR cameras, laser designators, TV, thermal imaging devices, chaff, decoy, and electronic attack capabilities. Ranges can vary from 25 to 800 kilometers, and the upper limit of flight endurance reaches 40 hours. They perform a

wide variety of missions including RISTA, suppression of enemy air defense, ground attack, decoy, communications relay, and chemical detection. The RISTA mission, which uses UAVs to pass real-time information back to threat long-range attack systems, is the greatest near-term concern for forward area air defenders and the force commander.

CRUISE MISSILES

CMs are considered the most stressing threat because of the difficulty in detecting them at launch or during flight, and the inability to destroy them at extended ranges. They can be packaged with a variety of payload options with ranges from 10 to 400 kilometers, and may be launched from the ground, air, or sea. CMs, with their increasing accuracies and warhead diversity, are a potent threat.

ROTARY-WING AIRCRAFT

Versatility and survivability make rotary-wing aircraft ideal for logistics resupply, air assault, command and control, and heavily armed weapons platforms for attack roles. Rotary-wing aircraft cur-

rently exist in every potential theater US forces may enter. Many countries in these theaters possess dedicated attack helicopters. Armed with standoff antitank guided missiles, these helicopters can inflict heavy casualties on the force and destroy critical assets. The proliferation of utility helicopters is also of concern. Utility helicopters, combined with standoff munitions and state-of-the-art target acquisition technology, can produce less expensive, robust helicopter capabilities for any country.

FIXED-WING AIRCRAFT

Although fixed-wing aircraft no longer constitute the principal air threat to ground forces, the following types of fixed-wing aircraft may be employed by the enemy against friendly forces: bombers, fighter-bombers, fighters, and close air support aircraft. Any of the fixed-wing family may carry tactical air-to-surface missiles (TASMs), while only the larger ones will carry CMs. Improvements to fixed-wing aircraft will include increased survivability and improved fire control accuracy.

COMMAND AND CONTROL

An area air defense commander (AADC) designated by the joint task force or theater commander will plan and control air defense operations. The AADC establishes theaterwide rules of engagement. Forces will

receive air defense warnings and weapon control status from the joint force air component commander (JFACC).

Force-projection operations are inherently dynamic. The platoon leader must consider the

following effects on command and control:

- Forces deployed will likely be joint. Joint operations are complex operations defined as integrated military activities of two or more service components of the US military. Their complexity will make command and control more difficult.
- The political concerns used to develop the ROE may conflict with the physical security needs of the force, causing the leader to carefully balance physical security, mission, and ROE.
- The ROE are sometimes established late, requiring flexibility on the part of air defenders.
- The Avenger platoon leader will execute a counter-RISTA

mission as part of a higher headquarters counter-RISTA plan. The primary consideration is security. The mission will be planned at a minimum by the battery commander. Counter-RISTA mission considerations are—

- Security for the ADA fire units throughout the mission.
- Terrain management.
- Airspace coordination.
- Sensor plan to support the mission.
- FAAD C³I support.
- EW plan.
- Mission duration (day and night).
- Logistics plan.

PLANNING CONSIDERATIONS

Avenger platoon leaders need to understand the following basic factors which are common to force-projection stages prior to operations:

- Air defense will be a joint mission. The Air Force, Navy, and Marine Corps air elements will counter the threat fixed-wing assets while the Army and Marine Corps ground air defense units will counter the missile and low RCS threats (UAV, RW, CM, and FW) not destroyed by friendly air defense.
- Whenever possible, US forces will seek unopposed entry. However, in opposed or unopposed entry, operations forces and facilities in and around the debarkation point (APOD, SPOD, staging areas, and

supply points) are extremely vulnerable to air and missile attacks.

- Expansion operations may cover vast distances, as in Operation Desert Storm.
- The ground commander may be forced to accept risk at some stage or stages. The degree of risk he is willing to accept will drive air defense priorities, coverage densities (weighted coverage versus balanced fires), and the number of deployed systems.
- Early deployment of FAAD assets is crucial to the success of entry operations.
- FAAD systems should be oriented to the threat's primary avenue(s) of approach. Balanced fires employment coverage of a

defended asset will be the exception not the norm. Threat aerial movement will be restricted by US and coalition force's fixed-wing air superiority, especially over friendly air space. Threat forces operating UAV and or CM platforms will attempt to use terrain and varied flight profiles to evade US sensors. These routes should be identified during air IPB analysis.

- Avengers deployed in a counter-RISTA role with light and special divisions should be positioned farther forward from the defended assets and units to allow more time to engage because the LSDIS only provides two-dimensional data (azimuth and range). This increases search time for target detection. At a minimum, the following planning considerations (in addition to the commander's intent and priorities, aerial IPB, supported force scheme of maneuver, METT-T, and asset criticality) must be assessed by the Avenger platoon leader during the development of his plan.

THREAT

During the METT-T and IPB analysis, the Avenger platoon leader performs the following tasks to ensure such areas as aerial composition, capabilities, limitations, and ground force dispositions are addressed:

- Identify the number and type of platforms that are projected to be operating within the AO and that pertain to the assigned air defense mission. An example would be RISTA platforms

(UAV, RW, and FW) that may be operating within the assigned sector during a counter-RISTA mission.

- Identify specific capabilities and limitations of sensor and or weapon packages of the projected aerial platforms. Some examples of RISTA platform capabilities are sensor types detection, recognition, and acquisition ranges; downlinks (real time versus nonreal time); relay capability; platform endurance; and platform range. Examples of weapon package capabilities are: maximum ranges, attack profiles, ordnance release points, guidance systems, and warhead types.

- Identify any platform limitations and how they affect the performance of the enemy's mission.

- Address how the presence or absence of enemy ground forces in the AO affects the employment of the Avenger systems.

FRIENDLY FORCES

When performing the following tasks, the platoon leader will address the capabilities and limitations risk areas for the Avenger and other ADA systems during his METT-T and IPB analysis. They are as follows:

- Identify the amount of risk the supported force commander is willing to accept and how it affects the employment of the Avenger fire units.

- Identify Avenger weapon system and FAAD sensor capabilities and limitations against the projected

aerial threat and address how they affect the air defense plan. An example of this is the Stinger missile's engagement capability versus a UAV with standoff capability.

- Identify other available ADA systems operating within

the AO and address how they contribute or hinder the air defense plan (that is, having only one sensor [GBS or LSDIS] may affect employment of the weapon systems).

COUNTER-RISTA CONSIDERATIONS FOR AVENGER

Avenger should be the FAAD system of choice in countering enemy aerial RISTA platforms. Avenger is the most effective FAAD system capable of receiving and using a C³I cue. The weapon system provides rapid reaction and multiple engagements within seconds. The Stinger missile's limited engagement range against UAVs may be overcome by sound IPB, positioning well forward from the defended asset, and the ability of the Avenger to use C³I data.

When conducting a counter-RISTA defense for critical assets, Avenger should be positioned far enough forward and away from the asset (along anticipated air avenues of approach) to negate an enemy UAV's standoff detection capabilities (most stressing aerial RISTA threat). See Avenger Employment During Expansion and Buildup paragraph on page 3-13. A current planning factor of deploying 5 to 7

kilometers forward and away from the asset should be used. This planning factor is threat-dependent and FU security-dependent. The employment distance may vary by country and region depending on aerial platform capabilities. The standoff UAV must close to within a specific range of the critical asset and at a low altitude to obtain discrete target recognition. With Avenger positioned forward and out from the asset, the UAV will be well within the Stinger missile's engagement envelope prior to collecting any target information. Positioning the fire unit too close to the critical asset may result in its inability to engage the UAV before it obtains RISTA data. By developing his air defense plan to counter the standoff UAV, the Avenger platoon leader will also enable his fire units to counter other aerial platforms (RW, FW, and CM) prior to ordnance release.

TACTICAL OVERVIEW

The entry operation is the most vulnerable period when preparing for war, and the Avenger platoon will most likely be one of

the first units deployed to defend the entry area. The platoon leader must ensure that his platoon is combat ready to include training,

physically and mentally, for this type of operation.

ENTRY OPERATIONS

An example of a joint force entry operation may begin by forces deploying from CONUS and other locations via airlift and sealift for ports of debarkation contained within or near the area(s) of operations. Upon debarkation, the forces are marshaled into staging areas to prepare for future operations or further movements. Deploying forces are most vulnerable, and the success of the operation is at greatest risk, during initial entry operations, especially forced entry operations. Aerial ports and seaports of debarkation (APODs and SPODs), as well as staging areas, will be lucrative targets for threat aerial platforms. Throughout this stage, enemy UAVs conducting RISTA missions can reveal details about arriving forces and provide targeting information to long-range attack systems.

The FAAD mission during this stage focuses on denying enemy aerial RISTA efforts. FAAD weapon systems and FAAD C³I (Avenger and GBS) should be deployed within the earliest airlifts to ensure composite defense against the threat spectrum. Avenger will provide the requisite firepower and mobility to accomplish the counter-RISTA mission with required alerting and cueing data provided by the GBS. In addition to integrating with other

Army air defense artillery systems, FAAD elements integrate their weapon and sensor coverages with deployed joint and combined arms defenses.

Protection of forces and equipment in this stage requires FAAD systems to be positioned to maximize overlapping fires, but depend on the factors of air IPB, METT-T, and asset criticality. Positioning based on an in-depth IPB will provide for defense against threat aerial platforms.

The Avenger platoon leader must deny the enemy his "eyes." Avenger must be positioned to negate aerial RISTA platform detection capabilities. At a minimum, when planning air defense protection, the Avenger platoon leader must consider the commander's intent and priorities, aerial IPB, support force scheme of maneuver, METT-T, and asset criticality. Stinger teams and ground protection from the maneuver force may be deployed to augment Avenger platoon coverage during this stage of operations. The Avenger platoon leader may rely on liaison or coordination with the USAF for long-range early warning information until the battery or battalion C³I elements arrive. The platoon leader should check first to see if corps or echelons above corps (EAC) theater missile defense (TMD) has deployed early to counter ballistic missile threats; this would mean liaison teams may already be established for early

warning information. Avenger platoons must receive early warning from one of the options. Early warning is a must if the Avengers are to be effective. See the FAAD in Entry Operations illustration.

The Avenger platoon leader must ensure integration of his tire units into the battery and other air defense weapon systems planning

and coverage as follow-on forces arrive. As heavy forces are introduced into the entry operations, they will deploy with their organic FAAD battalions and additional follow-on corps ADA brigade elements. The Avenger platoon leaders will be relieved on order and will move with the rest of the battery to provide air defense for their brigade and divisional force assets.

FAAD IN ENTRY OPERATIONS

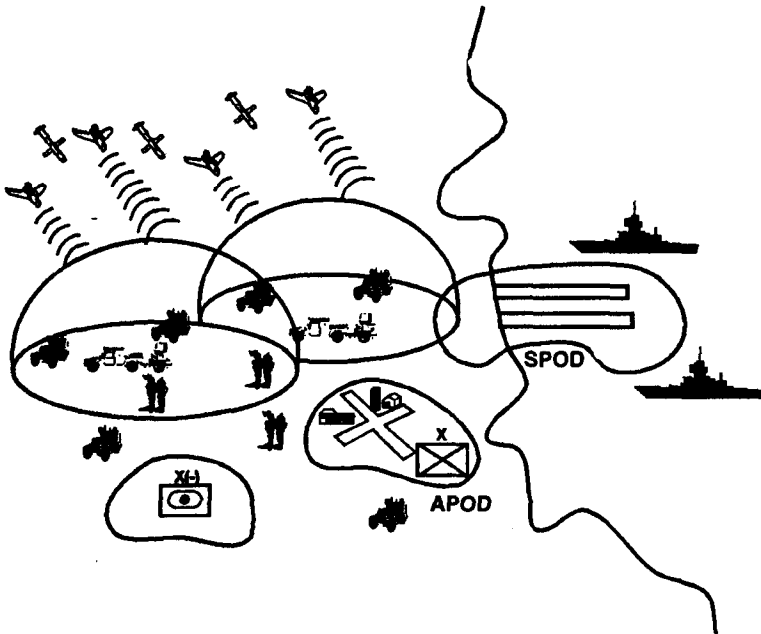

Threat in Entry Operations

Early-on entry forces may debark and deploy in an air inferiority or air parity environment. The threat will have more available air assets during this stage than any other. He can be expected to use all aerial platform types (TBM, UAV, RW, CM, and FW) against lucrative targets in the areas of debarkation. UAVs will conduct RISTA operations to primarily gather battle damage assessment (BDA), and intelligence and targeting information of troop and logistical concentrations. Low-altitude aerial threats (RW, CM, and FW) will be employed in attack operations against APODs, SPODs, assembly areas, and supply points.

Operations for Avenger During Entry Operations

Early-entry FAAD elements (Avenger, GBS, and LSDIS) must integrate their AD coverage with those of the joint and combined air defense assets. Entry operations will primarily be a corps or EAC responsibility. This corps and EAC ADA brigade can be expected to deploy the initial FAAD forces in country. These forces will provide protection for the ports of debarkation and initial assembly and staging areas. Follow-on corps and EAC FAAD elements should be used to augment division ADA requirements as needed. This follows the higher-to-lower support philosophy.

The counter-RISTA defense of protected forces and assets in this stage requires Avengers to be positioned to maximize early engagement depending on the air IPB, METT-T, asset criticality, and the amount of risk the supported force commander is willing to accept. See the Avenger in Entry Operations illustration. This positioning, based on an in-depth air IPB and METT-T, will provide for defense against RISTA UAVs and, in turn, other low RCS threats. Note: Avenger platoon leaders should develop their plans to negate the most stressing threat (that is, standoff UAV detection range versus RW and FW ordnance release points). By focusing their plan in this manner, all other low-altitude threats should enter within the engagement envelopes of the Avenger fire units prior to becoming threats to the force. MANPADS teams may be deployed to augment Avenger platoon coverage during this stage.

The Avenger platoon must take advantage of its mobility to ensure its survivability while giving maximum air defense protection to the supported force and critical assets. Avenger fire units must conduct rapid movement to selected positions upon debarkation and quickly become operational.

AVENGER IN ENTRY OPERATIONS

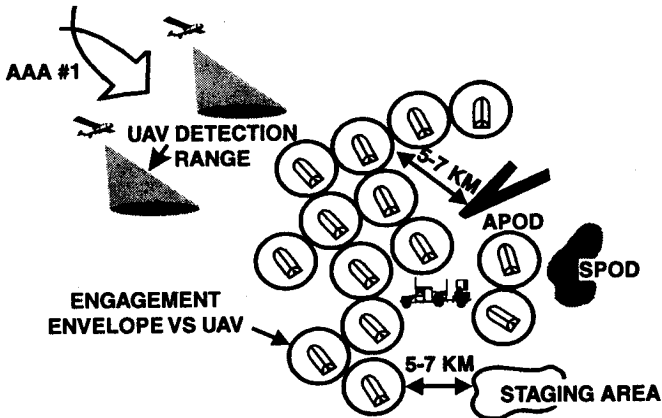

**EXPANSION AND
BUILDUP OPERATIONS**

Expansion and buildup operations set the conditions for victory. Buildup in combat power, supporting forces, and equipment occurs during this phase of operations. Expansion of the force and rapid buildup may include establishing forward operating and logistics bases, expanding the lodgement, closing the remainder of the force in country, linking up with other forces, and preparing for future operations. During this phase, units road march or conduct movement to TAAs. These movements can be quite extensive, up to several hundred kilometers. Within the assembly areas, units are equipped, rehearsed, and prepared to initiate operations.

The FAAD counter-RISTA systems of choice are the Avenger, GBS, and FAAD C³I. Denial of

threat observation of force composition and routes of movement will require that the Avenger weapon systems and sensors be pre-positioned along the routes and or positioned with the screening force to allow for tactical flexibility. See the FAAD Employment During the Expansion Phase (Road March) illustration on the next page. Stinger and BSFV may be required to augment the defense. The Avenger platoon leader will position his squads and teams in such a manner as to ensure that threat aerial RISTA platforms cannot observe friendly force movement or assets. Avenger platoons should be prepared to conduct the counter-RISTA mission well forward and to the flanks of the route areas, ensuring continued denial of threat aerial information gathering efforts.

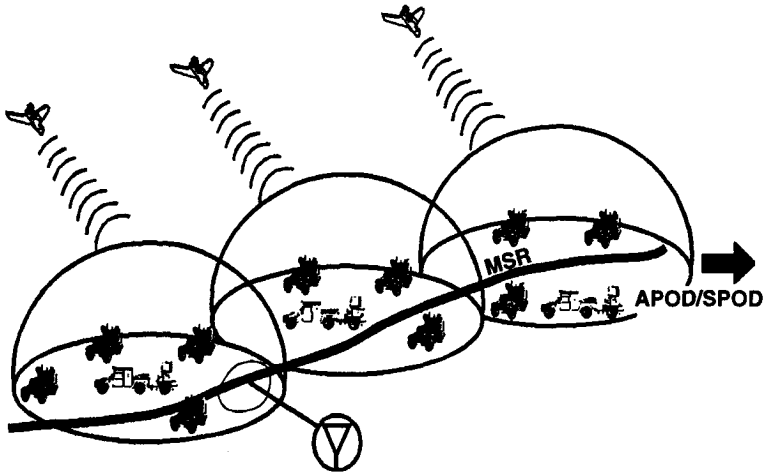
FAAD EMPLOYMENT DURING THE
EXPANSION PHASE (ROAD MARCH)



**THREAT IN EXPANSION
AND BUILDUP**

The threat will focus on conducting RISTA operations to locate unit movements, determine unit sizes and strengths, and postulate their ultimate destinations. UAVs will be the primary aerial RISTA platform. Information obtained by UAVs will be relayed back to the enemy who uses any attack means necessary to inflict maximum casualties, inhibit momentum, and destroy forces. These attack means may include lethal UAVs, cruise missiles, and rotary- and fixed-wing aircraft.

**AVENGER IN EXPANSION
AND BUILDUP**

During movement, the denial of threat aerial observation of force composition and direction and routes requires FAAD elements (Avenger, GBS, and LSDIS) to be pre-positioned along the routes. The magnitude and duration of the counter-RISTA defense are dependent upon the amount of risk to the force the supported force commander is willing to accept. The least risky operations essentially call for a concentrated employment of weapon systems and sensors deployed along the entire route for the

AVENGER EMPLOYMENT DURING EXPANSION AND BUILDUP

length of time needed to move the force. This employment is asset intensive and unrealistic because the FAAD mission for entry operations is still ongoing. The combination of the two missions requires the employment of both corps and EAC and divisional FAAD assets. A more probable approach will incorporate some degree of risk into the defense, thus requiring fewer fire units and sensors.

Avengers should be employed to maximize early engagement. If risk is accepted, FUs can be employed with gaps between systems. See the Avenger in Counter-RISTA Role During Movement illustration. Deployment, weighted toward the anticipated air avenues of approach, could effectively counter route observation by a UAV using a standoff loiter, direct fly-over, or zig-zag profile. See the Flight Profiles for UAVs illustration.

AVENGER IN COUNTER-RISTA ROLE DURING MOVEMENT

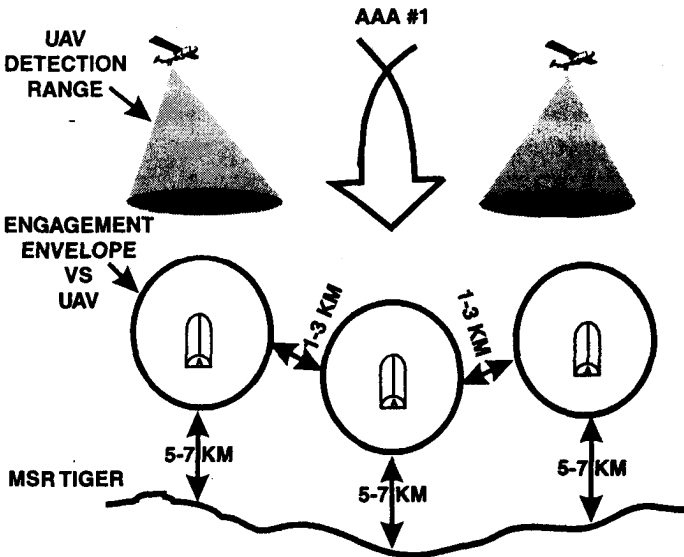

Deploying Avengers with gaps between coverage requires fewer fire units than deploying Avengers that have overlapping or touching coverage for the same route distance. Some risk is incorporated into the air defense plan, but is acceptable. This spacing is

not only predicated on IPB and forward positioning, but is also based on the improbability of a threat aerial platform having detailed IPB of air defense coverage, flying a perfect course between the deployed Avengers, and reaching the target area.

FLIGHT PROFILES FOR UAV

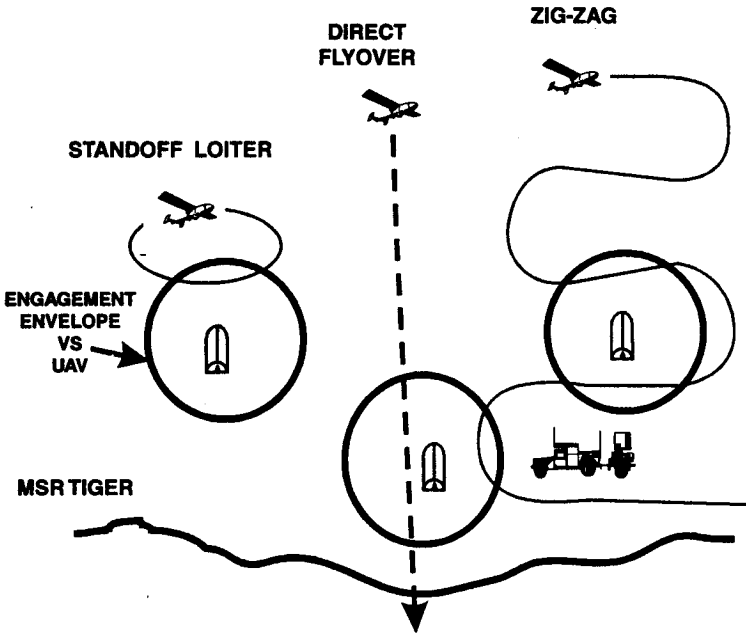

Avengers protecting the TAAs will be positioned well forward and to the flanks of the assembly area, to deny enemy aerial RISTA. The maneuver force will be positioned in the TAAs for final preparation just prior to launching the attack. Stinger MANPADS teams augment air defense coverage, and BSFVs are positioned with their supported maneuver element preparing to conduct operations with the maneuver force. The low-altitude air defense mission is to ensure that the supported force commander retains the element of surprise and the ability to mass his forces at the place and time he chooses. See the TAA Protected by FAAD (Expansion and Buildup Phase) illustration.

Passive defense measures should be the dominant deployment guideline for forces located in TAAs. Concealment and surprise must be maintained. Avengers, supported by GBS and LSDIS, provide counter-RISTA protection maximizing early engagement. See the TAA Defended by Avenger illustration on the next page. Avengers should be ready to engage any aerial threat (RW, CM, and FW) but should only do so if they or the force is attacked. Avenger sections must understand that most threat RISTA assets (UAVs, RW, and FW) have the ability to rapidly disseminate intelligence information. Priority for Avenger deployment should be to deny the enemy this capability.

**TAA PROTECTED BY FAAD
(EXPANSION AND BUILDUP PHASE)**

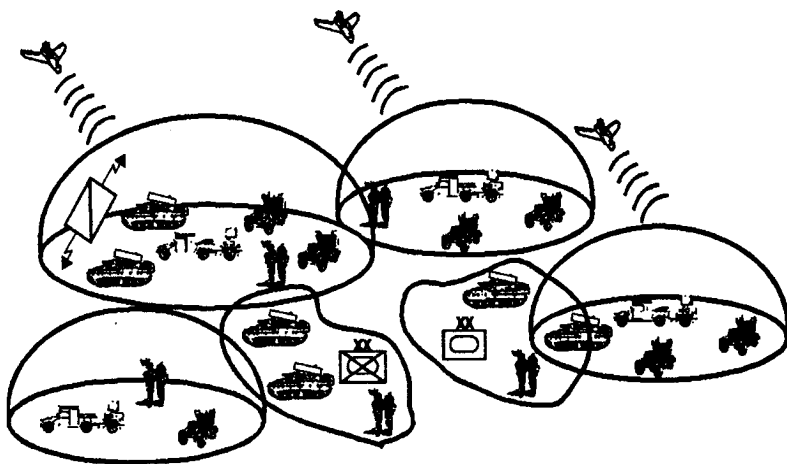

TAA DEFENDED BY AVENGER

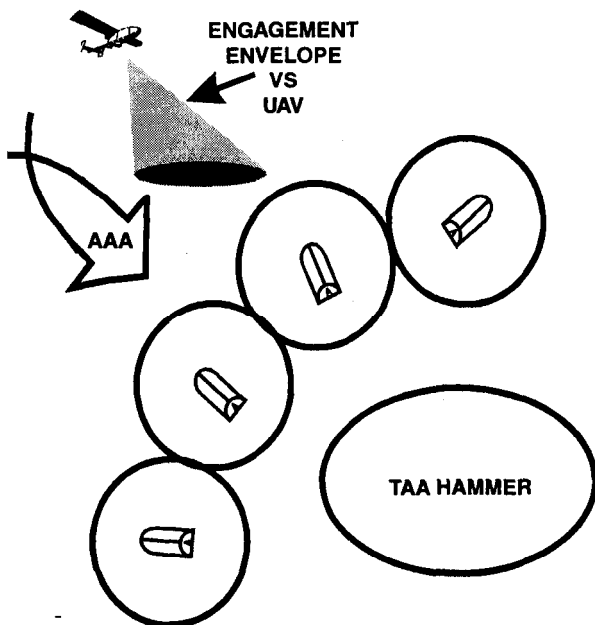

OPERATIONS

During operations, maneuver forces deploy out of TAAs and into attack formations that facilitate movement and mass sufficient combat power to ensure decisive victory. Commanders adjust their tempo appropriately as they anticipate closing with enemy forces. They decide where their forces can deploy into formations that facilitate the initial contact and still provide freedom of action for the bulk of their

forces. Avenger and FAAD C³I will be deployed with the covering force, along the flanks and in overwatch positions, of the maneuver force and continue to deny threat aerial RISTA efforts while protecting the movement. BSFV platoons deploy with their maneuver elements. Stinger MANPADS augment air defense coverage of the maneuver force. See the FAAD Operations (When Deploying From a TAA) illustration.

FAAD OPERATIONS (WHEN DEPLOYING FROM A TAA)

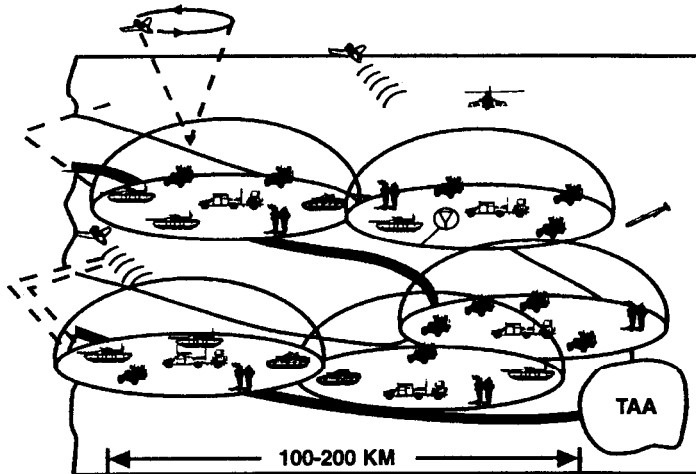

The threat will attempt to counter the attack with a myriad of aerial platforms. RISTA UAVs will seek to determine friendly unit locations, movements, and objectives. Aerial and artillery strikes will be generated from the intelligence gathered against targets such as the maneuver force, forward area rearm and refuel points (FARPs), aviation forward operating bases (FOBs), command and control nodes, reserve troop concentrations, logistical support areas, and terrain features or obstacles which could constrict unit movements, thereby resulting in massed forces. Lethal UAVs can be expected to be employed against maneuver forces as they advance towards and close with enemy forces. The lethal UAVs, if used for such

purpose, can be effective at disabling FAAD CI or destroying armored vehicles. Cruise missiles will be targeted against logistical concentrations and command and control nodes. Rotary-wing aircraft will be used to attack the forward elements and the flanks of the advancing maneuver forces to slow their tempo, cause confusion, and thereby inflict maximum casualties. They will also conduct operations, cross-forward line of own troops (FLOT), close air support (CAS), and air insertion operations. These attack and armed helicopters constitute the most widespread and capable air threats to ground forces in the close battle.

During this stage of force-projection operations, the primary

focus of FAAD weapon systems shifts from counter-RISTA to force protection. Avenger will be deployed along the flanks of the maneuvering force (IPB and METT-T dependent) to defend against rotary-wing aircraft and lethal UAVs, and to counter enemy aerial RISTA efforts. Stinger augments the air defense coverage and provides flexible force protection to the AD commanders. BSFVs in support of

maneuver units will be primarily used to counter threats such as RW and lethal UAVs. FAAD C³I elements must preplan positions throughout the area of operations and then occupy those positions to ensure continuous extended coverage and cueing information is provided to FAAD systems supporting the force. See the FAAD Protection During Maneuver Operations illustration.

FAAD PROTECTION DURING MANEUVER OPERATIONS

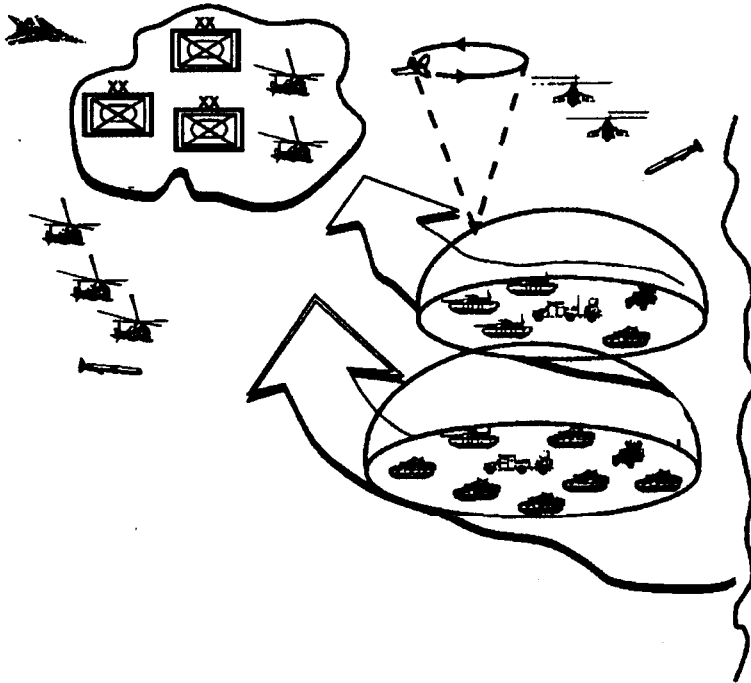

Postconflict Operations

At the close of the decisive battle, friendly forces may be required to prepare for follow-on operations. They must rearm, refuel, and reconstitute personnel and equipment. Friendly forces are extremely vulnerable while conducting these types of activities. They become lucrative targets for enemy long-range strike systems which are able to detect and target them based on information received from enemy RISTA UAVs. Low-altitude air defense, primarily Avengers, shield the force from the enemy reconnaissance and attack and ensure success of future operations.

During postconflict operations, friendly forces are marshaled into staging areas for follow-on operations

or redeployment. Forces will either be redeployed to another theater of operation or back to CONUS.

While the most significant aerial attack capabilities may have been eliminated, friendly forces must be prepared to counter isolated air and missile attacks from any remaining threat forces. Avenger platoons will be primarily concerned with countering potential enemy RISTA efforts, thereby providing force security and preventing surprise attacks. These actions allow for unimpeded reconstitution and unharassed redeployment of forces. FAAD systems in postconflict operations will defend in the same manner as in entry operations.

CHAPTER 4

OFFENSIVE AND DEFENSIVE OPERATIONS

This chapter describes how the Avenger platoon operates during offensive and defensive operations to include reconnaissance and security operations. The Avenger platoon's focus during offensive and defensive operations will shift from counter-RISTA to force protection as the operations become decisive.

OFFENSE

The offense is the decisive form of combat. Army operational doctrine seeks to seize the initiative quickly and achieve decisive victory

with minimum casualties. This segment describes how the Avenger platoon operates during offensive operations.

CONTENTS

	Page
Offense	4-0
Purpose of the Offense	4-1
Threat in the Defense	4-1
Avenger in the Offense	4-2
Avenger and Forms of Tactical Offensive Operations	4-6
Avenger in Light and Special Divisions Operations	4-9
Defense	4-11
Threat in the Offense	4-12
Avenger Planning Considerations in the Defense	4-12
Avenger Coverage in a Defense in Sector	4-15
Defense of a Strong Point	4-16
Counterattack	4-17
Perimeter Defense	4-18
Reconnaissance Operations	4-19
Avenger in Reconnaissance Operations	4-19
Security Operations	4-20
Avenger in Security Operations	4-20
Covering Force Operations	4-20
Avenger in Covering Force Operations	4-21

PURPOSE OF THE OFFENSE

The main purpose of the offense is to defeat, by destroying or neutralizing, an enemy force. Offensive operations are undertaken to—

- Secure decisive terrain.
- Deprive the enemy of resources.

- Gain information.
- Disrupt an enemy attack.
- Deceive and divert the enemy.
- Hold the enemy in position.
- Setup conditions for future successful operations.

THREAT IN THE DEFENSE

During friendly offensive operations, threat forces will attempt to use their maneuver and fire support assets to regain the initiative. Threat air activity will most likely be categorized by RISTA operations in support of artillery and maneuver. UAVs are best suited for these types of operations, especially if threat forces have developed effective C³I. Secondary weapon systems the enemy will use are helicopters, either as dedicated attack assets or as armed utility helicopters. Helicopter assets can be used in three roles—attack, air insertion, or reconnaissance. Helicopters in the reconnaissance role will operate in the same manner as UAVs to support artillery targeting and maneuver. In the attack, the air defender can expect spoiling attacks that usually consist of at least two helicopters or more (taking full advantage of

cover and concealment) with the mission of disrupting friendly operations.

In some cases, helicopters will be used in conjunction with threat armored forces to deter friendly penetrations. However, it is unlikely the friendly commander will see large numbers of helicopters in this role. The enemy may use ground forces to first neutralize friendly air defense assets. Helicopters will be used as the primary CAS aerial platform against maneuver forces.

Threat fixed-wing assets will be limited, and their use will be hampered by friendly fixed-wing aircraft. Use of enemy fixed-wing aerial platforms cannot be entirely ruled out. If used by the enemy, the ground commander can expect to see no more than one or two aircraft in a spoiling attack, normally not coordinated with enemy ground operations.

AVENGER IN THE OFFENSE

Offensive operations are characterized by momentum, initiative on the part of subordinate commanders, and the ability to make rapid shifts in the main effort to take advantage of opportunities and rapid penetrations.

The Avengers may follow the brigade in zone, providing overwatch and protecting command and control, reserves, and artillery units. The decision to employ the Avenger unit forward requires a thorough understanding of the commander's intent and the establishment of disengagement criteria. Planning for this operation should include the following risk considerations when deploying Avenger forward in support of maneuver forces:

- Avengers are light-skinned vehicles with a distinct high profile. They are extremely vulnerable to direct fire, small arms, and indirect fire.
- The maneuverability of a fully combat-loaded Avenger is less than that of supported maneuver forces. The vehicle is somewhat top-heavy and unable to negotiate rugged terrain with side slopes exceeding 22 degrees.
- The span of control for an Avenger platoon is great. Consequently, the ability of the Avenger platoon leader to control a platoon of six Avengers on the move in support of a deployed task force is complex.

Avenger's involvement in offensive operations is different from

other FAAD weapons. Bradley Stinger Fighting Vehicle (BSFV) platoons and MANPADS are integrated into a task force scheme of maneuver. These systems usually have a direct support (DS) relationship with their supported unit. Avengers are normally in a GS and GS-R role. However, Avengers can be in DS relationships. Avenger may be used in the direct support role, especially in light and special divisions. At night, in adverse weather and when no other ADA system can perform the ADA mission, the Avenger can be integrated into light battalion's scheme of maneuver.

Avenger platoon, section, and squad leaders must understand how offensive operations enhance existing FAAD systems coverage, and coverage for priorities other FAAD systems cannot perform and are Avenger-unique such as the counter-RISTA function. Examples of Avenger's involvement in offensive operations are—

- Reinforcing (R) or GS-R to a BSFV platoon and or MANPADS.
- Providing GS air defense to CSS, FS, and C assets.
- Assisting and augmenting air defense for choke points and breaching operations. See Avenger in Breaching Operations (R) to BSFV Platoon—Phase 1, —Phase 2, and —Phase 3 illustrations on the following three pages.

AVENGER IN BREACHING OPERATIONS (R) TO
BSFV PLATOON-PHASE 1

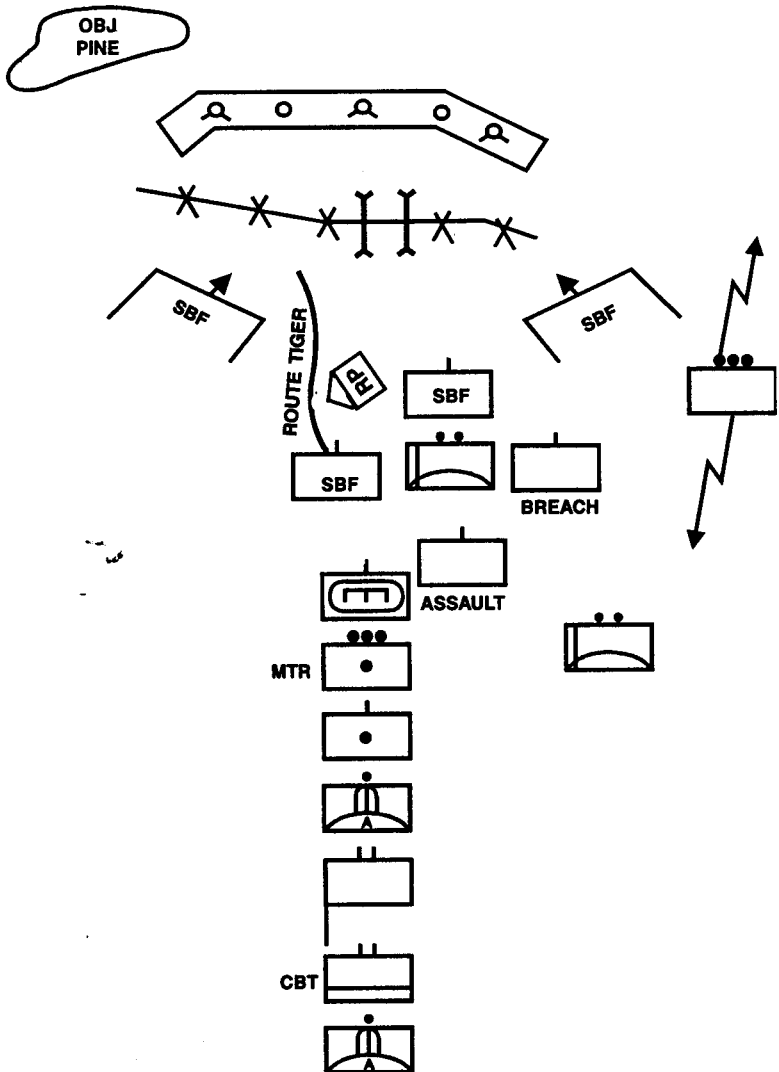

AVENGER IN BREACHING OPERATIONS (R) TO
BSFV PLATOON-PHASE 2

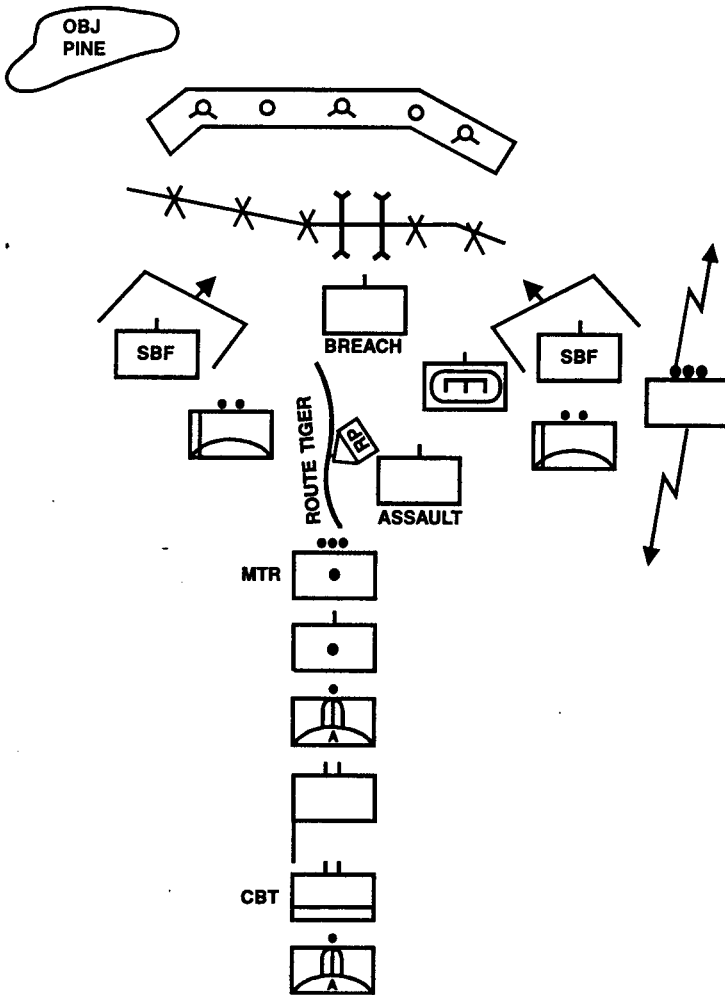

AVENGER IN BREACHING OPERATIONS (R) TO
BSFV PLATOON-PHASE 3

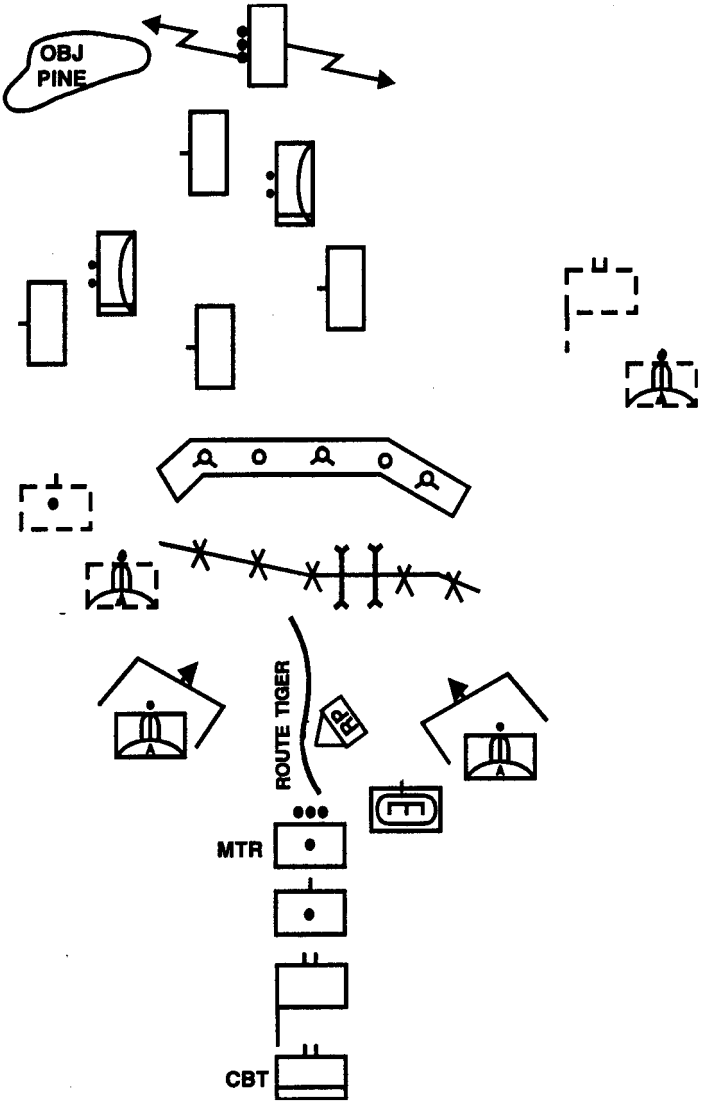

AVENGER AND FORMS OF TACTICAL OFFENSIVE OPERATIONS

A task force may conduct various types of offensive operations. Each requires the platoon leader to plan, using the six ADA employment guidelines outlined in Chapter 2. Avenger platoon, section, and squad leaders must determine Avenger's involvement in offensive operations. They must ensure Avengers stay out of direct fire range yet maintain pace with the supported unit for adequate coverage. Preplanning positions throughout the zone that support the

operation and the command and control of the Avenger FUs is key.

Avenger FU are light-skinned vehicles and should not be integrated into the task force when meeting contact is expected. The Avenger may be positioned on the maneuver force flank and rear where it is best suited to defend enemy air avenues of approach. See Avenger Protecting Maneuver Force Flanks and Rear from Air Attack illustration.

Understanding the supported unit's scheme of maneuver is the first

AVENGER PROTECTING MANEUVER FORCE FLANKS AND REAR FROM AIR ATTACK

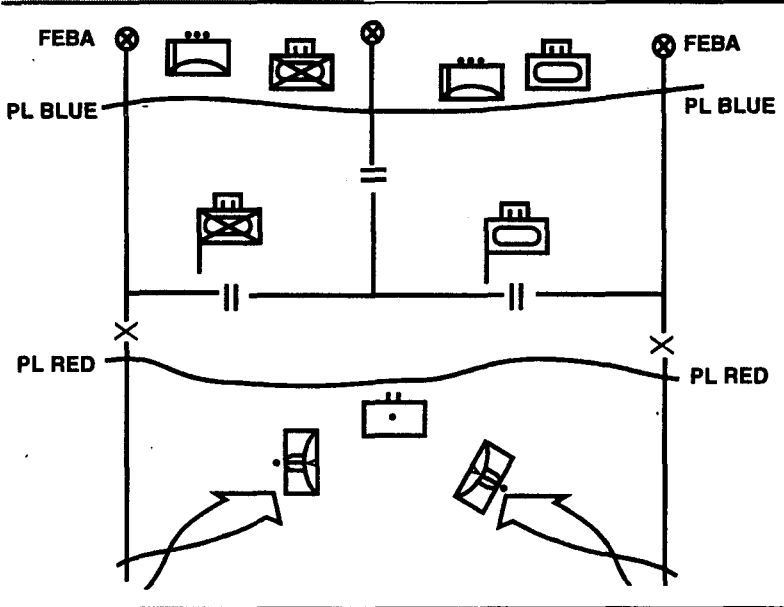

step in providing adequate air defense. The forms of tactical offensive operations are discussed in the following paragraphs (see the Avenger Protecting Maneuver Force Flanks and Rear From Air Attack illustration).

MOVEMENT TO CONTACT

The movement to contact (MTC) is conducted to make or regain contact with the enemy or to develop the situation. Task forces conduct MTCs independently or as part of a larger force. A task force will normally be given an MTC mission as the lead element of a brigade attack or as a counterattack element of a brigade or division. MTC terminates when the assigned objective is occupied or when enemy resistance requires the battalion to attack to continue forward movement attacks.

Enemy air can be expected if the friendly attack is achieving success. Avenger platoon leaders will normally design their coverage in conjunction with the task force commander's scheme of maneuver and any TF DS ADA assets.

An MTC usually results in lateral maneuver once the enemy is located and the task force attempts to either fix or bypass. Avenger platoon leaders must remain flexible, and planning for a movement to contact must include analysis of enemy air avenues throughout the

entire zone. Avenger platoons must be in a posture to quickly counter any enemy air threat.

During the MTC, the Avenger platoon will be employed to protect critical assets, such as the maneuver forces reserve, field artillery, C², and logistics. The Avenger can be used to provide coverage for choke points along the march route or to defend the maneuver force as it moves prior to contact. Friendly forces must maintain forward momentum. Enemy forces must be denied intelligence on our movements. The platoon leader should position his sections and squad so that two-thirds of the weapon system's effective range extends in front of the maneuver force, if possible.

HASTY ATTACK

Hasty attacks are conducted either as a result of a movement to contact or when bypass has not been authorized, and the enemy is in a vulnerable (unaware or unprepared) position. The two categories of hasty attacks are an attack against a moving enemy force and a stationary enemy force.

The success of air defense artillery in a hasty attack will depend on thorough prior planning. Prior to the mission, on-order Avenger positions, aerial NAIs and TAIs along suspected enemy air avenues of approach, and decision and execution matrices must

be developed throughout the entire zone to ensure success. The Avenger platoon leader will plan his scheme of maneuver based on the task force scheme of maneuver, ADA, priorities, and any DS ADA assets. Unit SOPs and battle drills, combined with rapid, aggressive execution, will aid in mission accomplishment.

DELIBERATE ATTACK

Task force deliberate attacks differ from the hasty attack in that they are characterized by precise planning based on detailed information, thorough preparation, and rehearsals. Deliberate attacks normally include large volumes of supporting fires, main and supporting attacks, and deception measures.

The deliberate attack allows more time for detailed IPB and detailed preplanned positions throughout the entire zone. For a deliberate attack, air defense coverage must be extensive and well-coordinated. This requires a complete IPB process that must include—

- Ground and air avenues of approach.
- Aerial NAIs and TAIs designated along air avenues of approach.
- Aerial attack profiles.
- Probable enemy aviation fire sacks.
- Aerial surveillance positions and routes.

From the IPB, the Avenger platoon leader will develop and use his own graphic control measures and those directed by the supported unit

to control fire unit movement. Avengers are positioned to support the TF scheme of maneuver, enhance TF DS ADA assets, and or protect CSS, C², and FS assets. The Avenger platoon leader must, however, retain the flexibility to shift and redirect platoon fires in support of the entire zone.

EXPLOITATION

Exploitation follows any successful attack and is conducted to take advantage of the success. The task force normally participates in the exploitation as part of a larger force.

ADA resources supporting an exploiting task force must be as mobile and survivable as the maneuver force. Less mobile and survivable fire units are used to keep task force lines of communications open and protect key logistics facilities and command and control posts. Effective command and control is critical to support constantly moving units.

PURSUIT

The purpose of the pursuit is to run the enemy down and destroy him. The pursuit is oriented on the enemy rather than on terrain objectives and normally follows a successful exploitation.

As with the exploitation, air defense systems deployed with the enveloping forces must be as mobile as the supported force. Since penetration occurs deep in the enemy rear, the same caution as in a movement to contact must be

practiced. Avenger's involvement will be focused on CSS, C², FS, and

maneuver reserve air defense coverage.

AVENGER IN LIGHT AND SPECIAL DIVISIONS OPERATIONS

The Avenger squad, section, or platoon may be deployed to fight and protect within the scope and design of any organization. Light and special divisions operations concerning forms of maneuver are different from the heavy division. The platoon must train to fight, based on what organization it is supporting. The following paragraphs discuss the forms of a maneuver unit.

SPECIAL OPERATIONS

The purpose and characteristics of offensive operations remain the same for units in light and special divisions. There are unique considerations concerning the forms of maneuver. Avenger leaders need to be familiar with them to understand the scheme of maneuver. For more information concerning these forms of maneuver and their relation to light units, see the recommended reading list in the Preface (especially FMs 7-8, 7-20, and 7-30).

Infiltration

The purpose of the infiltration is to move by stealth to place a maneuver force in a more favorable position to accomplish the mission. Infiltration is the preferred infantry maneuver, because it allows a smaller force to use stealth and surprise to attack a larger or fortified

force. The three types of infiltration are land, water, and air.

Penetration

The infantry concentrates in a penetration to strike at the enemy's weakest point, then break through to rupture the enemy's defense. Stealth, limited visibility, and use of covered and concealing terrain at a selected breach point characterize the penetration.

Envelopment

The envelopment is the basic form of maneuver. It seeks to apply friendly strengths against enemy weaknesses by striking the flanks or rear. This causes the enemy to fight along undefended or lightly defended avenues of approach. Envelopment can also interdict lines of communications (LOC).

Turning Movement

The attacking force making the turning movement passes around the enemy, avoiding him entirely to secure an objective deep in the enemy's rear area. The objective must be along the enemy's LOC and be of enough importance to cause him to abandon his forward defenses.

Frontal Attack

The least desirable form of maneuver is the frontal attack. The most direct routes are used to strike the enemy along his front. When possible, the objective should be seized from a direction other than the front.

AVENGER CONSIDERATIONS

The use of stealth throughout the forms of maneuver for light units will often preclude the direct use of Avenger in light operations. As mentioned in Chapter 5, the Avenger's profile limits its use when stealth is desired. Avenger's use in support of light units' offensive operations follows the same principles as with heavy forces. MANPADS teams are often more suited for the early stages of offensive operations. For example, MANPADS teams are obviously more suited for an air or foot infiltration; however, Avenger would be critical to securing a pickup zone (PZ). Light units' dependence on limited visibility conditions may involve Avenger in some stages of an operation, but Avenger's optics advantages would have to greatly outweigh the risk to the system. In this chapter, Avenger employment considerations in light and special units are addressed.

General Considerations

The platoon leader must consider a variety of factors to properly integrate his FUs. The following paragraphs will discuss some of the

factors the Avenger leader must consider when integrating his FUs into light and special divisions of offensive operations.

Stealth. As mentioned above, stealth is a primary consideration for light operations. Squads must consider they are easy to identify. There are ways to minimize this. Using the blast shield at night to reduce the back lighting effect by the FLIR will help. Placing the RCU in a fighting position and covering it will also reduce light signatures. Also, the squad must be able to hear. Wearing CVC helmets limits the soldier's ability to hear outside noises and how much noise he is making.

Security. If a squad does not have additional security, the squad will be at risk.

Threat. Light battalion maneuver elements are not as high a priority as other elements which are easier to identify. The enemy can have a greater impact on a brigade's combat power by damaging its FS, CSS, C², and aviation assets. Each of these elements is easier to find than an infantry company dispersed in concealed terrain.

Avenger capabilities. There are situations when the Avenger is the only system capable of performing the ADA mission. At night, when the enemy is night capable, Avengers may be used in direct support of TFs and company teams. When the weather

or smoke limits visibility, the Avenger is the only system capable of dealing with these situations. All situations must consider the inherent risks.

Movement to Contact

The approach march technique and the search and attack technique are used by infantry battalions to conduct the movement to contact. MANPADS will be used in support of the main body and advanced guard in the approach march technique, and Avenger may be used in overwatch positions when additional security is available. Avenger will support FS, CSS, C², aviation assets, and reserve forces. Reserve forces such as tank and mechanized companies in support of light battalions are an enemy high-value target. During search and attack operations when an area of operations may be occupied for a longer period of time, Avenger will be used to achieve early engagement on likely air avenues of approach. Security for squads is critical and must be coordinated.

Breaching Operations

Breaching operations principles are used extensively by light units. Attacks on fortified positions

and strong points follow the suppress, obscure, secure, and reduce (SOSR) principles. Avenger's involvement in breaching operations occurs in later phases. When the breach site is secure and units supporting the maneuver elements must move through, Avenger will provide air defense of the existing choke point. This is especially important when FS and C² assets must move through.

Degraded

Avenger Operations

A unique light unit Avenger consideration is that of degraded Avenger operations for other than system failures. The commander or platoon leader should make this decision as a last resort. Consider the following if reverting to MANPADS when the system is still viable:

- Level of the squad's MANPADS training (target engagement and physical conditioning).
- Security of the vehicle and remaining missiles.
- Degraded detection and engagement capabilities with loss of optics and laser range finder.
- Degraded C² due to reduction of communications capability.

DEFENSE

US military forces defend only until they gain sufficient strength to attack. Commanders choose to defend when they need to buy time, hold a piece of key

terrain, facilitate other operations, preoccupy the enemy, or erode enemy resources at a rapid rate while reinforcing friendly operations. Maneuver units defend in

sector from battle positions and from strong points.

The purpose of defense is to defeat the enemy's attack and gain the initiative for offensive operations. Defensive operations are conducted to identify or create enemy weaknesses that allow for the opportunity to begin offensive operations. Defensive operations are

conducted to achieve one or more of the following:

- Destroy the enemy.
- Weaken enemy forces as a prelude to the offense.
- Cause an enemy attack to fail.
- Gain time.
- Concentrate forces elsewhere.
- Control key or decisive terrain.
- Retain terrain.

THREAT IN THE OFFENSE

During defensive operations, friendly forces are the most vulnerable to the full spectrum of threat aerial platforms. The enemy will attempt to use aerial platforms to monitor friendly forces for targeting.

The number one challenge to the Avenger platoon will be to deny the enemy's use of RISTA air assets. We can expect the enemy to use UAVs, rotary-wing aircraft, and possibly fixed-wing aircraft to determine locations of friendly artillery, command and control, ADA assets, logistical sites, and troop concentration areas. Once these sites are located, we can expect threat forces to disrupt or destroy these sites with the use of artillery and rocket fire, air attacks, and air insertion.

Artillery and rocket attacks will be the enemy's preferred weapons against US forces and air defense assets. These systems are usually numerous, inexpensive, survivable,

and highly effective. UAVs will be employed to provide targeting data during this phase of the operation. UAVs are extremely effective in this role due to their small size, low radar cross section, and standoff capability. Rotary- and fixed-wing attacks are less likely during this phase due to the low survivability of these systems. In most cases, these systems are limited to daylight operations. These attacks will be supported with preattack and postattack reconnaissance.

Threat air insertion operations will be conducted with either fixed- or rotary-wing assets and probably during the hours of limited visibility. The threat will likely conduct daytime reconnaissance of landing sites and target areas within 24 hours prior to attack. These operations will fly at low levels attempting to infiltrate into friendly rear areas.

AVENGER PLANNING CONSIDERATIONS IN THE DEFENSE

In the defense, the commander will prioritize his requirements for

air defense coverage, based on his mission analysis, IPB, and METT-T.

Priority for air defense in the defense may be to the battle positions in the main engagement area, command and control elements, or logistics assets. While most supported unit SOPs outline generic air defense coverage priorities for defensive operations, each mission will have its own specific requirements.

The Avenger platoon leader must perform a mission analysis, ensuring he understands the commander's intent and the supported unit's concept of the operation. The Avenger platoon leader must clearly understand how Avengers will contribute to the force's air defense coverage. Based on these considerations, the platoon leader will develop a coverage plan to support the defensive concept of operations.

Avenger in support of light battalions in the defense is similar to heavy units. A specific consideration for Avenger in support of light units is security against infiltration which is a constant threat to light battalions. If an air infiltration or insertion is expected, the Avenger is a key system for countering this threat, especially at night and during reduced visibility. Possible LZs will be identified during the IPB process, and the LZ denial mission must be planned and coordinated with the unit controlling the terrain. Security for Avenger fire units is critical to mission accomplishment. Defense against infiltration also includes sound noise and light

discipline and position occupation procedures (see Appendix D).

Avengers will be used in areas that maximize their significant capabilities but minimize their exposure to the direct fire fight. Avengers are most suited for early engagement of RISTA aerial platforms. In the defense, Avengers will need to initially position FUs with counterreconnaissance forces or along enemy air avenues of approach that allow the enemy surveillance of defensive positions and preparations. See the following illustration, Avenger in Defensive Counter-RISTA Role With Counterreconnaissance Force.

As the counterreconnaissance (aerial and ground) fight ends, the Avengers will reposition to counter air attacks against CSS, C², FS assets, and the most dangerous enemy air avenues of approach on the unit's flanks. Initial Avenger positions and any repositioning will require coordination. Some coordination considerations are—

- Security.
- Fire control.
- Survivability.
- Logistical support.
- Command and control.
- Sensor support.
- Land management for follow-on positions.
- Counter-RISTA versus counterair insertion missions.
- Mine and obstacle plan.

Avengers are well-suited to counter air insertions. Avenger's optics equipment, mobility, and

**AVENGER IN DEFENSIVE COUNTER-RISTA ROLE
WITH COUNTERRECONNAISSANCE FORCE**

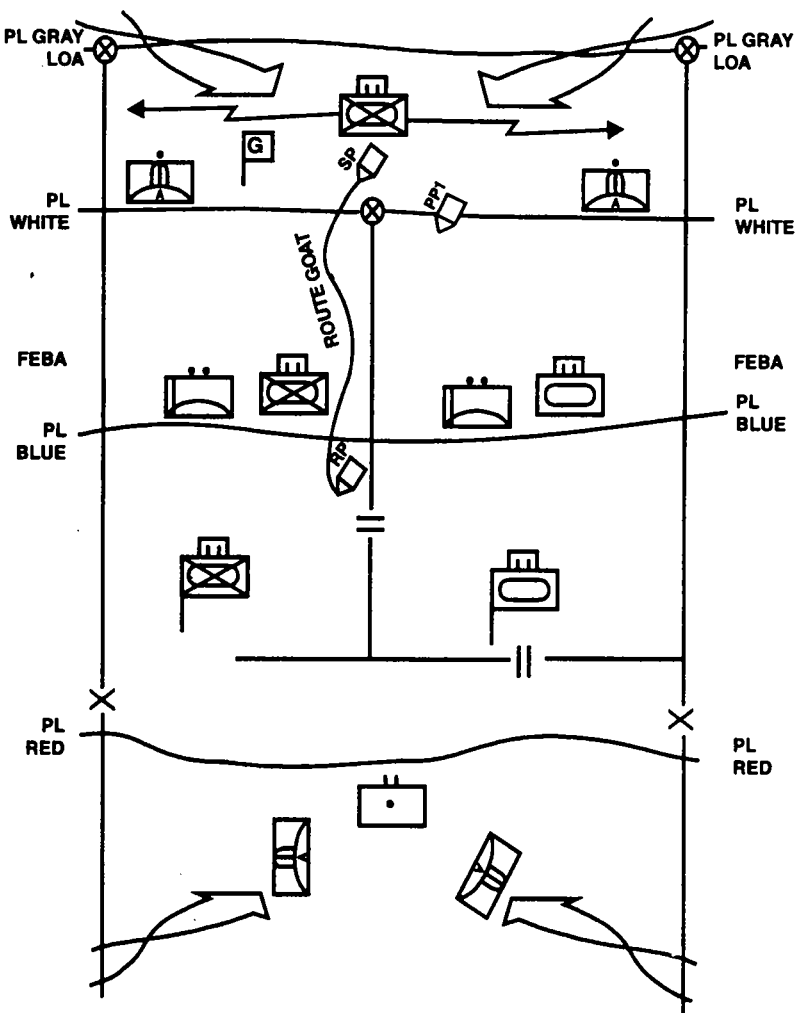

shoot-on-the-move capability make it the best choice for counterair insertion. Using Avenger also frees MANPADS and BSFV FUs to continue preparing defensive positions in and around battle positions.

Actual positioning of vehicles should be based on the air IPB, the commander's priorities for the air defense, and the location of the supported unit's assets. Vehicles should be positioned approximately 3,000 meters apart or as METT-T dictates. In the defense, Avengers may be prioritized for engineer effort and dug in to maximize survivability. The .50-caliber machine gun should be used in self-defense against ground targets.

AVENGER COVERAGE IN A DEFENSE IN SECTOR

In a defense in sector, priority is based on the supported commander's intent and METT-T. Commanders designate priorities for air defense coverage. Maneuver forces, command and control elements, and logistics nodes are normally among priorities identified for air defense coverage.

Avengers may provide overwatch for reserve forces. Avenger sections protecting reserve forces must be aware when friendly reserves are committed; they will most likely receive the brunt of the enemy air attack. Avengers will not occupy positions that expose FUs to direct fire. Avengers will provide air defense as the reserve force moves, and BSFV or MANPADS will protect the force as it occupies its

If Avengers are tasked to provide coverage for the task force reserves, they should be positioned along identified enemy air avenues of approach that influence the task force reserves' initial positions, as well as routes to their defensive or attack-by-tire positions.

The platoon leader's decision support template will result in an air defense artillery plan that synchronizes his operations with the supported commander's concept of the operation. Planning and troop-leading procedures must occur as early as possible to allow maximum preparation time. Once the basic plan is established, reconnaissance and rehearsals are key to an effective defense.

defensive positions. Close coordination between BSFV and MANPADS FUs is critical.

A task force which is part of a brigade level defense in sector may be given a series of battle positions in support of a specific engagement area within a brigade sector. This type of defensive mission is more restrictive than a defense in sector. The Avenger section or squad will not normally be within battle positions during direct fire engagements, but it can provide or augment air defense during battle position preparation and provide air defense to C², FS, and CSS assets.

The Avenger platoon leader uses the air IPB to identify the location of expected air avenues of approach. He plans his defense to mass fires on these avenues.

DEFENSE OF A STRONG POINT

The mission to create and defend a strong point implies retention of terrain with the purpose of stopping or directing enemy formations. Strong points can be used in conjunction with battle positions to maximize effectiveness. The construction of strong points involves a considerable engineer effort and an extensive amount of time, equipment, and materials. Once constructed, all positions must allow massed fires from two or more units.

A battalion task force establishes a strong point with all units within the strong point perimeter.

Positions are mutually supporting and allow massed fires from at least two units on any target area. Avenues that cannot be covered by fire are kept under observation.

In a strong point defense, ADA systems must be positioned within the strong point and oriented on the most likely air avenues of approach. METT-T and OCOKA must be used to maximize effectiveness of all air defense weapon systems. Plans must still be flexible enough to adjust and synchronize against any air threat. See the Strong Point Defense illustration below.

STRONG POINT DEFENSE

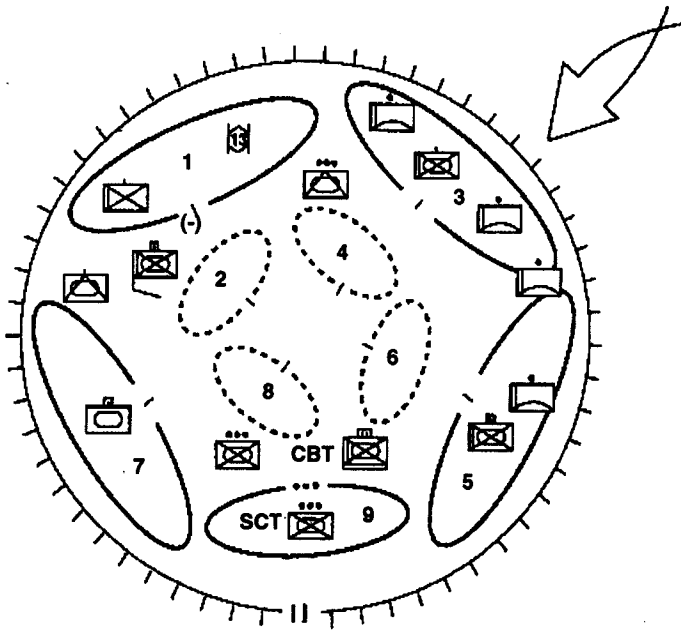

COUNTERATTACK

Counterattacks are conducted to block a penetration, to attack through forces to seize terrain, or to attack enemy forces from the flank or rear. Counterattacks are conducted by fire or maneuver forces and supported by AD. A counterattack must develop quickly to surprise the enemy before he has time to consolidate and react.

A task force conducts a counterattack against an attacking force.

The enemy attack is initially blunted in sector, causing a loss of momentum. The brigade commander's guidance is to counterattack the enemy's flank. The task force commander repositions his forces to support the counterattack.

Normally in a counterattack, some ADA systems will travel with the counterattack forces to protect them from enemy aerial platforms. See the Task Force Counterattack illustration.

TASK FORCE COUNTERATTACK

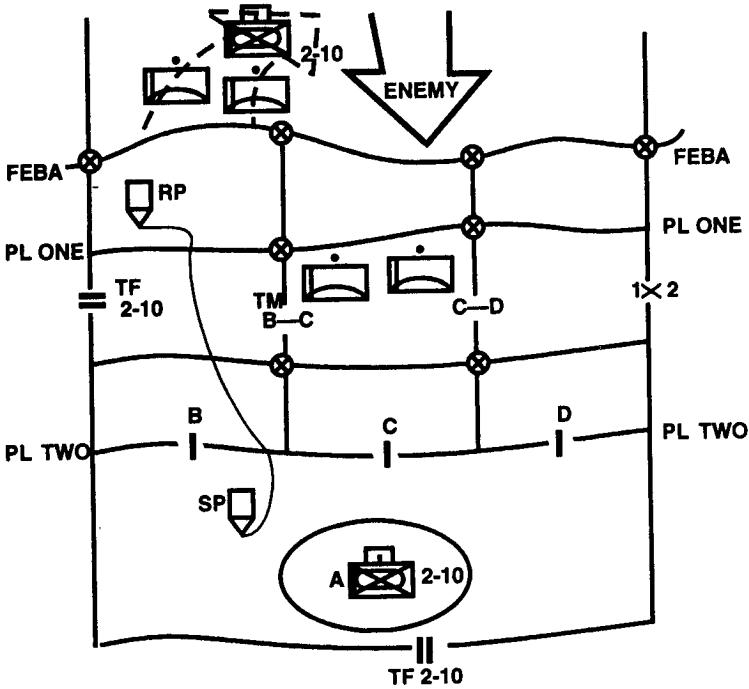

PERIMETER DEFENSE

A perimeter defense protects the force from all directions. A task force organizes a perimeter defense to provide self-protection. A perimeter is established to hold critical terrain in areas where the defense is not tied in with adjacent units. A perimeter defense may also be used to defend from a strong point. A perimeter is normally formed when a unit has been passed and isolated by the enemy and must defend in place.

A battalion task force organizes a defensive perimeter to hold a critical piece of terrain for future operations. The TF may defend with three teams in sector and one in reserve. It defends with scouts in the primary direction of the enemy attack and listening posts or observation posts in all directions.

The platoon leader uses the air IPB to determine the most likely air avenue of approach. Avenger units cover the most likely air avenue of approach but are rarely positioned outside the perimeter. The commander and platoon leaders must conduct detailed planning to ensure systems are integrated and positioned to quickly mass against the air threat. Avenger squads will cover assigned PTLs. See the Defending a Perimeter illustration.

BSFVs are best suited for strong point defense, counterattack, and perimeter defense. Avenger's involvement in these operations will most likely be augmenting DS ADA or providing air defense to priority battlefield functional areas (BFAs) in support of a task force.

DEFENDING A PERIMETER

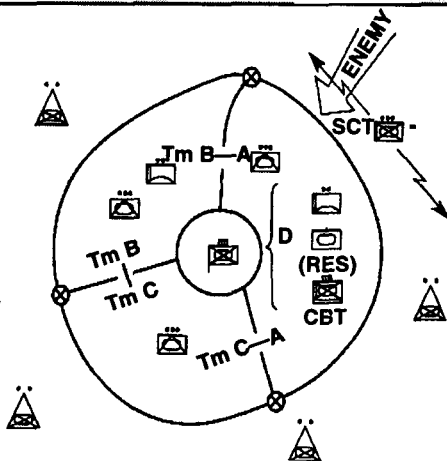

RECONNAISSANCE OPERATIONS

Reconnaissance is a mission undertaken to obtain information by either visual observation or other detection methods about the activities and resources of an enemy, or the meteorologic, hydrographic, or geologic characteristics of a particular area. Reconnaissance is a focused collection effort and is performed prior to or during other combat operations. Cavalry is the corps or division commander's principal reconnaissance organization. Cavalry combines mounted, dismounted,

and aerial techniques to accomplish its mission. Reconnaissance involves two methods. The stealth method avoids physical contact with the enemy and gathers information quietly, deliberately, and usually dismounted. The second method is aggressive reconnaissance, fighting for information as necessary, but avoiding decisive engagement. This method may be less stealthy and may proceed at a faster pace. The three forms of reconnaissance are route, zone, and area.

AVENGER IN RECONNAISSANCE OPERATIONS

Avenger platoons will provide air defense during reconnaissance operations. The Avenger's unique shoot-on-the-move capability makes it a great asset for this type of mission. The primary consideration for Avenger leaders to consider is the method of reconnaissance. If stealth is desired, is the commander willing to risk detection by engaging aerial platforms? The Avenger counter-RISTA employment methods discussed in Chapter 3 are applicable to the forms of reconnaissance, since denying the enemy information of our own reconnaissance efforts will be most important. Avengers should be positioned to maximize early engagement along routes, at choke points, and at obstacles within a zone. Avengers

will also be used to provide air defense to aviation assets, FARPs, and fire support and logistical assets. The likelihood of contact and general enemy uncertainty in the zone reconnaissance inhibits the use of the Avenger within company, team, and or troop areas of operation. Keeping the Avenger out of direct fire danger is crucial. Countering aerial surveillance and countering the air attack danger to the security force flanks is a mission most suited for the Avenger platoon. Detailed air IPB and preplanned positions throughout a zone and area or along a route that considers all obstacles and choke points will ensure adequate Avenger air defense as well as platoon command and control.

SECURITY OPERATIONS

Security operations obtain information about the enemy and provide reaction time, maneuver space, and protection to the main body. Security operations are characterized by aggressive reconnaissance to reduce terrain and enemy unknowns, gain and maintain contact with the enemy to ensure continuous information, and provide early and accurate information to the protected force. Security operations are categorized

by the degree of security provided and the amount of combat power required to perform the mission. Security operations include screen, guard, and cover. Cavalry troops screen while ACR squadrons perform guard and cover. Covering force operations are normally an ACR mission. Separate brigades or task-organized brigades may perform cover as well.

AVENGER IN SECURITY OPERATIONS

Avenger's involvement in security operations should focus on the main body rather than force protection for the security force. If counter-RISTA is a priority, Avenger will find itself in security forces. Generally speaking, if the mission is to deny the enemy reconnaissance, then Avenger will find itself heavily involved in counter-RISTA with the security force, and force protection will be a lesser priority. Reinforcing ADA from the corps is normally with a FAAD battery. The corps FAAD battalion is Avenger, therefore Avenger's involvement in security operations is likely. During screen missions, Avenger should be positioned to counter RISTA aerial platforms

for the main body. The integrated screening force ADA assets (BSFV and or MANPADS) will provide the force protection. Once again, keeping the Avenger from direct fire range is key. A flexible ADA plan with preplanned positions throughout the screened sector and based on the air IPB will deny the enemy observation of the main body. The screen force will rely heavily on BSFV and or MANPADS ADA for force protection as well as passive and combined arms air defense (CAAD). Guard missions may not require as many fire units since the AO is smaller than a screen, but the Avenger considerations for guard and cover missions are the same.

COVERING FORCE OPERATIONS

A covering force is a self-contained force that maintains

surveillance, provides early warning to the main body, impedes and

harasses the enemy with supporting indirect fires, and destroys enemy reconnaissance capability. A covering force may be offensive or defensive in nature.

Covering force operations are normally an ACR mission, but divisions may be assigned a corps covering force mission. The division will normally assign a brigade to conduct the covering

force mission. Covering force actions are characterized by speed and aggressiveness, by developing situations rapidly and with strength, by unhesitating commitment of reserves to eliminate enemy resistance and by keeping the enemy off balance. Every action is directed to ensuring the uninterrupted movement of the main force.

AVENGER IN COVERING FORCE OPERATIONS

Avenger in covering force operations is similar to Avenger in security operations where the focus should be on the main body rather than the covering force itself. Since every action is directed towards the

main body, Avenger employment should consider counter-RISTA, then force protection for the main force. The covering force will depend on BSFV and or MANPADS for its force protection.

CHAPTER 5 OTHER OPERATIONS

This chapter addresses other types of operations and the peculiarities associated with the tactical employment of air defense artillery units in support of these operations. Other tactical operations encompass a wide range of special purpose operations used routinely during offensive and defensive operations. They may be a part of a larger operation, or in some cases, performed alone. These operations may require augmentation by specialized equipment and personnel with special skills from brigade or above. The basic principles and guidelines for the employment of Avenger weapon systems do not change when ADA is supporting other combat operations.

RETROGRADE OPERATIONS

Retrograde operations are conducted to economize forces, maintain the freedom to maneuver, or to avoid decisive combat. Brigades use retrograde operations to gain time,

deceive the enemy, disengage, shorten lines of communications, or eliminate exposed flanks. The three types of retrograde operations are described next.

CONTENTS

	Page
Retrograde Operations	5-0
Encircled Forces	5-5
Linkup Operations	5-7
Defile Operations	5-8
Relief in Place	5-11
Passage of Lines	5-12

DELAY OPERATIONS

The intent of delay operations is to trade space for time, inflict maximum damage on the enemy, and avoid decisive engagement. Delays consist of a variety of subordinate unit missions ranging from attacking and conducting ambushes to defending and conducting feints. The delay creates time to support other battlefield events, such as allowing reserves to reposition. A TF will conduct a delay as part of—

- The covering force operation for defending or withdrawing forces.
- The advance guard or covering force operation when meeting superior forces.
- An economy-of-force operation to fix or contain an enemy

attack on a low-priority avenue of approach.

- A deception operation to support a counterattack.

The delay is conducted using successive alternate positions. Air defense artillery units accompany and provide coverage to maneuver units in the delaying forces. Avengers involved in delays will not be exposed to the effects of direct fire weapon systems. The Avenger platoon leader must synchronize occupying a succession of alternate positions within all of the events in a delay. This close timing ensures air defense weapon systems are in position to protect the movement of the delaying forces. See the Tactical Delay illustration on the next page.

TACTICAL DELAY

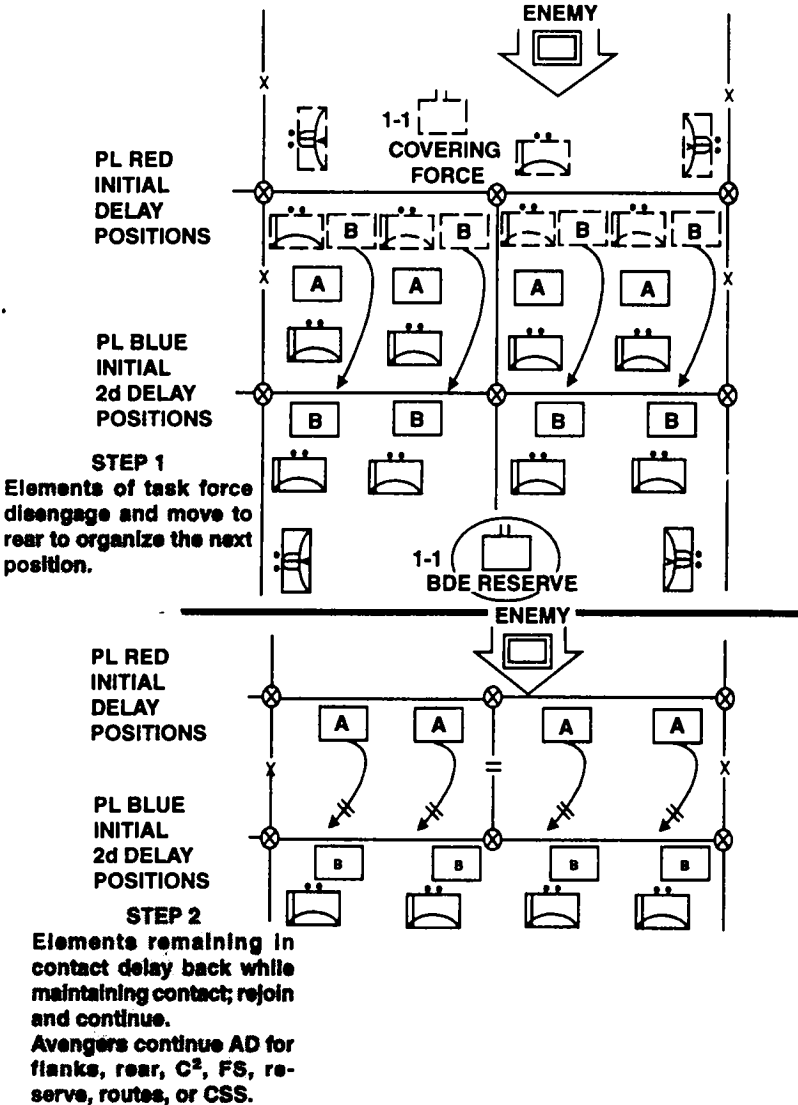

WITHDRAWAL

A withdrawal is conducted to move a unit from combat, adjust defensive positions, or relocate the force. A withdrawal may be executed at anytime, by any size force, or during any type of operation. Preferably, a withdrawal is made while a unit is not under heavy enemy pressure.

Task forces normally conduct withdrawals using a covering force and a main body. If the TF is conducting a withdrawal as part of a brigade or division force, the larger unit may provide a covering force to help the TF break contact.

Air defense artillery weapon systems supporting forward maneuver units in a withdrawal must be positioned to provide air defense protection as they are breaking contact. Air defense artillery weapon systems may be positioned along withdrawal routes or deployed with the withdrawing force. See the Air Defense Artillery During ATF Withdrawal illustration. The air defense artillery platoon leader must coordinate with adjacent air defense artillery units to determine who has coverage responsibility.

AIR DEFENSE ARTILLERY DURING ATF WITHDRAWAL

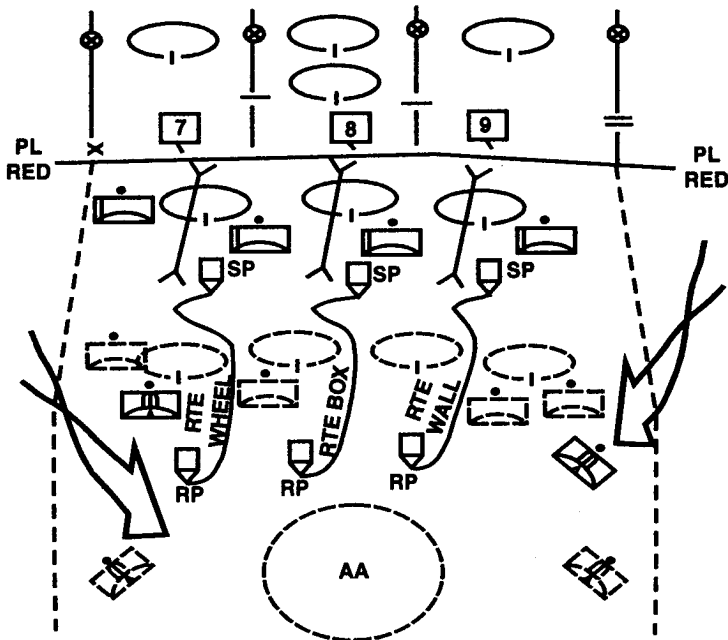

RETIREMENT

A retirement is an orderly move to the rear by an element not in contact with the enemy. The TF conducts a tactical or administrative move to the rear along multiple routes. Security is essential: advance, flank, and rear guards are employed. Retiring units may travel in tactical columns or they

may travel in convoy formations, increasing their vulnerability to enemy air attack.

Since retiring units travel in tactical road marches or administrative convoys, Avenger will be integrated into convoys. See the Air Defense Artillery Supporting a Retrograde Operation illustration.

AIR DEFENSE ARTILLERY SUPPORTING A RETROGRADE OPERATION

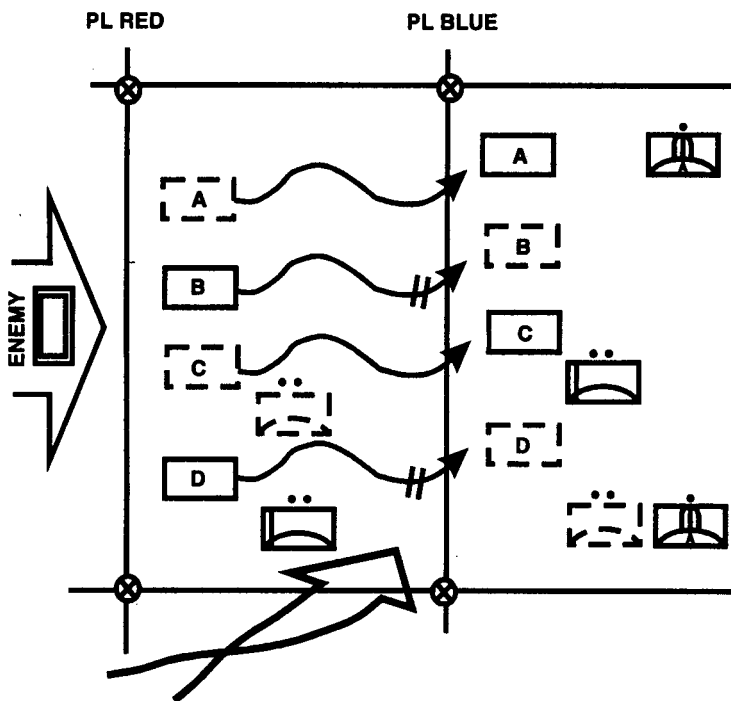

CONSIDERATIONS

All retrograde operations are difficult and inherently risky. To succeed, they must be well-organized and executed. A retrograde operation requires the following five specific elements.

Leadership and Morale

Soldiers must not perceive a move to the rear as a defeat. Leaders must maintain morale. Withdrawals must be conducted in a tightly controlled manner. Leaders must keep soldiers informed. Leaders must be present and set the example to maintain the soldiers' confidence.

Reconnaissance, Intelligence, Surveillance, and Target Acquisition

As combat power is echeloned to the rear, the RISTA threat increases. Air defense artillery assets must maintain vigilance to defeat the enemy air threat. During retrograde operations, air assaults and air insertions are likely.

Mobility

Mobility for air defense artillery forces must be maintained. Retrograde operations are fluid in nature, and air defense assets must maintain the agility to adjust coverage throughout the operation.

Deception

Deception enhances security of moving units and surprise by denying friendly unit dispositions to the enemy. The proper use of deception causes indecision and delay in enemy actions. Deception is aided by taking maximum advantage of darkness and other limited visibility conditions. Infiltration techniques are used to cover the relocation of units and material. Visual, electronic, acoustical, and thermal decoys can greatly enhance deception.

Conserve Combat Power

It is imperative for the commander to conserve the combat power of his unit during the retrograde operation. Future operations may depend on the use of this combat power.

ENCIRCLED FORCES

Due to battlefield mobility and the nonlinear nature of the battlefield, there will be situations where forces become encircled or bypassed. Regardless of the operation, units may be cut off from other friendly forces either by design or due to rapidly changing situations. Whether defending

strong points, retaining key terrain, conducting attacks, or holding the shoulder of friendly or enemy penetrations, units face the possibility of encirclement. Encirclement occurs when a ground force has all of its ground routes of evacuation and reinforcement cut off by the enemy.

Forces face encirclement most often when enemy forces bypass defending units or when advancing units are cut off by an enemy counterattack. The most important consideration of encircled forces is the continuation of their mission. The encircled force commander must attempt to establish communications with his higher commander. In the absence of communications, however, he must act on his initiative within the intent of the higher commander to maintain the integrity of his fighting force. Encircled forces have several options. They can—

- Defend until relieved.
- Conduct a breakout toward friendly forces.
- Attack and conduct small unit harassment operations (guerilla warfare operations) to reduce enemy units from the main attack.
- Attack rear echelon enemy forces and installations to disrupt their operations.

MANEUVER COMMANDER RESPONSIBILITIES

The senior maneuver commander within the encirclement assumes control of all forces. He informs his superior of the situation and simultaneously begins to accomplish the following tasks:

- Reestablish a chain of command.
- Establish a viable defense.
- Establish a reserve.
- Organize fire support.
- Reorganize logistics.
- Establish security.

- Reestablish communications, if interrupted.
- Continue the defense.
- Maintain morale.

DEFENDING ENCIRCLED POSITIONS

Encircled forces may elect to stay in position and defend encircled positions. Important considerations in a decision to stay and fight are—

- Mission and commander's intent.
- Possibility of exfiltration from the encircled positions toward friendly forces.
- Good defensive terrain.
- Available reinforcement or relief.
- Availability of the necessary combat support to sustain the operation.
- The enemy's mobility.
- Motivation and discipline of troops.

BREAKOUT FROM ENCIRCLEMENT

Breakout operations are planned, organized, and executed before the enemy has time to react. Commanders considering the breakout option face the critical demand of time. Encircled forces have to act before the enemy decides on a course of action and begins to contain or destroy the encircled forces.

The attack to break out of an encirclement differs from other attacks only in that a simultaneous defense in other areas of the perimeter is maintained. To achieve a

breakout, the commander accomplishes the following tasks:

- Deceive the enemy as to time and place of the breakout attack.
- Identify and exploit gaps or weaknesses in the encircling force.
- Exploit darkness and limited visibility.
- Organize the forces for the breakout.
- Concentrate combat power at the breakout point.
- Coordinate with supporting attacks.

EXFILTRATION

If success of a breakout attack appears questionable and a relief operation is not planned, the least preferred option to preserve a portion of the force is through organized exfiltration. It can distract the enemy from his main effort

and produce intelligence for the main force.

The encircled forces are organized into small groups under small unit leaders and exfiltrated during periods of limited visibility through gaps in the encircling forces. Equipment which cannot be taken is left behind and destroyed.

AIR DEFENSE CONSIDERATIONS

Air defense units that are caught with encircled forces will continue their air defense mission. They should orient their fires to the likely air avenue of approach. If a breakout force is planned, the air defense units should mass their fires to cover the force during the breakout. Air defense artillery leaders must rigidly enforce fire control measures to conserve ammunition.

LINKUP OPERATIONS

Linkup operations are conducted to join two friendly forces. Both forces may be moving toward one another, or one may be stationary or encircled. Linkup operations may be conducted in a variety of circumstances. They are most often conducted to—

- Complete the encirclement of an enemy force.
- Assist the breakout of an encircled friendly force.
- Join an attacking force with a force inserted in the enemy rear (for example, an airborne, air assault, or infiltration force).

For a TF linkup operation, the

TF TOC establishes the command relationship between forces and the responsibilities of each. It also establishes control measures, such as linkup points, boundaries between converging forces, fire support coordination lines, restrictive fire lines, coordinated fire lines, and other measures to control maneuver and fires. Control measures may be adjusted during the operation to provide for freedom of action as well as positive control.

When one of the units involved is stationary, linkup points are usually located where the moving force's routes arrive at the location

of the stationary force's security elements. Alternate linkup points are also designated since enemy action may interfere with linkup at primary points. Stationary forces assist in the linkup by opening lanes in minefield, breaching or removing selected obstacles, furnishing guides, and designating assembly areas.

Linkup between two moving units is a difficult operation. Primary and alternate linkup points for two moving forces are established on boundaries where the two forces are expected to converge. As joining units move closer to one another, the need for positive control to avoid firing on one another must be coordinated by commanders to ensure that the enemy does not escape between the two forces. Leading elements of each force must be on a common radio net.

During linkup operations, air defense considerations must focus on air defense protection of friendly forces. There must be lateral communications between the air defense officers from both forces to assure an integrated and synchronized air defense effort.

The battery TOC may assist in communications or synchronization during linkup operations. The air defense plan should incorporate the air defense priorities of both supported force commanders, the total number of air defense weapon systems available, and the factors of METT-T. Platoon and fire unit responsibilities must be planned, coordinated, and rehearsed. The supported force and parent unit must be informed of the disposition of air defense elements throughout the operation. Failure to synchronize the air defense plan may result in fire units with the same priorities and leave the task force vulnerable to air attack on unprotected air avenues of approach.

During linkup operations, particularly with airborne or air assault units, the rules of engagement become extremely important. The brigade A²C² element must ensure timely dissemination of information and coordination so that ADA units do not engage friendly aerial platforms that may be supporting the airborne or air assault units.

DEFILE OPERATIONS

A defile operation is a critical and vulnerable mission. Because of terrain considerations, maneuver forces must mass into relatively small areas. The benefits of dispersion are lost and vulnerability to air attack increases. Air defense artillery units

must provide protection to the force conducting the operation.

PASSAGE POINTS AND CHOKES

Defile drills through choke points or passage points area routine, yet a critical phase of offensive operations. They

pose particular challenges to the Avenger platoon. Because of terrain or mission constraints, maneuver units canalize forces into relatively narrow areas, usually moving in column formation. The benefits of dispersion are lost and vulnerability to enemy indirect and direct aerial fires increases. Often, minimum cover and concealment exists at choke points. Targeting choke points is a common procedure. Choke points can be natural or man-made and can vary from bridges and mountain passes to passages through minefield or between obstacles. Passage lanes are choke points because they canalize the force while it moves through a stationary force. The ADO must therefore conduct a delayed analysis of the route of march for potential choke points and likely air avenues of approach. This process will enable him to focus air defense fires on targeted areas of interest where he can destroy attacking forces.

Pre-positioned coverage and hasty coverage from the march are techniques that exist for providing air defense coverage at choke points. The Avenger platoon may use either of these techniques or a combination of both. Avenger must be integrated throughout the formation so that even in the mountains, likely air avenues of approach are protected at all times.

RIVER-CROSSING OVERVIEWS

River crossings are conducted to maintain the momentum of an

operation. The approach to the water obstacle is made on a broad front whenever possible. Hasty crossings using captured bridges or fords are the products of rapid offensive action. Detailed planning ensures that fire support and crossing means are available with the following tactical concepts in mind. *Assault forces* lead, making the initial assault of the obstacle and continuing the advance from the far side. *Follow-on forces* provide overwatch, direct and indirect fire support, crossing site security, and support assistance to the assault.

The Avenger platoon must be prepared to support river crossings by either hasty or deliberate operations. In either case, considerations are similar to providing air defense of a breaching operation. The only difference is that the hasty crossing is characterized by maintained momentum and rapid transition or continuation of the attack. The ADO must keep this in mind during planning to minimize disruption of air defense coverage, allowing maneuver forces continued forward momentum. Massed friendly forces in a small area provide the enemy a target-rich environment. Factors of METT-T and the IPB must be continuously monitored to determine whether the crossing will be opposed or unopposed. Planning and continuous coordination are critical to successfully provide air defense for the force.

The Avenger platoon leader must consider the following as he

prepares his units to defend and negotiate obstacles:

- Enemy air avenues of approach.
- Positioned local security.
- A thorough reconnaissance.
- Most suitable method for crossing obstacles.
- Near- and far-side support.
- Vehicles, personnel, equipment, and entrance and exit points.
- Continuing operations once the crossing has been completed.
- Effects obscuring will have on weapon systems' visual acquisition and identification of targets.
- Protection of crossing assets.
- Key terrain on the far side that enemy aerial platforms may use for hide and standoff engagement positions.

- Resupply plan throughout the operation.

The Avenger platoon leader must ensure that he knows what is happening during all phases of the operation. He must be flexible and aggressive in his planning to ensure air defense protection is provided during the entire crossing operation. See the River Crossing illustration.

RIVER-CROSSING OPERATIONS

The objective in a river crossing is to project combat power on the far side of the river quickly to maintain momentum. River crossings are either hasty, deliberate, or retrograde.

River-crossing operations may be conducted to continue an attack

as part of a delay or withdrawal. River crossings can also be used to concentrate forces for another offensive or defensive operation.

A battalion TF normally crosses a significant river obstacle as part of a brigade-, division-, or corps-level operation.

A strong and well-planned AD is necessary for a successful river-crossing operation. A mix of ADA weapons (BSFV and Avenger) may be employed in mass to protect crossing sites. Avenger's involvement in river-crossing operations will depend on the echelon of the unit conducting the river crossing.

RIVER CROSSING

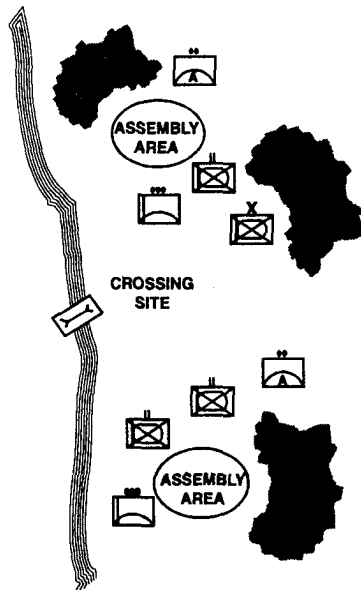

In brigade-level river crossings, Avengers will be held in general support. The primary consideration for Avenger employment is occupying effective ADA positions out of the effects of direct fire systems. Avenger will be employed to ensure the continuous air defense of the crossing site (a critical choke point) and critical commander's priorities such as C², engineer support, FS, and CSS. As the crossing site is secured and combat power is building on the far side, BSFVs will displace to the far side to continue with the maneuver forces. As the brigade consolidates combat power on the far side, Avengers will move to the far side.

Battalion- and or TF-level river crossings will normally be hasty river crossings. Avengers will reinforce BSFV or provide

GS-R air defense and will occupy crossing site positions only after the site is secure from direct fire systems' effects. Once the far side is secure, Avengers should be employed to maximize early engagement but should maintain mutual support. If RISTA UAVs are a threat, and risk is accepted, the predominant fire employment guideline will be overlapping fires. Gaps between fire units may also be considered as depicted in the Avenger in Counter-RISTA Role During Movement illustration in Chapter 3. The Avenger can be integrated into column formations to maximize mutual support when overlapping fires cannot be accomplished due to dispersion distances within columns. Air IPB is critical to success (see the River Crossing illustration on the previous page).

RELIEF IN PLACE

Relief in place is an operation in which a unit is replaced in combat by another unit. Responsibilities for the combat mission and the assigned sector or zone of action are assumed by the incoming unit. A relief in place can occur during offensive or defensive operations.

The primary purpose for a relief in place is to maintain the combat effectiveness of committed elements. A relief in place may be conducted to—

- Give a unit a break from combat when it has taken heavy losses.

- Relieve the stress of prolonged operations in adverse weather or terrain.

- Replace a unit that requires medical treatment or decontamination as a result of combat losses or exposure to chemical or nuclear munitions.

- Conform to a larger tactical plan.

During the relief in place of a unit, the Avenger platoon supporting the relieving force will coordinate with the replaced force air defense artillery element. CPs should collocate to improve coordination. This coordination will

cover, but not be limited to, air IPB, rules of engagement, current air activity, present fire unit positions, A²C² information, the operations plan, logistics, and communications. Air defense protection must be planned for all forces during all phases of the relief in place.

As the relieving Avenger sections arrive, they will move out to designated positions selected by the platoon leader. The sections emplace and are integrated into the present unit's air defense coverage. This relief can be sequential (one fire unit at a time) or simultaneous (all incoming fire units emplace, then outgoing fire units displace). If the relieved unit is in prepared positions, the sequential method is very effective. Transfer of range cards and prepositioned ammo can be affected. In any case, the outgoing command post retains control until the relief is complete. Relief operations most often occur during limited visibility to mask the operation. This factor must be considered because it complicates the operation in terms of time and ease.

This overlap of air defense protection will aid in ensuring good coverage. Once the replaced

unit's systems have departed, the platoon leader will assume complete control of the mission. The platoon leader must do the following before assuming control:

- Relieve air defense artillery systems in place; do not degrade air defense.

- Coordinate with the departing unit about the enemy situation, specifically the departing unit's assessment of air avenues of approach.

- Recommend air defense priorities to the supported commander.

- Determine the air threat and enemy capabilities.

- Evaluate air avenues of approach.

- Confirm the present WCS and ADW.

- Confirm hostile criteria and ROE.

- Confirm the locations of friendly AD units.

- Position fire units according to the supported commander's AD priorities.

- Establish communications with early warning sensors in the area.

- Obtain and disseminate airspace control measures.

PASSAGE OF LINES

A passage of lines is conducted to allow a moving unit to pass through a stationary unit. It can be conducted as part of offensive,

defensive, or retrograde operations. A passage of lines may be designated as a forward passage or rearward passage. A passage

of lines is rarely a primary mission; it is usually performed incidental to a mission.

In planning a passage of lines, air defense is absolutely essential. Whether passing forward or to the rear, the moving unit will be forced to move slower and often in some type of column formation during the passage. Congestion in assembly areas after the passage and the linear nature of the movement presents a lucrative target to hostile air assets. As a result, air defense must be coordinated with the stationary unit. In most cases, the stationary supported force will be able to protect the passing force, allowing the passing force's supporting air defense assets to move

with them. However, if the passing force requires static air defense coverage, the terrain will have to be coordinated with the supported stationary force.

The stationary force Avenger platoon may be reinforced or augmented with additional ADA elements to provide air defense protection for the passage of lines. It is imperative that the moving force ADA platoon leader coordinate with the stationary force ADA platoon leader for the position of all air defense elements supporting the passage of lines. Furthermore, he must develop and coordinate an air defense plan in the event the moving force becomes static.

CHAPTER 6 LOGISTICS

This chapter discusses LOGPAC support for the Avenger platoon. The Avenger platoon receives logistics from the supported unit or the battery headquarters. The platoon leader and platoon sergeant should ensure they conduct detailed and timely coordination to logistically support the tactical situation. Logistics, or lack of it, may determine the success or failure of combat operations. The Avenger platoon should be armed, fueled, and repaired as far forward as the tactical situation permits. Forward support is accomplished through logistics packages (LOGPACs).

LOGISTICS FUNCTIONAL OVERVIEW

Logistics operations in combat and combat support battalions are normally organized into support trains. Support elements from the companies and the battalion headquarters displace from the combat elements into either field trains or

combat trains. The support and supplies available vary greatly between the combat trains and the field trains.

Battalion combat trains carry the minimum amounts of supplies and equipment needed to sustain the force for short periods of time.

CONTENTS

	Page
Logistics Functional Overview	6-0
LOGPAC Operations by the Supported Force	6-2
LOGPAC Operations by the Battery Headquarters	6-4
Cross-Leveling	6-5
Aerial Resupply	6-5
Personnel Services	6-6
Replacement Operations	6-7
Health Services Support	6-7

Combat trains will be positioned where they can quickly provide essential support to fighting forces, usually between the company team area and the brigade support area (BSA). Combat trains can provide battlefield recovery, maintenance, medical services, and some Class III and V support.

Field trains will consist of the remainder of the battalion combat service support (CSS) element. Field trains for all task forces and battalions operating in the brigade area are located in the forward part of the BSA. The BSA will also consist of the brigade trains, forward area support teams, and other combat support and combat units.

LOGPACs are organized and put together at the field trains. They usually include Class I, III, V, medical, and Avenger peculiar items. The platoon leader and platoon sergeant are responsible for planning and executing an effective CSS system for the platoon. CSS functions such as supply, maintenance, field services, personnel services, and health services must also be considered during the planning phase.

The Avenger platoon leader conducts logistics planning. The Avenger platoon logistics plan is implemented by the platoon sergeant. The platoon sergeant

consolidates information provided by the section leaders and requests support from the supported unit or battery. Routine and recurring CSS operations should be addressed in unit SOPs.

The platoon sergeant is the maintenance coordinator for the ADA platoon and assists the platoon leader in all logistical aspects. The PSG and ADO must synchronize their efforts to ensure that the PSG maintains situational awareness and that the ADO keeps him well informed. The battle captain concept can assist in both tasks (see Chapter 1). The PSG is chief advisor to the ADO on all maintenance matters and provides maintenance quality control for all squad maintenance. He closely supervises squads during maintenance and logistics activities and ensures high preparedness standards through precombat inspections (see Appendix D).

The PSG supervises precombat checks, recovery operations, initial battle damage assessments, and the application of field expedients. He completes maintenance and logistical forms and records and must know readiness reporting requirements and the general capabilities of the battery, battalion, and or supported unit's maintenance teams and logistics support system. He must also understand the forward

maintenance concept (recovery and repair as far forward as possible) and the area support concept.

If the Avenger is employed and deployed to a divisional rear or corps rear, it will be supported by the parent unit, if time and distance permits. Otherwise, Avenger platoons will be supplied on an area support by a designated CSB. Area support means that DS supply and maintenance relationship in effect are determined by the location of

the units requiring support. For more information see FM 63-3. The ADA brigade and or battalion S4's job is to provide the Avenger battalion and battery commander with information, and to work through support relationship issues. The Avenger platoon leader will establish the support relationship through the supporting maneuver S4 and or directly with a FSB or CSB support operations section.

LOGPAC OPERATIONS BY THE SUPPORTED FORCE

Joint integration of logistics is crucial to unity of effort. The Avenger platoon leader cannot rest on the notion that logistics is the responsibility of the supported force; he must take the responsibility to ensure that essential Avenger parts are part of the LOGPACs moved forward under the control of the supported force. Support for the Avenger platoon is discussed in this chapter.

SUPPORTED FORCE

LOGPAC operations at the supported force level are formed by companies and moved forward under the control of the support platoon leader who normally organizes a convoy for movement of all LOGPACs under his control. In emergencies, he dispatches unit LOGPACs individually. The convoy may contain additional vehicles, such as a maintenance vehicle with Class IX to move to the

unit maintenance collection point (UMCP), or additional ammunition and fuel for the combat trains. The LOGPACs move along the main supply route (MSR) to a logistics release point (LRP), where the company's first sergeant or a unit guide takes control of the company LOGPAC. After the company has been resupplied, the company first sergeant informs his supply sergeant of requirements for the next LOGPAC. The supply sergeant collects outgoing mail and equipment for movement to the rear. The LOGPAC then returns to the LRP, where it joins the rest of the supported force's LOGPACs for return to the field trains (see the LOGPAC Operations by Supported Unit illustration).

AVENGER PLATOON

Anytime the Avenger platoon has a support relationship of direct support, the basic principles of

LOGPAC OPERATIONS BY SUPPORTED UNIT

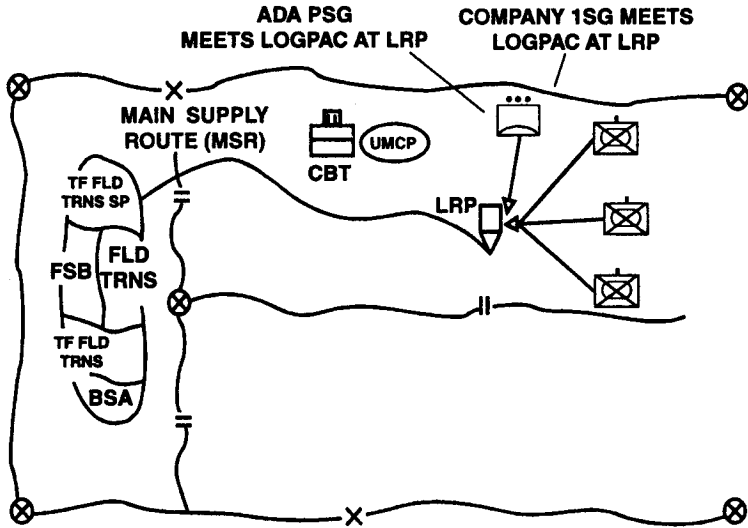

LOGPAC operations by the supported unit will apply. If the platoon is reinforcing another ADA platoon, it should follow the procedure established for the ADA platoon that is being reinforced. It must integrate into the planning and preparation of the supported force's LOGPAC operations.

The platoon should coordinate with the supported force constantly to ensure the platoon's LOGPAC has the items required, is formed at the field trains, and moved forward to the LRP. The Avenger platoon sergeant must ensure that supplies, equipment, and personnel replacements which are peculiar to the ADA mission (for example, Stinger

missiles and ADA personnel) are coordinated with the support platoon leader or supported unit S4 and S1. When the LOGPAC reaches the LRP, the Avenger platoon sergeant or a designated representative will take control of the platoon's LOGPAC.

Maintenance and evacuation of damaged vehicles will be coordinated with ADA battery or the supported force which is closest. The location of UMCPs should be available and briefed to platoon personnel. When the supported force has not responded to a request for support in sufficient time, the platoon leader should notify the supported force commander and his battery commander.

Evacuation of wounded personnel has to be coordinated with the supported force. This is time-sensitive and generally beyond the capability of the Avenger platoon. This requires the Avenger platoon to be knowledgeable of the supported

force's SOP on evacuation procedures. The platoon must be informed of locations for casualty collection points. When the tactical situation allows, organic platoon vehicles may be used to evacuate the wounded.

LOGPAC OPERATIONS BY THE BATTERY HEADQUARTERS

LOGPAC operations by the battery headquarters follow the same procedures as supported force LOGPAC operations with the exception of having different, key players. The major difference is that the platoon will normally be operating in terrain which is "owned" by a larger fighting force. The support relationship will likely be general support or general support-reinforcing. In this situation, the battery may provide the support.

The battery support vehicles are maintained at the battery trains where they are loaded with the necessary supplies. The battery first sergeant, with the help of the battery supply sergeant, form the LOGPACs for each Avenger platoon based upon prior coordination. The first sergeant moves the LOGPACs forward along the established MSR to a designated LRP. When MSRs and LRPs are located within the area of operations of another unit, the platoon leader or platoon sergeant may be required to coordinate for the use of MSRs or LRPs with the unit occupying the area. When the LOGPACs arrive at the LRP, the Avenger platoon sergeant or a

designated representative will take control of the platoon's LOGPAC. Once the platoon has been resupplied, the vehicle returns to the LRP, and the platoon sergeant gives his requests to the battery first sergeant for the next LOGPAC.

LRP locations are determined either by the first sergeant or a designated representative (such as the battery XO). LRPs are established based on the tactical situation. It is often useful or necessary to coordinate for the use of MSRs or LRPs which have already been established. The LRP should be close to where the platoons are employed and easy to locate. The MSR, LRP, UMCP, and trains locations should be included on the operations overlay. The LOGPAC convoy arrival time at the LRP and length of time it remains are normally established by the SOP.

The first sergeant or responsible battery representative remains at the LRP as long as the LOGPAC vehicles are in the platoon area. He should ensure that the LOGPAC release and return take place efficiently. To assist in the coordination for the next

LOGPAC, the following must be considered:

- Changes in logistical requirements reflecting any last-minute changes in task organizations.
- Reports on personnel, logistics, and maintenance from the platoon sergeants.
- First-hand updates on the tactical situation and logistical status.
- Delivery, receipt, and distribution of mail.

The battery maintenance personnel monitor and ensure the Avenger platoons are being supported in

LOGPAC operations. Contact teams will be integrated into the LOGPAC convoys when required by the platoons. Contact teams will be moved from LRPs by the platoon sergeants. If it is necessary to evacuate a vehicle, the recovery asset will move the vehicle to the battery UMCP.

Evacuation of wounded personnel has to be coordinated and planned in detail. Evacuation of wounded personnel should be by the most expeditious means possible. The means to evacuate personnel will be based on the unit SOP and the current tactical situation.

CROSS-LEVELING

Cross-leveling is not a technique of resupply but a way to make supplies last longer. It is the distribution of supplies evenly throughout the platoon. It is done automatically by section leaders and platoon sergeants in the assembly areas and after every action. Cross-leveling usually takes place between section and team members but is also used between sections and platoons. It is done for repair parts and all classes of supply. In

some cases, supplies may be shifted in the platoon to increase combat potential. For example, if a section is preparing for movement but is short on ammunition and water, they may acquire or draw these items from the other sections remaining in position. These sections would, in turn, be resupplied by the normal resupply system. Cross-leveling between platoons must be approved by the battery headquarters.

AERIAL RESUPPLY

Supplies can be delivered by Air Force aircraft or by Army helicopters. The airdrop of supplies poses less risk to the aircraft than air landing, but can result in the supplies being widely dispersed and possibly lost. This increases the time needed for recovery and resupply.

Airlanding is the quickest and most accurate way to deliver supplies, but it poses an additional risk to the aircraft and may attract enemy fires to the resupply point. Unless conducting the resupply in an area under friendly control and away from direct enemy observation, the resupply

should be conducted away from the main unit in an area that can be defended for a short time. Security is required during the entire resupply action. Leaders receiving aerial resupply must be aware of several considerations as discussed in the following paragraphs.

LANDING AND PICKUP ZONES

The size of the landing zone depends on the number of aircraft, height of obstructions on the landing zones (LZ), wind direction, and velocity. The LZ or pickup zone (PZ) is marked by smoke, lights, or panels for identification. The ground and air elements should have radio contact with each other. When identifying the LZ, the aircraft pilot is required to describe the panel code letter, smoke, or other visual marking (see FM 90-4).

AIRDROPS

Air Force airdrop of supplies may be high level (2,500 feet or above) or low level. The minimum size for a drop zone (DZ) is normally 500 yards by 500 yards. This

accommodates one airdrop bundle. Prior coordination is required to determine ground markings and DZ location. An Air Force combat control team may be necessary to provide a ground communications link with Air Force aircraft. An Army pathfinder, or pathfinder experienced leader, provides the ground communications link for Army aircraft. Aerial delivery of supplies is not a precise method of delivery (refer to FMs 57-38 and 90-26).

AIRLAND AND SLINGLOAD

Delivery of supplies by slingload and airland, using Army helicopters, requires the same consideration when selecting an LZ. Security of the area is critical due to aircraft vulnerability during landing, lift-off, or hovering. Other considerations include rapid unloading of supplies and moving them from the LZ before the enemy can interdict the operation with fires. Slingloads require practice to prepare, airlift, and deliver. After the aircraft departs, clear the area of slings, platforms, cans, and cardboard.

PERSONNEL SERVICES

Personnel services consist of strength accounting, casualty reporting, replacement procedures, maintenance, personnel actions, and awards.

According to local SOP, a strength accounting report is sent to

battery headquarters detailing platoon strength by officer, enlisted, and attached personnel. At higher echelons, these reports are used to determine which units receive priority when replacement troops arrive.

When a casualty occurs, DA Form 1156 is filled out for each casualty as soon as the tactical situation permits. This report is processed through administrative/logistics (ADMIN/LOG) channels. This information is used

to inform the soldier's next of kin and to provide a statistical base for analysis of friendly or enemy activity. The platoon leader should be prepared to write a letter for the commander's signature to be sent to the soldier's next of kin.

REPLACEMENT OPERATIONS

Integrating replacements into a platoon is important. A new soldier arriving on the battlefield may be scared and disoriented as well as unfamiliar with local SOPs and the theater of operations. The platoon leader and platoon sergeant should welcome him to the unit, interview him, and introduce him to his section leader and team leader. The section leader introduces him to the team and briefs him on his duty position, and assigns him an

experienced "buddy" to "look out" for him. This in-briefing should cover recent section and platoon activities, current activities, future activities, and enemy activity. Furthermore, this in-briefing should reinforce the fact that he is part of a good unit with a proud heritage (*esprit de corps*). The soldier should be told about important SOPs and special information concerning the area of operations.

HEALTH SERVICES SUPPORT

At platoon level, health services support consists of three things: prevention, treatment, and evacuation of casualties. Emphasis is placed on prevention since soldiers may become combat ineffective due to nonbattle injuries or disease as often as due to combat. These casualties may be eliminated by understanding and applying the principles of field hygiene and prevention of weather-related injuries. Leaders have the responsibility to monitor the overall condition of their soldiers (refer to FM 21-10).

The leader must be prepared to treat and evacuate casualties. The treatment of serious casualties consists

primarily of stabilizing the soldier until he can be evacuated to the nearest medical aid station.

Casualties are treated and may be evacuated directly from the platoon by vehicle or helicopter. If evacuated by vehicle, they are taken to the supported unit casualty collection point designated in the OPORD. If evacuated by helicopter, they are taken to the rear area to receive medical assistance.

Unit SOPs and OPORDs address casualty evacuation in detail. They cover the duties and responsibilities of key personnel, rank methods of evacuation, and establish procedures for retrieving and safeguarding the

FM 44-44

weapons, ammunition, and equipment of casualties.

In war, leaders must be prepared to treat and evacuate casualties. The combat lifesaver program enhances the platoon's ability to provide immediate medical attention to casualties until evacuated to the nearest casualty collection point. The unit must identify and train selected team members as combat lifesavers. The goal is to have one combat lifesaver in each Avenger section.

APPENDIX A

AIR DEFENSE ORDERS AND ANNEXES

To execute a plan, the platoon leader must be able to organize his thoughts and convey them in a concise and informative manner to his subordinates. To do this, the platoon leader must have a thorough understanding of the different types of orders and annexes he will receive and issue.

WARNING ORDER

A warning order (WARNO) gives subordinate units advance notice of a contemplated action or order to follow. The purpose is to initiate the troop-leading procedures of subordinate units.

DETAIL INFORMATION

The amount of detail included in a warning order is dependent upon the time available, the means of communications available, and the information necessary for subordinate leaders. As more information becomes available, additional warning orders should be issued. Warning

orders are normally oral orders but may be brief written messages.

ESSENTIAL INFORMATION

The essential information required in a WARNO is as follows:

- “Warning order” stated so that addressees will recognize that orders follow.
- Address to whom the WARNO pertains.
- A brief description of the enemy and friendly situation.
- Time and nature of the operation. Mission or probable mission and time.

CONTENTS

	Page
Warning Order	A-1
Operation Order	A-2
Fragmentary Order	A-5
Air Defense Annex	A-5

- Earliest time to move.
- Time and place for OPOD issuance.
- Special instructions including any details of early coordination, rehearsals, critical event time lines, special equipment requirements, attachments, et cetera.
- Acknowledgement that the WARNO has been received and understood. See the Sample WARNO illustration.

SAMPLE WARNO

WARNING ORDER

1st platoon moves night of 5-6 Aug to assembly area Pinto (VIC YR1016); prepare to advance early 7 Aug to provide AD for river crossing over Warta River. Road movement plan and OPOD to be issued at 051300Z August at grid YQ985105.

OPERATION ORDER

To carry out the plan, the platoon leader must be able to convey his thoughts in a concise and informative manner. The Army's operation order (OPOD) format standardizes the content and organization of information essential to clarity and execution of the order.

Leaders at all levels must practice preparing and presenting OPODs. The time used will be time well-spent. Normally, at platoon level, the

order will be oral or an annotated graphic overlay.

The five-paragraph OPOD tailored for an ADA platoon should contain the following information:

- Situation.
- Mission.
- Execution.
- Service Support.
- Command and Signal.

The Air Defense Operation Order Format illustration gives the format for an OPOD.

AIR DEFENSE OPERATION ORDER FORMAT

(Classification)

1. SITUATION

Information of the overall situation essential to a section leader's understanding of the current situation.

a. **Enemy Forces (weather, terrain, identification, location, activity, strength, level of training, and suspected enemy tactics).**

- (1) **Ground forces.**
- (2) **Air forces.**
- (3) **Capabilities.**
 - **UAV RISTA type of operations.**
 - **Weapons free zones for UAVs.**
 - **Cruise missile flight profile.**

Note: Air IPB should be briefed at this time to subordinates.

AIR DEFENSE OPERATION ORDER FORMAT (CONTINUED)

b. **Friendly Forces and Commander's Intent** (mission of next higher headquarters; locations and planned actions of units on left, right, front, and rear; fire support available; and the mission of any adjacent or supplementary air defense, if applicable).

- (1) ADA forces.
- (2) Supported forces.

c. **Attachments and Detachments** (units attached to or detached from your unit by higher headquarters and effective time).

d. **Weather and Terrain.**

- (1) Beginning morning nautical twilight (BMNT).
- (2) End (of) evening nautical twilight (EENT).
- (3) Moonrise and moonset times.
- (4) Percent illumination.
- (5) Weather forecast for next 24 hours or period of OPORD, including the low and chance of precipitation.
- (6) Terrain information concerning vegetation, type of terrain features, trafficability of roads, cross-country movement, and local water features.

2. MISSION

The mission includes who, what, when, why, and where. Include the command and support relationship and priority.

3. EXECUTION

This paragraph contains the platoon leader's visualization of the execution of an operation from start to completion.

a. **Platoon leader's intent for the operation.** This should include the purpose, method, and the desired end state. The platoon leader may include the battery commander's intent and or the supported unit commander's intent.

b. **Concept of operation for support of maneuver forces, stationary asset, convoy, et cetera.** This should include the overall plan and missions of the platoon.

- (1) Scheme of maneuver relevant to the supported force.
- (2) Fire support target reference points, target list, and family of scatterable mines (FASCAM) locations.
- (3) Coordinates of priority asset, if applicable.

c. **Subunit Missions** (using the platoon execution matrix, assign mission to each organic and attached section, or team to include the priority of protection for each unit).

d. **Coordinating instructions.**

- (1) Time of leader's reconnaissance, departure, and return.
- (2) Weapon control status and air defense warnings.
- (3) Rallying points and actions at rally points.
- (4) Actions at supported unit's objective or upon enemy contact to include disengagement criteria.

AIR DEFENSE OPERATION ORDER FORMAT (CONTINUED)

(5) Any information concerning two or more fire units not covered by SOP.

(6) Rehearsals, backbriefs, and inspections.

(7) Formations to be used by the platoon or supported unit.

(8) Crew endurance plan.

(9) Rules of engagement.

(10) Hostile criteria.

(11) Mission-oriented protection posture (MOPP).

(12) Actions on objectives.

(13) Passive and active AD (combined arms for air defense)

Instructions to pass on to the supported unit.

(14) Platoon timeline (SP, RP, stand-to, NLT defend time, et cetera).

4. SERVICE SUPPORT

This paragraph contains CSS instructions for support of the operation.

a. Rations, POL, and water.

b. Ammunition control, ASP location, and resupply plan.

c. Maintenance: motors, ADA systems, and communications (contact teams).

d. Uniform and equipment.

e. Method of handling sick, wounded, and EPWs (supported unit coordination).

5. COMMAND AND SIGNAL

This paragraph contains instructions relative to command and to the operation of common communications equipment.

a. Command.

(1) Chain of command and locations.

(2) Locations of headquarters CPs and alternate CPs (battalion, battery, platoon, and supported unit headquarters).

b. Signal.

(1) Supported unit frequency.

(2) Convoy frequency (if applicable).

(3) Challenge, password, signals, and codewords.

(4) Early warning frequency; IFF code book number.

(5) Listening silence instructions.

(6) Artillery or FIST element frequency.

(7) Alternate frequencies.

(8) Antijamming procedures (if not addressed in SOP).

Notes:

1. Prior to the briefing, orient personnel with maps (if time permits construct a sandtable). Provide personnel with strip maps and graphic overlays posted on maps.

2. Conduct a backbrief at the end of the OPORD to ensure personnel understand the order.

3. Establish rehearsal location and date-time group.

(Classification)

FRAGMENTARY ORDER

A fragmentary order (FRAGO) is an order which presents material extracted from a more detailed order or which changes a previous order. Like warning orders, FRAGOs are usually brief oral or written messages. A mission order is one form of fragmentary order

which provides experienced leaders with the essentials of an order; that is, their mission or a change to a previously issued mission. FRAGOs may be oral, written, or graphic. In all instances, they are brief. See the FRAGO illustration.

AIR DEFENSE ANNEX

An annex is an integral part of an order which deals with one aspect of an operation. Its purpose is to keep the basic text of an order short. Annexes allow the distribution of certain information to key players in the task force.

Annexes include—

- Details that amplify the basic order (operations overlay and intelligence instructions).

- Combat support instructions (ADA, fire support, and engineer).
- CSS instructions (service support overlay and traffic circulation and control instructions).
- Any other information or directions required to amplify the order.

Many times, the platoon leader supporting a specific unit will be required to write the AD annex to the

FRAGO

Reference: OPOD 7

Map series V661, sheet 7061, edition 1, scale 1:50,000.

Task Organization: 2d platoon GS to brigade eff 141400ZJan.

1. SITUATION Tank battalion delaying advance of TF 1-6.

2. MISSION No change.

3. EXECUTION
 1st section LOC TS456835, PTL 6400 mls.
 2d section LOC TS481814, PTL 1600 mls.
 3d section LOC TS454783, PTL 3100 mls.

4. SERVICE SUPPORT No change.

5. COMMAND AND SIGNAL Platoon CP currently at TS454814.
 Acknowledge.

supported unit's OPORD. Annexes can be attached to the order or distributed separately. Unless there is good reason to the contrary, each

copy of an order is issued complete with all annexes. See the Sample ADA Annex Format illustration.

SAMPLE ADA ANNEX FORMAT

(Classification)

Copy no __ of __ copies
Issuing headquarters
Place of Issue
Date-time group
Message reference no.

ANNEX __ (AIR DEFENSE) TO OPERATION ORDER NO __

References: maps, charts, and other relevant documents.
Time zone used throughout the order.

1. SITUATION

Items of information affecting air defense support not included in paragraph 1 of the operation order or which need to be expanded.

a. Enemy Forces.

- (1) Reference to Intelligence annex, if applicable.
- (2) Enemy air capabilities.

b. Friendly Forces.

- (1) Outline higher headquarters plan.
- (2) Outline higher and adjacent unit AD plans.
- (3) Note additional AD resources supporting the unit.

c. Attachments and Detachments. Air defense resources attached and detached to include effective times.

2. MISSION

A clear, concise statement of the air defense mission.

3. EXECUTION

SAMPLE ADA ANNEX FORMAT (CONTINUED)

a. Commander's Intent.

b. Concept of Operation. A brief statement of the air defense operation to be carried out, to include air defense priorities.

c. Tasks to subordinate ADA units.

d. Coordinating instructions.

(1) Instructions applicable for two or more subordinate units.

(2) Reference to supporting appendixes not referenced elsewhere in the annex.

(3) WCS, ROE, and ADW.

4. SERVICE SUPPORT

5. COMMAND AND SIGNAL

Acknowledgement instructions.

**Last name of commander
Rank**

**Authentication
Appendixes
Distribution**

(Classification)

This sample of an execution matrix is only a guide to aid the platoon leader in his planning process. An execution matrix may also be used as an ADA annex. This sample matrix simply takes the place of paragraph three in this text, except for coordinating instructions. There is no specified format for this matrix; however, the following steps may be used to construct one.

Step 1. Establish the basic matrix, with all major elements of the platoon listed across the top.

Step 2. List the stages or phases of the operation down the left side of the matrix. When planning, you may elect to leave blank rows for "Be Prepared" and "On Order" missions.

Step 3. Fill in the blocks with brief descriptions of the actions required for each stage or phase as they apply to the element on the top of the matrix. Use abbreviations where possible, and you may have to make a legend to assist in abbreviating. If a unit's task

is the same from one stage or phase to the next, list it only the first time, do not recopy it. If additional instructions are required, such as PTL azimuth, sector of search degrees, directed movement techniques, position in a formation, or air avenue of approach

orientations, draw a diagonal line through the box. List the actions required in the upper left-hand portion. List the additional instructions in the lower right-hand portion of the divided box. See the Execution Matrices illustration.

EXECUTION MATRICES

TAA	NK 123456	East 1/2 of TAA AAAs 1 & 3	West 1/2 of TAA AAAs 2 & 3	R to 1/A/441 ADA
Link Up		GS to 1/5 FA NLT 251900 Nov AAAs 2 & 4	APs 1 & 2 AAAs 2 & 3	NK 145456 NLT 251900 Nov
LD	Bde TAC		APs 3 & 4 AAAs 4 & 5	
Breach	NK 1234504	APs 3 & 4 AAAs 4 & 5	APs 5 & 6 AAAs 5 & 6	
Obj Goat	Bde TAC	APs 7 & 8 AAAs 5 & 6	APs 9 & 10 AAAs 5 & 6	Return to Pit control APs 11 & 12 AAAs 5 & 6

Legend: AAA = air avenue of approach; AP = Avenger position;
R = reinforcing

APPENDIX B

COMBINED ARMS FOR AIR DEFENSE

In a conflict, threat aerial platforms may operate over the entire battlefield with the potential to attack any friendly unit or force. Army units operate under the protection of ADA units. However, for close protection and self-defense, these forces also depend on their own passive and active air defense measures. Every member of the combined arms team must be capable of firing at attacking air threat platforms. Individual and crew-served weapons provide a significant defense against aerial threats.

PASSIVE AIR DEFENSE

Passive air defense includes all measures used to prevent attack by threat aerial platforms except engagement-by fire. The effectiveness of enemy air is greatly reduced when units take full advantage of terrain for cover and concealment. The strict enforcement of communications security reduces the enemy's ability to pinpoint friendly units. This is particularly important for C³I nodes. If the situation allows, units should—

- Travel by covered and concealed routes when moving.
- If moving when enemy air attacks, turn vehicles 90 degrees away from the direction of attack (the attack is normally parallel to the movement of the convoy) and seek cover and concealment. This quickly gets vehicles out of the line of fire.
 - Wipe out track marks after moving into position.
 - Occupy positions which offer natural cover and concealment when stopped. Camouflage vehicles that are exposed to enemy observation.

CONTENTS

Passive Air Defense	Page B-1
Active Air Defense	B-2

- Dig in and camouflage dismounted positions. Use engineer assets if available.
- Disperse vehicles as much as possible. This makes detection and engagement difficult.
- Cover windshields, headlights, and canopies of vehicles to retard glare, making detection difficult.
- Require air guards on each vehicle and at each position and rotate them.

- Establish an air attack warning system. Include both visual and audible signals. Ensure warning system is included in supported unit OPORD (usually coordinating instructions).

- Ensure unit SOP includes passive air defense measures tailored to the unit. The SOP must be practiced during unit training.

ACTIVE AIR DEFENSE

Active air defense is direct action taken to destroy or reduce the effectiveness of an enemy air attack. Techniques of engaging aircraft for non-ADA systems are summarized below.

distance. Aiming points for slow-and fast-moving aerial targets using the football field technique for estimating lead distance are shown in the following three illustrations, on pages B-3 and B-4.

ENGAGEMENT PRINCIPLES

While the decision to fire is made at the lowest level and is based on the leader's judgment of the situation, the techniques used in delivering fire are standard. Volume fire is the key to effective small arms fire against hostile aerial platforms. Every weapon must be used to engage the target. The goal is to mass a high volume of sustained small arms fire in the target's flight path with the intention of destroying the aerial platform when it flies into the fire. Each fire unit and individual must select an aiming point in front of the target and fire at that point. This method uses the football field technique for estimating lead

Small Arms

(M16, M60, M249, and M2)

Fighting back is active air defense, but should not be undertaken as a one-on-one activity (one soldier, acting independently, against one aircraft). Rather, it is a coordinated group response undertaken either spontaneously or under command using proper engagement techniques.

Precision is not important. A coordinated high volume of fire will get results. Fire should be delivered on command and not at the option of the individual. This will ensure a controlled, high-volume engagement. See the Aiming Points illustration on page B-5.

CROSSING TARGETS

SLOW TARGET LEAD ANGLE

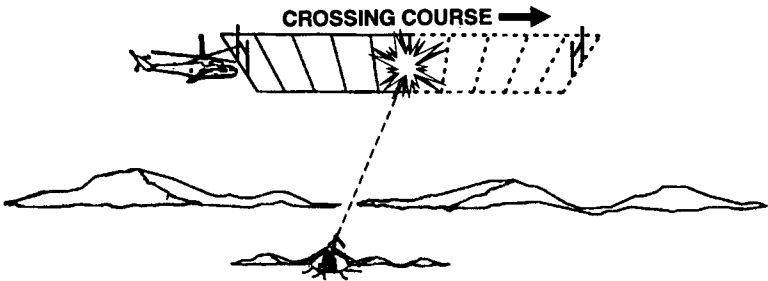

Lead slow targets (usually helicopters and propeller-driven aircraft) by 1/2 football field.

FAST TARGET LEAD ANGLE

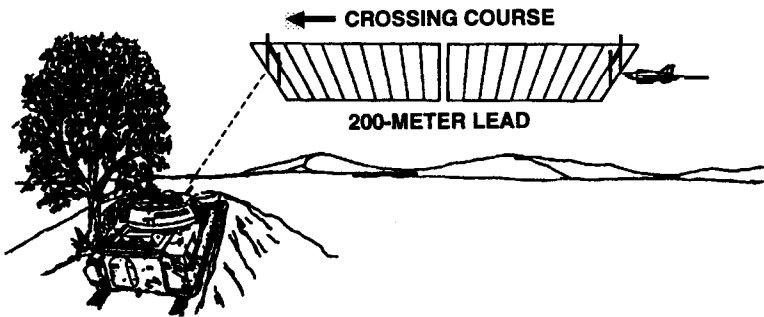

Lead fast targets by 2 football fields.

FORWARD APPROACHING TARGET

DIRECT ATTACK

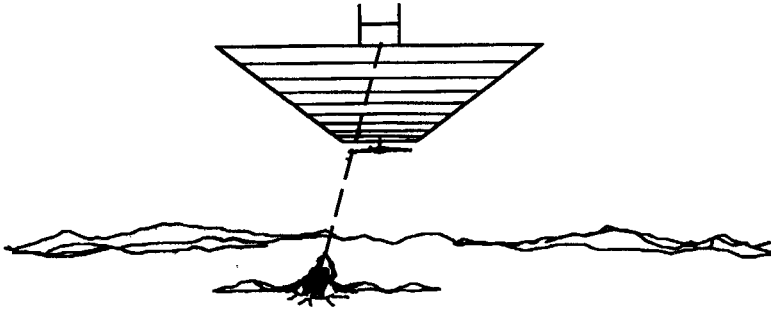

OVERHEAD TARGET

TWO
FOOTBALL
FIELDS

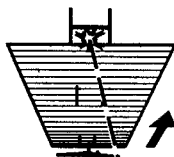

OVERHEAD
COURSE

 AIMING POINTS

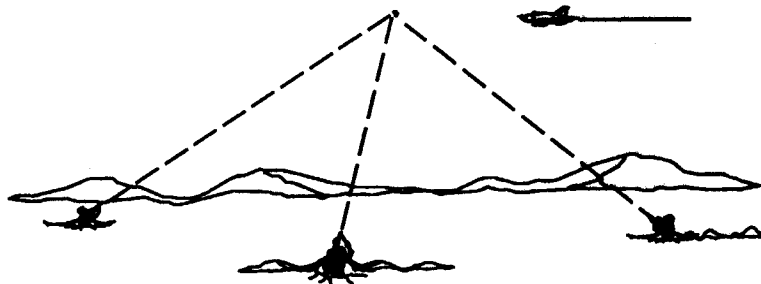
MASSED SMALL ARMS FIRE

**Firing Positions For
Small Arms**

A supine position is the proper firing position for the engagement of aerial platforms. This means the soldier is lying on his back, aiming his weapon into the air. Soldiers should seek some kind of cover and concealment no matter how small. If in an individual fighting position, fire from a supported standing position. If not in an individual fighting position, look for a tree, a large rock, or something to help support the weapon and provide protection.

The M249 gunner will also fire from a protected position if possible. He can hold the weapon up or use a support for his arms and the weapon. In an emergency, another soldier can act as a hasty firing support.

**VEHICLE-MOUNTED
WEAPONS (ENGAGEMENT
TECHNIQUES)**

See Appendix K, The Engagement Systems.

APPENDIX C
**RECONNAISSANCE, SELECTION,
AND OCCUPATION OF POSITION**

This appendix presents the reconnaissance, selection, and occupation of position (RSOP) requirements and their applications. The procedures for RSOP have been developed to ease the rapid, orderly, and safe movement of ADA systems on the battlefield.

Avenger platoons displace frequently, whether deployed in forward or rear areas. They move to support the maneuver force plan in response to mission changes. They also move to enhance survivability. The RSOP must be part of a unit SOP, be clearly understood, and be practiced repeatedly by all members of the platoon.

METHODS OF RECONNAISSANCE

Reconnaissance is the thorough examination of terrain to determine its suitability for accomplishment of the mission. The three methods of reconnoitering are: map, aerial, and ground.

MAP RECONNAISSANCE

A study and analysis of a tactical map will provide an appreciation of the terrain, and show

the best route to the selected location. A map reconnaissance—

- Precedes all other methods. A map should always be available for the area of operations.
- Allows quick examination of large areas. This is faster than other reconnaissance methods.
- Cannot determine current conditions of the area. The map may be dated and provide an

CONTENTS

	Page
Methods of Renaissance	C-0
Reconnaissance, Selection, and Occupation of Position Sequence	C-2

inaccurate representation of the area.

- Ensures the most security. A map reconnaissance can be conducted in a secured location.

AERIAL RECONNAISSANCE

If an aircraft is available, the commander or the RSOP officer can see the terrain. An aerial reconnaissance—

- Provides the fastest way to see the terrain.

- Is limited by aircraft availability, weather, and light conditions.

- Is still an imperfect reconnaissance. Fields of fire, ground conditions, and local threat cannot be determined unless the aircraft lands.

- Is less secure than a map reconnaissance. Aircraft activity in an area exposes soldiers to threat activity and also reveals an interest in a particular area.

GROUND RECONNAISSANCE

A ground reconnaissance is an on-site examination of the terrain. A commander or RSOP officer should note that a ground reconnaissance—

- Is the most accurate and desirable type of reconnaissance. The route can be evaluated for

trafficability, obstacles, choke points, and key terrain. Firing positions, fields of fire, and air avenues of approach can be analyzed for planning finalization.

- Is time-consuming. Covering the distances over potential routes and checking alternate positions takes time. The ground reconnaissance is the slowest method of reconnaissance.

- Is dangerous. The small reconnaissance party could be subjected to threat observation en route or at the objective area.

If ground or aerial reconnaissance cannot be performed, engineer terrain teams may be able to provide necessary information. Plans can be made for the reconnaissance to include routes, RPs, assembly points, and assembly times for the reconnaissance party. If time is limited and the unit must move before the reconnaissance party returns, road guard positions are selected and soldiers necessary for these tasks are included in the RSOP party.

Actual inspection of the chosen routes and positions on the ground is desirable to confirm selections made from the map, or to make necessary adjustments in plans.

RECONNAISSANCE, SELECTION, AND OCCUPATION OF POSITION SEQUENCE

The RSOP party will normally be led by a squad leader. The sequence of actions for conducting the RSOP are summarized in the following paragraphs.

RECEIVE THE ORDER

The commander meets with his key personnel, passes on the basic order and briefs his key personnel on the new mission. The commander's briefing includes information on the purpose of the operation, routes, road clearance times, start point (SP) and release point (RP) locations, and AD operational times. Each platoon leader reviews his briefing notes, completes precombat checklists, and initiates the reverse planning sequence.

ISSUE MOVEMENT WARNING ORDER

The platoon leader returns to the assembly area, issues a movement warning order, and briefs his key personnel on the new mission.

The movement warning order can be—

- Written or verbal.
- Delivered in person.
- Passed over tactical communications nets.

The warning order must include, as a minimum, the new mission, the location of the planned area of operation, the time of release for march order, crossing the SP and RP, and assuming operational

status at the planned area of operation.

MAKE A MAP RECONNAISSANCE

This is the fastest way to conduct a reconnaissance and will always precede any other type of reconnaissance. The positions of Avengers, BSFVs, and dismounted Stinger teams are plotted on a map and represent the best locations for providing air defense protection. The platoon leader must consider the air defense employment guidelines, weather, and the factors of METT-T. Alternate positions should be identified at this time. After the weapon positions have been plotted on a map, positions for checkpoints and primary and alternate routes are selected and plotted. The platoon leader identifies a reconnaissance route by conducting a map reconnaissance to the proposed area. Positions selected by map reconnaissance must be confirmed by additional reconnaissance if the tactical situation allows.

PLAN THE GROUND RECONNAISSANCE

Reconnaissance is performed to select the best fire unit positions, march routes, SPs, RPs, checkpoints, sensor positions, and communications sites. The ADA platoon leader should coordinate with the local maneuver commander and the supported unit battalion S3 to

determine what areas maneuver units plan to occupy. Mutual agreement must be established to make the best use of the available terrain. The platoon leader selects personnel and equipment to conduct the reconnaissance with him and assigns tasks to the reconnaissance party personnel. The unit SOP will establish the normal composition and responsibilities of the party. The reconnaissance party for the platoon should consist of at least the platoon leader and one representative from each squad. The RSOP party also includes a security force.

BRIEF NEXT-IN-COMMAND— ISSUE ORDERS

After the platoon leader finalizes and coordinates the plan, he briefs his personnel covering all elements of a five-paragraph OPORD (Situation, Mission, Execution, Service Support, and Command and Signal). He identifies at least the SP and RP. His briefing and issuing of orders should include instructions on continued operations in the absence of key leaders.

CONDUCT RECONNAISSANCE AND SELECT POSITIONS

As soon as RSOP preparations are complete, the platoon leader departs with the reconnaissance party. He ensures that the selected primary route meets equipment (height, weight, and width) requirements, is

passable, and avoids possible ambush locations. He positions road guides as required. He may keep the platoon main party posted on his progress, by referencing predetermined checkpoints. As the RSOP party approaches the new location, the platoon leader checks the area. The team leader must ascertain if the tentative map-selected locations will allow immediate occupation for accomplishment of the mission. Ground reconnaissance verifies whether the terrain provides good natural concealment; has access roads for primary and alternate routes into the position; provides good observation, fields of fire, and sectors of search; and has firm ground that will support the weight of the equipment.

NBC and mine detection team leaders will check the immediate area to ensure it is free of contamination and mines. A total security plan is then placed in effect. This includes positioning automatic weapons overlooking the main avenue of approach and alternate routes into the position, and establishing other security positions around the area to preclude gaps in the perimeter. A PTL and an SOF are assigned to each squad, and communications are established with all the positions. Proposed positions plotted during the map reconnaissance should be used if possible. The team leaders will select tentative sites for the weapons and observation posts (OPs) and

confirm them with the platoon leader. The platoon leader reconnoiters the platoon area and selects the site for the platoon command post (CP). He visits each proposed weapon site, if possible, and supervises or assists the squad representative. After approving the positions, he informs the battery commander and the supported unit of the weapon and platoon CP locations.

Positions selected must be the best available for fields of fire, communications, accessibility, and survivability. He considers the following specific characteristics in selecting sites for the platoon headquarters:

- CP is centrally located with respect to fire unit positions.
- Cover and concealment are available.
- Alternate entrance and exit routes are available.
- Position is defensible against ground attack.
- Communications can be established with higher, lower, and supported units.

The following are characteristics which must be considered in selecting sites for Avenger squads:

- Primary and secondary fields of fire, and observation must be clear.
- Communications with platoon CP, other squads in the platoon, and with EW sources are available.
- Positions must be within 100 meters of plotted positions

in original defense design. If not, defense may need to be redesigned.

- Positions make maximum use of available cover and concealment to facilitate survivability.

The firing signature of the Stinger system discloses the weapon's position during each engagement; therefore, frequent shifting of position is required. Units will select primary, alternate, and supplementary positions during the ground reconnaissance. Routes into and out of these positions must be selected and prepared as necessary. The following positions are normally selected by ground reconnaissance:

- Primary position. A position from which the fire unit intends to accomplish its tactical mission.
- Alternate position. A position to which the fire unit moves when the primary position becomes untenable or unsuitable for carrying out the assigned mission. The alternate position must be far enough away to prevent its being rendered untenable by the same action that affected the primary position. The alternate position must meet all the requirements of the primary position.
- Supplementary position. A place to fight which provides the best means to accomplish a task that cannot be accomplished from the primary or alternate positions.

Care must be exercised to avoid placing positions near terrain features easily recognized from the air. Positions are more vulnerable to enemy fires once spotted near an identifiable object.

PREPARE TO OCCUPY THE POSITIONS

After the platoon leader has selected the positions, he ensures the ground guides know exactly where he wants all the vehicles and equipment emplaced. Preparation should include marking the location of each major piece of equipment (as required). Everyone at the new position is given the new challenge and password, information on any known enemy activity in the area, and the approximate arrival time, location, and order of vehicles for the main party.

MOVE THE UNIT TO THE NEW POSITIONS

The platoon leader informs the platoon sergeant of the results of his reconnaissance and relays appropriate instructions for the movement of the main body. The platoon sergeant organizes the vehicles as ordered by the platoon leader. Platoon vehicles use movement techniques dictated by the factors of METT-T and unit SOP.

OCCUPY, ORGANIZE, AND IMPROVE THE POSITIONS

The occupation of positions should be coordinated with the

supported unit to avoid mutual interference. When the platoon arrives at the position, all vehicles move off the road into the position, without halting and without closing the interval between vehicles. The unit SOP should state the requirements and the priorities for occupying positions.

When all squads have reported that they are in position and capable of providing coverage of their assigned sector, the platoon leader will report the platoon "ready for action."

Squad leaders begin improving positions as dictated by SOP or additional orders. Atypical improvement sequence may include—

- Natural camouflage. Supplement existing camouflage nets where possible with indigenous materials (branches, leaves, and snow). These materials should be from the vicinity of the squad so they will blend naturally into the surroundings.

- Individual fighting positions. Hasty positions are prepared for the team. These will be replaced by deliberate fighting positions.

- Cover. The Avenger personnel dig the vehicle in, hull down, for protection from blast, fragmentation, and small arms. Engineer support will be required in most situations, and should be requested through the supported unit.

- Alternate and supplementary positions. Work on alternate and supplementary positions is initiated as early as possible to ensure that they are available should the primary become untenable.

FM 44-44

Upon occupying the position, the platoon must provide continuous local security. Obstacles such as a hasty protective minefield provide security which blocks, disrupts, or canalizes enemy attacks. All obstacles must be coordinated with the supported unit S3 and the engineer officer. Other measures taken should also be integrated with the ground defense plan of the supported unit. Range cards should be prepared. At a minimum, range cards should indicate ranges to critical points on all likely avenues of approach, dead spaces, and likely targets (air and ground).

APPENDIX D

AVENGER PLATOON, SECTION, AND SQUAD CHECKLISTS

The checklists in this appendix are recommended for use by the Avenger platoon leader, platoon sergeant, and section or squad leaders. They are not all-inclusive; however, they are useful in most combat situations. Additions can be made to these checklists where required. If the battery SOP calls for different or more detailed procedures, the local SOP can be followed.

CONTENTS

	Page
Platoon Precombat Inspection Checklist	D-2
Platoon Leader's Planning Checklist	D-3
Platoon Sergeant Checklist	D-4
Section or Squad Leader's Briefing Checklist	D-6
Position Occupation Checklist	D-6
Platoon Coordination Checklist	D-7
Platoon Command Post Checklist	D-8
Platoon Operation Checklist	D-9

PLATOON PRECOMBAT INSPECTION CHECKLIST

Individual soldier readiness.

- 1. TA-50 inventory. _____
- 2. Assigned weapon clean and zeroed. _____
- 3. Assigned NBC mask with accessories. _____
- 4. Load-bearing equipment (LBE):
 - a. First aid pouch with dressing. _____
 - b. Canteen(s) with water. _____
 - c. Ammo pouch with magazines. _____
 - d. Decontamination kit. _____

Equipment readiness.

- 1. Publications for vehicles. _____
- 2. Logbook, dispatch, and drivers' licenses. _____
- 3. Ensure before-operation PMCS and daily operations have been completed per TMs and FMs. _____
- 4. General.
 - a. Orders and rehearsals conducted. _____
 - b. Required package products on-hand. _____
 - c. Bill present and serviceable. _____
 - d. Fuel can(s) filled. _____
 - e. Water can(s) filled. _____
 - f. Necessary maps on-hand. _____
 - g. Rations distributed. _____
 - h. Vehicles loaded by load plan. _____
 - i. Compasses on-hand. _____
 - j. All necessary manuals on-hand. _____
 - k. Flashlights. _____
- 5. Communications equipment.
 - a. All necessary (supported force, AD, et cetera) TACSOPs and SOIs on hand. _____
 - b. Radios and Intercom operational. _____
 - c. AH connectors and receptacles clean. _____
 - d. Grounding straps secure. _____
 - e. Antennas and matching units complete and serviceable. _____
 - f. Field phones present and serviceable. _____
 - g. Applicable batteries on-hand. _____
 - h. Radios complete and operational. _____
 - i. COMSEC equipment operational and programmed. _____
 - j. GPSs operational. _____
 - k. CVC helmet present and operational. _____
- 6. Fire control system.
 - a. Firing circuits operational. _____
 - b. Optics clean, operational, and present.
 - (1) Sights. _____
 - (2) Night vision device. _____

**PLATOON PRECOMBAT INSPECTION CHECKLIST
(CONTINUED)**

- (3) Binoculars. _____
- 7. Weapons. _____
 - a. All weapons clean. _____
 - b. All machine guns have spare barrels and cartridge extractor. _____
 - c. Weapons cleaning equipment on-hand. _____
 - d. Ammo basic load. _____
- 8. Safety. _____
 - a. Road crossing equipment (warning triangles, safety vest, and flashing lights). _____
 - b. Safety briefing. _____
 - c. Vehicle safety check performed. _____
 - d. First aid kits and or aid bags filled. _____

PLATOON LEADER'S PLANNING CHECKLIST

- Analyze the threat.
- 1. Aerial portion of IPB. _____
 - 2. Ground portion of IPB. _____
 - 3. Templates air indicators. NAIs and TAIs. _____
 - 4. Receive DST from battery. _____
- Analyze mission.
- 1. Does the mission focus on priority assets? _____
 - 2. Does the mission focus on supported force? _____
 - 3. Does the mission focus on counter-RISTA? _____
 - a. Early stage operations considerations:
 - (1) Convoy. _____
 - (2) Choke points. _____
 - (3) Troop and logistics concentrations. _____
 - (4) APOD and SPOD. _____
 - b. Considerations for operations.
 - (1) Passage of lines. _____
 - (2) Movement to contact. _____
 - (3) Meeting engagement. _____
 - (4) Hasty attack. _____
 - (5) Deliberate attack. _____
 - (6) River crossing and breach. _____
 - (7) Defend in sector. _____
 - (6) Defend BP and strong point. _____
 - (9) Delay. _____
 - (10) Withdrawal. _____
 - (11) Convoy. _____
 - (12) Choke points. _____

PLATOON LEADER'S PLANNING CHECKLIST (CONTINUED)

- (13) Troop and logistics concentrations. _____
- 4. Backward planning. _____
 - a. Equipment emplacement time. _____
 - b. Movement time from RP to position. _____
 - c. Convoy time. _____
 - d. SP time. _____
 - e. Briefing time to section leaders. _____
 - f. Ammunition, POL, and ration resupply plan. _____
 - g. Maintenance completion time. _____
 - h. Time necessary to set hasty defense. _____
 - i. Movement time to rally point. _____
 - j. March order time. _____
 - k. Reconnaissance time. _____
 - (1) Primary route. _____
 - (2) Alternate route. _____
 - l. Time to pass WARNO. _____
 - m. Receipt of order. _____
 - n. Rehearsal time. _____

PLATOON SERGEANT CHECKLIST

Note: The platoon sergeant should use all checklists to assist the platoon leader and to check his platoon and its leaders. This checklist focuses on command and control, planning, preparation, and execution. Certain tasks have dual application to a phase; they are identified by the phases to which they apply.

Monitor platoon operations:

- 1. Obtain, copy, and distribute graphics (maneuver, obstacle, CSS, and A²C²). _____
- 2. ADA planning. _____
- 3. Intelligence dissemination. _____
- 4. Monitor supported unit planning, preparation, and execution. _____
- 5. Advise platoon leader on statue of platoon combat power status to include personnel and sensitive items and focusing on FUs, and Classes V, III, and I. _____
- 6. Ensure EW and or FAAD C³I is operational and understood throughout platoon and supported unit. _____

Maintain situational awareness:

- 1. OPORD on-hand and understood. _____
- 2. WARNOs on-hand and understood. _____
- 3. FRAGOs on-hand and understood. _____
- 4. Platoon, battery, and supported unit scheme of _____

PLATOON SERGEANT CHECKLIST (CONTINUED)

- maneuver understood by platoon. _____
 - 5. Ensure good security plan during position Occupation. _____
 - 6. Know location of battery and supported unit maintenance collection point (UMCP): current and future. _____
 - 7. Know location of battery and supported unit TOC and TAC: current and future. _____
 - 8. Know location of battery and supported unit decontamination sites: current and future. _____
 - 9. Know location of battery and supported unit casualty collection points: current and future. _____
 - 10. Know locations of sensors supporting PLT. _____
- Planning, preparation, and execution: (each task will be labeled with the stage that it applies).
- 1. Planning
 - a. Assist PL with platoon time line development and enforcement. _____
 - b. Assist PL with developing a sound platoon C² plan. _____
 - c. Ensure an argon resupply plan is in place. _____
 - 2. Planning and preparation
 - a. Ensure platoon casualty and vehicle evacuation plan is complete and rehearsed, if time allows. _____
 - b. Class IV distribution plan developed. _____
 - c. Engineer equipment usage management plan. _____
 - d. Assist platoon leader in planning and conducting all rehearsals. _____
 - e. Ensure coordination with supported unit for all classes of supply and support. _____
 - f. Ensure cross-leveling and resupply plan is in place. _____
 - 3. Preparation
 - a. Ensure supported unit scheme of maneuver A²C² measures (ACPs, SAAFRs, et cetera) and fire support coordination measures (trigger lines, TRPs, EAs, et cetera) are disseminated and understood. _____
 - b. Conduct PSG and PL PCI. _____
 - 4. Preparation and execution
 - Ensure passive AD measures are enforced. _____
 - 5. Planning, preparation, and execution
 - Maintain platoon maintenance status. _____
 - 6. Execution
 - a. Take action to correct NMC vehicles. _____
 - b. Assist PL in adjusting AD based on maintenance and or combat losses. _____
 - c. Assist PL in reporting platoon status (FU locations, combat power, engagement, and Classes V, III, and I, et cetera). _____

SECTION OR SQUAD LEADER'S BRIEFING CHECKLIST

Note: This checklist contains the minimum information the section or squad leader must receive from the platoon leader to accomplish his mission.

- Mission. _____
- Fire unit location and alternate. _____
- PTL. _____
- SOF. _____
- Route and alternate route. _____
- ADW/LADW/SOR. _____
- WCS. _____
- Hostile criteria. _____
- Platoon rally point. _____
- RP. _____
- Friendly units in AO. _____
- Platoon FRAGO/OPORD and rehearsal location and time. _____
- ROE. _____
- MOPP. _____
- EW plan _____
- A C measures in effect in the AD. _____

POSITION OCCUPATION CHECKLIST

- Does the area have the following features? _____
- Sufficient area for dispersion. _____
- Alternate exit and entrance routes. _____
- Easily defended against ground attack. _____
- Easily recognizable and known to all sections. _____
- Good communications with higher, lower, and supported units. _____
- Good observation. _____
- Reconnaissance prior to occupation. _____
- Coordination with adjacent unit prior to occupation. _____
- Area secured prior to occupation; listening post and observation post established at main entrance. _____
- NBC detection, monitoring, and survey team check the area prior to arrival. _____
- Ensure a closure report is submitted per SOP. _____
- When necessary, establish vehicle dismount point with ground guide. _____
- Place NBC alarms. _____
- Establish occupation time line (consider mission and its relation to scheme of maneuver and supported unit time line). _____
- Fill gaps in the position with individual fighting positions. _____

POSITION OCCUPATION CHECKLIST (CONTINUED)

- Ensure each fire unit coordinates with the unit to the left and right. _____
- Ensure each position has a range card. _____
- Ensure LPs and OPs (if applicable) have the following: _____
 - 1. Cover and concealment. _____
 - 2. Communications. _____
 - 3. Range card (Stinger/M3P). _____
 - 4. Sufficient distance from position to provide early warning. _____
- Camouflage positions and vehicles. _____
- Plan and conduct the following: _____
 - 1. Ammunition resupply. _____
 - 2. POL resupply. _____
 - 3. Water resupply. _____
 - 4. Ration resupply and feeding. _____
 - 5. Maintenance support. _____
 - 6. Evacuation plan. _____
- Submit necessary reports. _____
- Enforce noise, light, and litter discipline. _____
- Brief everyone on— _____
 - 1. Tactical situation. _____
 - 2. Mission. _____
 - 3. Challenge and password. _____

PLATOON COORDINATION CHECKLIST

Note: This checklist is for platoon leaders for coordination at TF and brigade TOC.

- Visit all staff sections and exchange information. Pay particular attention to the staff planning and orders process. Pass the information gathered to ADA head-quarter (HQ).
- 1. S3. _____
 - a. Commander's intent. _____
 - b. Frontline trace (operations overlay). _____
 - c. Friendly air or ground situation. _____
 - d. Mission. _____
 - e. Supported force rehearsal location and time. _____
 - 2. S2. _____
 - a. Current enemy situation. _____
 - b. IPB (air and ground) requirements. _____
 - 3. Administrative and logistics operations (ADMIN/LOG) (S1/S4). _____

PLATOON COORDINATION CHECKLIST (CONTINUED)

- a. Personnel reporting and replacement procedures. _____
- b. Maintenance and vehicle recovery. _____
- c. Rations and water resupply. _____
- d. Casualty evacuation. _____
- e. Ammunition resupply. _____
- f. POL resupply. _____
- 4. NBC officer. _____
 - a. NBC situation. _____
 - b. Location of decontamination points. _____
- 5. Communications and electronics officer. _____
 - a. Current SOI requirements and changes. _____
 - b. Radio replacement procedure. _____
 - c. Current COMSEC requirements and changes. _____
- Attend all briefings. _____
- Keep supported force informed on all AD engagements and section dispositions. _____
- Keep supported force informed of AD warnings, hostile criteria, and WCS. _____
- Coordinate for Avenger FUs' security. _____

PLATOON COMMAND POST CHECKLIST

- Ensure good communications with-
 - 1. Battery. _____
 - 2. Sections. _____
 - 3. Sensors. _____
 - 4. Supported unit. _____
- Observe COMSEC/ECCM procedures:
 - 1. Enter net according to unit SOI procedures. _____
 - 2. Establish platoon net. _____
 - 3. Enforce net discipline. _____
- Ensure all required reports are identified and submitted in a timely manner. _____
- Establish maintenance recovery procedures for platoon. _____
- Ensure AD information is disseminated during OPORD briefs. _____
- Ensure logistical resupply of the platoon occurs. _____
- Ensure all TOC supplies are on-hand. _____
- Know current SOI and authentication passwords. _____
- Know and display on map the current locations of all sections. _____
- Ensure second in command is briefed on plans and operations so he can take over in your absence. At a minimum, _____

PLATOON COMMAND POST CHECKLIST (CONTINUED)

- but not limited to-
- 1. Mission. _____
- 2. Platoon combat power. _____
- 3. Frontline trace. _____
- 4. Friendly air and ground situation. _____
- 5. Enemy air, ground, NBC, and EW situation. _____
- 6. Location of decontamination points and clean and dirty routes. _____
- 7. SOI requirements and changes. _____
- 8. Bridging, route, and obstacle information. _____
- Take corrective action on down equipment. _____
- Make coordination with adjacent units. _____
- Ensure sections with nonoperational equipment still observe cover and concealment. Camouflage disabled vehicles. _____
- Ensure sections with problems continue to provide AD coverage to the greatest extent possible. A disabled fire unit may still be able to shoot. _____
- Ensure platoon performs before-, during-, and after-operation maintenance on all equipment. _____
- Ensure adequate security measures are taken for classified documents and other sensitive items. _____
- Ensure platoon members are clean shaven and perform personal hygiene daily. _____

PLATOON OPERATION CHECKLIST

- Planning phase.
- 1. 1/3-2/3 rule. _____
- 2. Perform backward planning. _____
- 3. Properly consider factors of METT-T in planning. _____
- 4. Present recommendations to commander or S3 regarding allocation of assets. _____
- 5. Actively participate with supported unit staff during planning process. _____
- 6. Plan platoon rehearsal (location, time, and duration). _____
- 7. Ensure supported force AD plan is doctrinally sound. _____
- 8. Template planned weapons coverage. _____
- 9. Properly analyze enemy air avenues of approach. _____
- 10. Ensure AD plan compensates for system limitations. _____
- 11. Ensure AD plan compensates for maintenance and combat losses. _____
- 12. Ensure AD plan supports commander's scheme of maneuver and intent. _____

PLATOON OPERATION CHECKLIST (CONTINUED)

- 13. Accomplish contingency planning. _____
 - 14. Address AD rearm, refuel, and maintenance. _____
 - 15. Address AD of supported force rearm, refuel, and movement operations. _____
 - 16. Discuss night and limited visibility operation. _____
 - 17. Discuss Avenger ground support role. _____
 - 18. Address AD plan in assembly areas. _____
 - 19. Address receipt and dissemination of WCS end ADW. _____
 - 20. Address early warning and sensor management. _____
 - 21. Address employment of air guards and engaging enemy air with organic weapons. _____
 - 22. Perform adequate reconnaissance to position occupation. _____
 - 23. Provide AD for orders group during planning. _____
 - 24. Plan coverage for choke points and passage points. _____
 - 25. Consider prestock of ammunition. _____
 - 26. Coordinate weapon emplacement positions with local commander who owns the ground. Make provisions for alternate and secondary positions. _____
 - 27. Plan medical evacuation of casualties through supported unit or ADA battery. _____
 - 28. Plan PTLs, sectors of search, and SOFs. _____
- Preparation phase.
- 1. Brief all personnel on the OPORD at once. _____
 - 2. Extractor address pertinent elements of supported unit OPORD in platoon OPORD. _____
 - 3. 1/3 of available time allocated to planning and 2/3 of available time allocated for execution. _____
 - 4. Move personnel into position or perform face-to-face coordination for weapon emplacement with supported force. _____
 - 5. Verify that AD personnel and supported force elements use proper camouflage. _____
 - 6. Verify that AD personnel are prepared to defend at first light. _____
 - 7. Verify that precombat checks and PMCS are accomplished, Avengers are boresighted, and IFFs are programmed. _____
 - 8. Verify that range stakes and range cards are properly prepared. _____
 - 9. Verify that Class III and V uploads are accomplished in a timely manner. _____
 - 10. Check AD coverage of TF and or supported unit road march and preparation. _____
 - 11. Verify complete dissemination and understanding of OPORDs with backbriefs. _____

PLATOON OPERATION CHECKLIST (CONTINUED)

- 12. Verify that initial and ongoing liaison is conducted by AD squads end supported elements. _____
 - 13. Check preparation of primary and alternate and supplementary positions. _____
 - 14. Verify request and receipt of engineer support. _____
 - 15. Template actual weapons coverage. _____
 - 16. Conduct rehearsals et all echelons. _____
 - 17. Conduct backbriefs. _____
 - 18. Verify that Avengers era dug in. _____
 - 19. Verify that prestocked ammunition is dug in. _____
 - 20. Verify that adjacent unit coordination has been accomplished. _____
 - 21. Verify dissemination of engineer obstacle overlay (Are clear lanes and the location of minefields known?) _____
 - 22. Conduct coordination for medical evacuation on the ground with supported unit. _____
- Execution phase.
- 1. Immediately pass any enemy information to the platoon. _____
 - 2. Platoon kept informed on disposition of squads and supported unit. _____
 - 3. Adequate communications maintained to facilitate C². _____
 - 4. Change in WCS/ADW and LADW passed to the platoon and supported unit. _____
 - 5. "Flash" attack warning made to the platoon and to maneuver elements. _____
 - 6. AD engagement reports, situation reports (SITREPs), and spot reports (SPOTREPs) sent in a timely fashion. _____
 - 7. Adjustments made to compensate for maintenance and combat losses. _____
 - 8. Hostile aerial platform properly engaged by AD weapons. _____
 - 9. Hostile aerial platform properly engaged by organic non-ADA weapons. _____
 - 10. Supported unit reacting appropriately to enemy air attack massing small arms fire. _____
 - 11. Platoon reacting properly to artillery. _____
 - 12. Platoon properly responding to NBC conditions. _____
 - 13. Combat reload accomplished. _____
 - 14. Movement techniques consistent with supported movement. _____
 - 15. Choke points properly defended. _____
 - 16. Avenger .50-caliber fires controlled and properly executed. _____
 - 17. Sound target engagement techniques employed. _____
 - 18. Chain of command functioning. _____

PLATOON OPERATION CHECKLIST (CONTINUED)

- 19. Individual squads maximizing use of time. _____
Reorganization.
 - 1. Platoon organization reestablished. _____
 - 2. FRAGO issued for follow-on mission. _____
 - 3. Ammunition status reviewed; cross-leveling
accomplished. _____
 - 4. Class III supplies obtained. _____
 - 5. Casualties treated and evacuated. _____
 - 6. Search and scan position improvement continued
during reorganization. _____
 - 7. Parent battery notified to provide maintenance support
or to pass engagement reports. _____
 - 8. Battery or supported unit updated on personnel status;
Class I, III, IV, and V supplies; and combat capability. _____
 - 9. Crews performing PMCS. _____
 - Consolidation.
 - 1. Platoon reestablishes local security. _____
 - 2. Platoon reestablishes AD sector of fire. _____
 - 3. If necessary, the platoon repositions to overwatch the
designated objective. _____
 - 4. Platoon leader prepares and issues FRAGO for
specific tasks or to continue the mission. _____
-

APPENDIX E

EARLY WARNING

Early warning (EW) provides reliable alerting and cueing information to ADA FUs and also provides alerting to other combat, combat support, and combat service support units. Alerting allows them time to apply active and passive air defense measures. Disseminating this information accurately and timely enhances the effectiveness of air defense weapon systems and the accomplishment of the air defense mission. Alerting information tells the FU an aerial platform is approaching. Cueing information tells the FU from which direction the aerial platform will be coming, its location, and its tentative identification. This enables the FU to focus in that direction to detect it at a greater range.

DIGITAL EARLY WARNING

Digital EW track data will be the primary means of early warning communications to the Avenger platoon. Voice EW will be the alternate method. The air battle management operations center (ABMOC) and A²C² element receive track data

simultaneously from the Airborne Warning and Control System (AWACS). The JTIDS track data, along with WCS and ADWs, are transmitted using the EPLRS or SINCGARS to the tactically employed sensor and C² nodes. The

CONTENTS

	Page
Digital Early Warning	E-1
Voice Early Warning	E-3
Directed Early Warning	E-4
Local Air Defense Warning	E-5
Ground-Based Sensor	E-5
Lightweight and Special Divisions Interim Sensor	E-6
Simplified Handheld Terminal Unit	E-6

sensor and C² correlate that information with their own local track data (LSDIS negative 20-kilometer detection range and GBS 40-kilometer detection range) and send it to the Avenger platoon. EW dissemination using SINCGARS requires line of sight (LOS) between the sending and

receiving nodes. EW dissemination using EPLRS does not require LOS alignment. EPLRS also provides the capability to net sensors with the ABMOC and A²C² element. This network eases sharing track data and graphics digitally at all echelons. See the illustration below.

AWACS AND LOCAL DATA

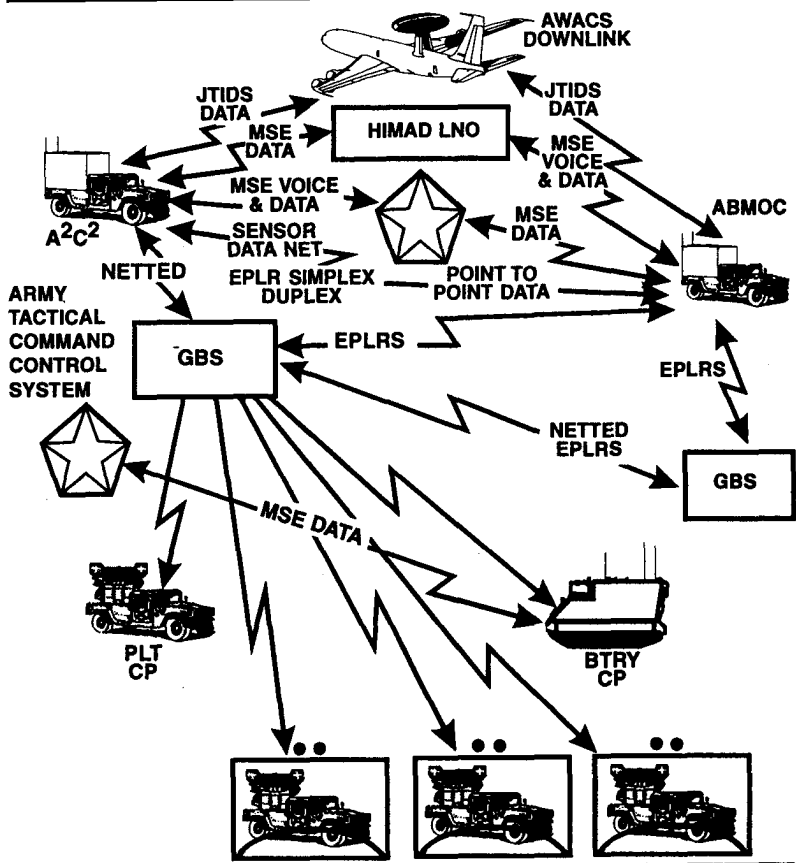

VOICE EARLY WARNING

Voice EW is the method of disseminating directed early warning. It is the alternative to digital early

warning. The illustration below shows a voice early warning network.

VOICE EARLY WARNING NETWORK

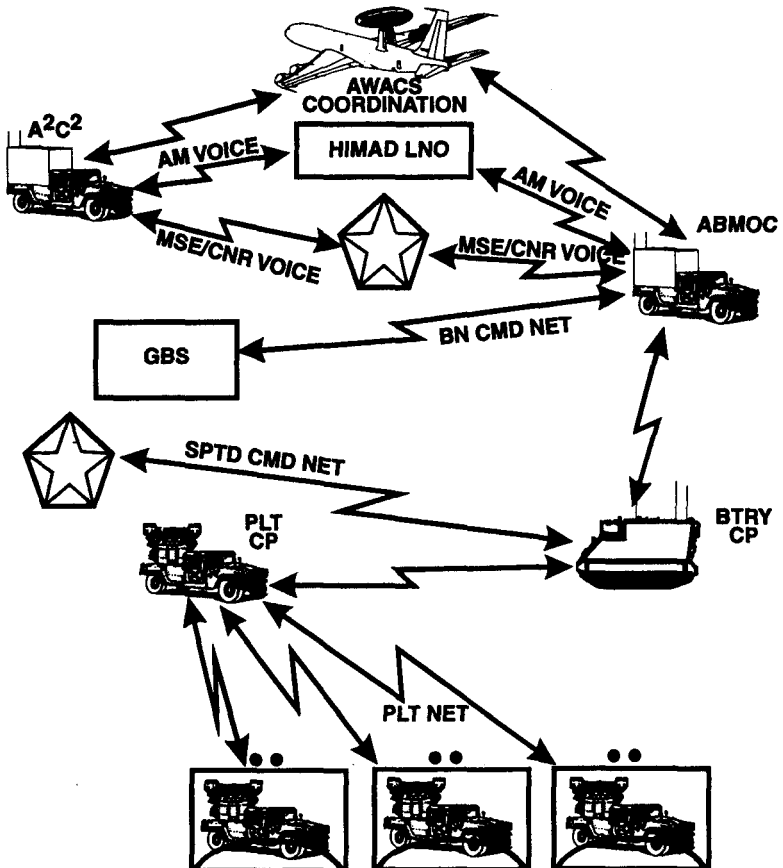

DIRECTED EARLY WARNING

Directed EW must be quick, simple, and redundant in nature. It is imperative that all units, including the supported force, receive EW. It is especially important that units with no air defense assets receive all EW. It states whether the aerial targets are friendly or unknown, provides a cardinal direction, and if known, identifies the most likely affected asset(s) within the supported force. For example, if an EW source reports four enemy Hinds inbound from the east, and the 1st Brigade is attacking along the

eastern axis, the Avenger platoon leader should transmit a LADW message over both the maneuver force command net and the platoon net: "Dynamite! Dynamite! Hinds from the east against Axis Blue!" Dynamite is the LADW that alerts the maneuver force of an attack; the response, per the local SOP, should be immediate. The following diagram indicates how this information will be provided to the Avenger platoon and supported unit. See EW and DEW Distribution for ADA Net illustration.

EW AND DEW DISTRIBUTION FOR ADA NET

In corps Avenger battalions, the ABMOC EW NET may be used in lieu of the DEW.

The ADO must coordinate to ensure the supported unit rebroadcasts EW over command nets at all levels.

* Supported unit monitors DEW or is notified by ADO or TOC air defender.

Squads must be prepared to use the EW scheme in reverse to send spot reports for aerial platforms not previously reported.

To speed EW to FUs consider two techniques:

- All FUs scan the DEW (if SINGARS available).
- Have one or more FUs monitor the DEW for rebroadcast over the platoon and supported nets.

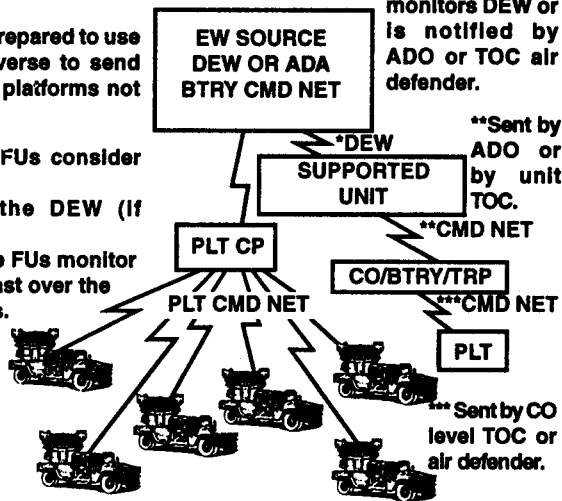

*** Sent by CO level TOC or air defender.

LOCAL AIR DEFENSE WARNING

LADWs are described in Chapter 2. LADWs are designated as Dynamite, Lookout, and Snowman. They parallel air defense warnings (Red, Yellow, and White), but the level of warning is determined by the tactical air defense artillery commander. They are used to alert a unit of an impending air attack.

- Dynamite—airial platform inbound, or attacking locally. Response is immediate.
- Lookout—airial platform in the battle space, but not threatening, or is inbound and there is time to react.
- Snowman—airial platform not in the area of operation, and attack is not probable.

GROUND-BASED SENSOR

GBS with a C³I node is an EW sensor that provides FAAD units with cueing, alerting, and other EW information. Capabilities of the GBS with C³I node are as follows:

- Detects one-square meter targets out to a range of 40 kilometers and from 0 to 4,000 meters above ground level.
 - All weather, 24-hour operations.
 - FAAD C³I and IFF compatible.
 - Acquires high-speed maneuvering FW aircraft up to 40 kilometers out.
 - Can acquire hovering, running, or pop-up helicopter at up to 20 kilometers out.
 - Provides visual display of target location in azimuth and range.
 - Acquires UAVs at a maximum range of 30 kilometers.

- Uses military power sources (10-kilowatt generator) to include organic vehicle power sources.
 - Two-man emplacement or march order for GBS.
 - Two-man emplacement or march order for C³I node.
 - Operable by one soldier.
 - Capable of sharing division picture with other sensors (ABMOC and A²C²) using EPLRS.
 - Provides azimuth and range resolutions of 8 degrees or less and 1,500 meters or less, respectively.

The GBS sensor platoon is made up of three sensor sections. Each sensor section is made up of two sensor teams. Each sensor team is made up of one section chief (SSG), two sensor operators, and two operator/drivers. The other team is made up of one section chief (SGT), two sensor operators, and two operator/drivers.

LIGHTWEIGHT AND SPECIAL DIVISIONS INTERIM SENSOR

LSDIS is the interim FAAD man-portable, rugged, EW sensor that provides FAAD units with alerting and other EW information.

LSDIS capabilities are as follows:

- Detects 2-square meter targets out to a range of 20 kilometers and from 0 to 3,000 meters above ground level.
- Limited weather.
- FAAD C²I and IFF compatible.
- Acquires high-speed maneuvering FW aircraft.
- Acquires hovering and pop-up helicopters up to 8 kilometers.
- Provides azimuth and range resolutions of 8 degrees or less and 1,500 meters or less, respectively.
- Provides visual display of target location in azimuth and range.

- Uses military power sources to include organic vehicle power sources.

- Two-man emplacement or march order.
- Operable by one soldier.
- Airdroppable and transportable by medium helicopters and HMMWVs.

The LSDIS platoon will be assigned to the headquarters and headquarters battery (HHB) of the FAAD battalion and will have six LSDISs for deployment and six sections.

The LSDIS section consists of three crew members: a section chief, a sensor operator, and an operator/driver. The current employment concept requires that the LSDIS be transported by the HMMWV.

SIMPLIFIED HANDHELD TERMINAL UNIT

The SHTU is a state-of-the-art, military lightweight, battery-operated, handheld communications terminal designed for “man on the move” operation and providing digital communications over advanced communications systems. The SHTU has a modular and open architecture allowing for internal and external expansion. Separate numeric keypad and cursor controls provide user friendly operation under

adverse conditions. LCD display provides both bit-mappable graphics and text capability.

Early warning air tracks along with ADW/WCS updates are received on the SHTU. The SHTU requires LOS to the sensor in the light division. This is due to using SINCGARS for EW data and FM voice nets. In the heavy division, this is not a problem due to using the EPLRS for EW data and SINCGARS for FM wire nets.

APPENDIX F

COMBAT OPERATIONS IN VARIED ENVIRONMENTS

This appendix discusses the four environments most commonly encountered in combat operations. They are mountain, jungle, desert, and cold weather environments. Rarely will Avenger platoons operate in jungle and mountainous environments. Generally, MANPADS will provide air defense protection in these rugged environments.

Combat operations cannot be stopped because of rain, snow, ice, extreme heat, lack of water, or rough terrain. These environments present special problems to military operations.

MOUNTAIN OPERATIONS

Mountains of military significance are generally characterized by rugged, compartmented terrain with steep slopes and few natural or man-made lines of communications. The weather is usually seasonal, varying from extreme cold to warm temperatures. Rapid, drastic changes in weather are not unusual in mountainous terrain. The wind can also pose a problem. In cold weather,

the wind chill factor significantly increases the chances of frostbite. Winds are accelerated when forced over ridges and peaks or when converged through passes and canyons.

There are several problems associated with a mountainous environment. Personnel acclimation is required above 2,500 feet. Acclimation is complete only when personnel realize their limitations and

CONTENTS

	Page
Mountain Operations	F-1
Jungle Operations	F-3
Desert Operations	F-4
Cold Weather Operations	F-6

the limitations imposed on their equipment. The effects of high altitude on unacclimated personnel are—

- Increased errors in performing simple mental operations.
- Decreased ability for sustained concentration.
- Deterioration of memory.
- Decreased vigilance.
- Increased irritability and self-evaluation impairment.

There are several health hazards that exist in mountainous climates. These hazards include—

- Snowblindness—more direct sunlight reaches the earth at higher altitudes than at sea level and reflection is increased.
- Frostbite—wind chill factor is increased by strong winds.
- Sunburn—a serious case of sunburn can disable a person for days.
- Dehydration—excessive sweating without replenishing water can happen in mountainous terrain.

Military operations have a unique challenge in mountainous terrain. Some of the physical characteristics of this environment that affect operations are—

- Rugged peaks, steep ridges, deep ravines, and valleys.
- Limited routes of communications.
- Unpredictable weather.
- Availability of natural cover and concealment.

Mountainous terrain offers distinct advantages to attacking enemy

air threats. Air platforms can avoid radar and visual detection by flying low through valleys and mountain passes. They attack or surveil their target with little or no warning. Maneuver forces, combat support, and combat service support units that are road-bound provide lucrative targets. Narrow mountain roads often prevent passing and force one-way traffic. A disabled vehicle may stop a whole column and make it vulnerable to ground fire, indirect fire, or air attacks.

Operations in this terrain favor the use of small, lightly equipped maneuver forces such as—

- Dismounted, accompanying the maneuver forces.
- Pre-positioned, using helicopters for positioning of the teams to provide protection along the maneuver forces' route of march.
- Mixed (dismounted and mounted). Mounted teams trail units by 1,000 meters. (This is especially useful in poor weather when helicopter support is not available.)

Some problems that may be encountered are as follows:

- Reduced early warning because the terrain will cause masking of radars and difficulty in establishing line of sight.
- Reduced ability to visually identify aircraft.
- Degraded distance and quality of FM radio transmission.
- Limitations of dedicated airlift for ammunition and supplies.
- Limitations to the missile system for firing down into valleys.

- Receiving adequate preventive medical care.

- IR increases; however, background clutter noise will also increase.

JUNGLE OPERATIONS

Jungle areas usually are comprised of trees interconnected by a network of thick vines. High temperatures, high humidity, and a heavy annual rainfall create lush vegetation which can seriously impede movement.

There are unique hazards in the jungle. Some of these hazards are as follows:

- Movement by vehicle or foot is difficult.

- Minor terrain features can present major obstacles to movement in combination with the dense vegetation.

- There is great fear of the jungle environment in the minds of personnel.

The health hazards associated with the jungle operations include the following:

- Heat exhaustion and dehydration. High humidity and heat can cause problems without proper water intake.

- Sanitation problems caused by the jungle climate that aids in the flourishing of bacteria.

- Fungus can rapidly cause infections in personnel.

- Jungle diseases are carried by insects.

- Wildlife and poisonous or harmful plants are abundant.

Military operations in the jungle environment have an impact on equipment by requiring an

additional maintenance effort to prevent—

- Rust.

- Corrosion.

- Fungus growth that will cause failure or nonoperation of equipment.

- Problems caused by humidity.

Repair parts, ammunition, and other items should be kept in sealed containers until they are needed to minimize damage from rust and corrosion. Electronic equipment should be kept on so that the heat generated can eliminate moisture which causes corrosion.

Dense jungle offers good concealment for maneuver forces. Defensive action is considerably aided by natural features. Small units are the essential element in all jungle operations. Enemy air attacks will be directed primarily against combat service support units, supply lines, and exposed field artillery units. However, air attack of maneuver forces can be expected when they cross open areas such as rice paddies or rivers.

The ADA unit supporting a maneuver force in a jungle environment will operate by positioning within and moving with the maneuver force. To defend a stationary asset, it will clear trees

and underbrush to have adequate firing positions.

The ADA unit will encounter the following problems in a jungle environment:

- Increased missile problems due to humidity.
- Reduced detection and identification ranges.
- Requirement for teams to be positioned closer together.

- Requirement for more teams to provide balanced fires and mutual support for a particular asset.

- Reduced range of FM radios.
- Extensive use of wire communications or special wavelength antennas.
- Proper individual sanitation to avoid health risks.
- Canopy effect on GBS.

DESERT OPERATIONS

The desert is an arid, barren, and largely treeless environment that can be classified as three different types: mountain, rocky plateau, and sandy or dune desert. The only common denominator is the lack of water. A mountain desert is characterized by high, steep mountains. However, rains in the high areas can cause severe flash floods.

A rocky plateau desert is characterized by relatively slight relief interspersed with large flat areas. Rock is usually at or near the surface, and steeply eroded valleys are common. Flash floods often occur in the valleys.

Sandy or dune deserts are extensive, relatively flat areas covered with sand or gravel. Sand dunes can reach over 1,000 feet high and 15 to 25 kilometers long. Flash floods can occur and cause problems, along with high winds and dust storms.

Acclimation of personnel will be needed to allow for strengthened heat resistance and

physical exertion. While the jungle and desert environments are very different, many of the health hazards are the same. The desert hazards include—

- Dehydration—a resting person may lose as much as a pint of water per hour.
- Heat injuries—sweat evaporates so fast that the cooling of the body is degraded. Personnel should remain fully clothed to retain sweat and aid the cooling process.
- Cold injuries—rapid heat loss from the ground once the sun goes down can cause temperature fluctuations exceeding 70 degrees Fahrenheit.
- Numerous diseases.
- Loss of mental alertness.

Military operations have unique challenges in a desert environment. Some characteristics of a desert operation are as follows:

- Wide dispersion of forces.
- Fast-moving operations and high-speed tactics.

- Navigation problems
- Covered and concealed positions are difficult to find.
- Flash flooding can bog down movement.
- Sand or dust storms will reduce visibility.

Forces will be required to disperse to prevent detection and engagement at long ranges. Vehicle tracks leading into fire positions must be erased or covered to prevent detection from the air.

The ADA unit supporting a maneuver force in a desert environment can expect the following:

- The low, flat terrain aids in detection of enemy air at greater ranges.
- Lack of landmarks causes problems to enemy air in finding and fixing their targets.
- Fire units have a greatly improved chance of destroying the air threat before it attacks the target.
- Fire units have to move rapidly to survive.
- Line of sight can usually be obtained for communications.

While the ADA units will normally be aided in target detection and engagement in the desert, problems will also impact on its operations. Some of these problems are as follows:

- Sand or dust storms may degrade threat detection.
- Dispersion of forces may cause gaps in defenses where

overlapping fires by the fire units are not possible.

- Concealment is difficult, and fire units will need to move often.

- Missile backblast will create a dust or sand cloud revealing the fire unit's position.

- Reduced FM radio range caused by extreme heat and poor grounding of antennas due to lack of moisture in the surface soil.

- Radio dead spaces due to the presence of RF absorbable minerals on or near the surface.

In the desert environment, dust and sand can be as deadly to equipment as enemy fire. Equipment is vulnerable to the extreme heat and cold temperatures of the desert. Problems can occur in the following:

- Vehicle cooling and electrical systems.
- Moving metal parts eroded by sand.
- Rubber parts will dry-rot and crack; tires puncture easily.
- Batteries have a shorter life span.
- Seals break down.
- Deterioration of clothing and equipment.
- Extreme vibrations of equipment on rocky plateaus causes equipment failure and demands preventive maintenance checks and services be performed more often than required by operator maintenance manuals.
- Fuel and air filters require more frequent maintenance.

COLD WEATHER OPERATIONS

The area of cold weather operations is generally defined as the areas lying north and south of the temperate zone. It is characterized by deep snow, permafrost, seasonally frozen ground, frozen lakes and rivers, glaciers, and extreme cold. Vegetation varies from thick evergreen trees to moss and lichens. During summer in permafrost areas, vegetation may mat together over a pool of water that can support soldiers but will not support any type of vehicle. These areas can be extremely dangerous.

There are several problems associated with a cold weather environment. They are—

- Freezing—both wet and dry cold require special clothing.
- Frostbite—skin can become painfully frozen in seconds.
- Hypothermia—the body cannot reheat itself and needs an external heating source to regulate its functions.
- Exhaustion—common in cold climates, especially at high elevations.

- Snowblindness—reflection of sunlight is increased since more direct sunlight reaches the earth.
- Dehydration—heavy clothing will cause increased sweating.

Several factors must be taken into account when planning military operations in a cold weather area. These factors are—

- Mobility—conditions tend to restrict movement on the ground.

- Momentum is difficult to achieve and is easily lost.

- Requirement for heat will place a premium on fuel.

- Camouflage is difficult due to ice fog created by personnel and equipment and tracks left in the snow.

- Navigation is difficult due to lack of aids, blending of features, and blowing snow.

- Night operations are the exception not the rule, because the temperature will drop several degrees during the hours of darkness.

Conditions which tend to restrict movement on the ground have little or no effect on enemy air operations. Roads, hills, and rivers found in all regions provide good navigational aids for enemy aircraft. Road-bound maneuver and support units are easily detected and attacked from the air.

Heavy snow in the winter and poor ground conditions in other seasons may require units to move on foot. The ADA units operating in this environment may encounter the following problems:

- Units will be limited in the amount of ammunition.

- Resupply may have to be made by air.

- Equipment batteries have decreased power levels and drain quickly.

- Special equipment for cold weather is necessary.

- Wearing bulky, heavy clothing and gloves increases the time

necessary to perform the engagement sequence.

- Extreme and prolonged cold weather causes sluggish operations, malfunctions, and broken parts.

To reduce the effects of cold weather, the ADA leader must ensure that proper training in cold environments is conducted and that additional time is provided to perform preventive maintenance.

APPENDIX G

LIMITED VISIBILITY OPERATIONS

This appendix presents the means and methods by which Avenger platoons cope with limited visibility. Platoons that have trained long and hard and have mastered the tactical and technical job skills required will fight effectively even when visibility is limited. Darkness limits visibility on the battlefield, but there are also other conditions that limit visibility.

CONDITIONS

Limited visibility conditions other than darkness are less predictable and more difficult to deal with. Smoke and suppressive fire, which can severely limit local visibility, are used by all armies. Dust and smoke caused by fire and movement of troops in combat often obscure parts of the battlefield. Dust and smoke are especially critical to the effective employment of long-range direct fire weapons. Rain, falling snow, fog, and natural obscurants also hit visibility. Most current night vision

devices and battlefield illumination means have limited effectiveness under these conditions.

The leader's primary task is to coordinate and control the fire and movement of his unit so that he can mass combat power. This is a demanding task when visibility is good, and it becomes even more demanding when visibility is limited. Even in limited visibility, the unit must detect targets, distinguish between friendly and enemy units, effectively engage targets, and navigate.

PLATOON, SECTION, AND SQUAD LIMITED VISIBILITY EQUIPMENT

Modern technology has produced devices that soldiers and

leaders can use to reduce the effects of limited visibility. Several of these

CONTENTS

	Page
Conditions	G-0
Platoon, Section, and Squad Limited Visibility Equipment	G-0
Battlefield Illumination	G-4
Control During Limited Visibility	G-5

devices are organic to the platoon. This section describes the types and number of these devices issued to the platoon and explains how they are employed.

SURVEILLANCE, TARGET ACQUISITION, AND NIGHT OBSERVATION EQUIPMENT

Advanced surveillance, target acquisition, and night observation (STANO) equipment is either active or passive. Active STANO equipment projects some form of energy. This energy, likely radio frequency or infrared, can be detected by the enemy. Passive STANO equipment either detects existing energy emissions or uses available light as a detection means. Use of passive equipment is usually not detectable by the enemy. Active STANO equipment is generally limited to infrared illumination devices. Objects illuminated by these active devices are viewed using passive STANO equipment. There are two categories of passive STANO equipment: image-intensification devices and thermal-imagery devices.

Image-Intensification Devices

Image-intensification devices, or starlight scopes, do not project detectable energy. They amplify the existing or ambient light at night and project an image on a viewing scope. Ambient light may be

moonlight, starlight, or the glow from cities and towns. Light from flares, searchlights, and laser illumination improves the viewing capability but should not be viewed directly with these devices. Image-intensification devices are adversely affected by fog, smoke, heavy rain, and falling snow. Image-intensification devices and binoculars aid where darkness is the only limiting factor.

Thermal-Imagery Devices

Thermal-imagery devices penetrate fog, smoke, camouflage, darkness, rain, falling snow, light vegetation, or a combination of these factors. The principle of this type of device is that all objects radiate energy in the form of heat. This radiated energy travels outward. Because of differences in the amount of heat being radiated, the viewer detects the shape and position of the object being viewed. Thermal-imagery devices can be used in daylight or darkness.

STANO DEVICES

STANO devices greatly improve a unit's ability to carry out its mission under all conditions of visibility. Image-intensification and thermal-imagery devices aid in detecting enemy active STANO devices, such as infrared equipment.

FM 44-44

The platoon may be issued the following STANO equipment: binoculars and AN/PVS-7 night vision goggles.

Binoculars

The platoon headquarters is issued two sets of 7X50-mm binoculars. Each squad is also issued a pair of 7X50-mm binoculars. They are used to acquire long-range targets. At night, binoculars can be used to extend the range of the naked eye by taking advantage of existing light. Binoculars are limited by smoke, dust, heavy rain, falling snow, or fog.

AN/PVS-7 Night Vision Goggles

The AN/PVS-7 night vision goggles (NVG) are a lightweight, battery-powered (3 VDC) device. It is a passive or active night vision device with a 40-degree field of view. The NVG are worn on the head. The battery life is 20 to 75 hours depending on the type of battery used. The NVG weigh 1.5 pounds and have a range of 9.8 inches to infinity in the passive mode. The AN/PVS-7 helps the Avenger commander control the movement of the vehicle as it travels at night on roads or cross-country. The NVG have a built-in active infrared light source which can be used to provide added illumination for close-up viewing within 3 meters. In the active mode, the night vision goggles can be used to read maps,

overlays, or orders. When the active mode is used, the infrared source must be shielded from enemy detection. Inside a building or vehicle, or under a poncho, there is no direct line of sight from the infrared light source to the enemy. The NVG can be used for vehicle maintenance during darkness and can be worn by a ground guide to direct the Avenger. See the Night Vision Goggles illustration.

NIGHT VISION GOGGLES

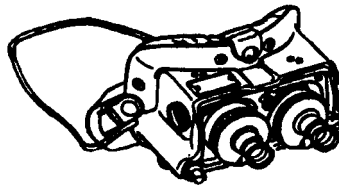

GLOBAL Positioning SYSTEM

The precision lightweight GPS receiver (PLGR) provides highly accurate, continuous, all weather 3-dimensional (3-D) information on position, velocity, and time. It greatly enhances the commander's ability to deploy and fight his FUs based on the ever-changing battlefield.

The NAVSTAR GPS is a space-based navigation and timing system, referred to as AN/PSN-11. It is less than 9.5 inches long, 4.1 inches wide, and 2.6 inches deep. Its weight of 2.75 pounds with

batteries makes the set easy to carry or install in any system. The AN/PSN-11 displays alphanumeric data on a 4-line by 16-character screen; the data is displayed in several formats which depend

on the type of data and operation being performed. See the Precision Lightweight GPS Receiver illustration. For more information pertaining to AN/PSN-11, see TM 9-1425433-10.

PRECISION LIGHTWEIGHT GPS RECEIVER

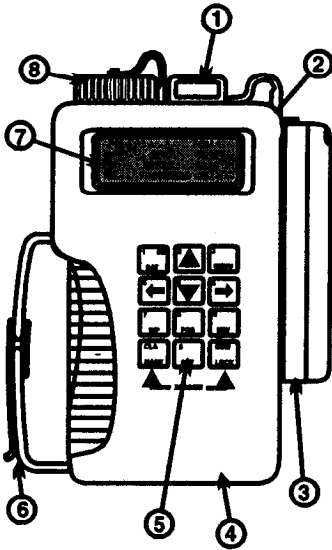

1. KYK-13/KOI-18/SINCGARS CONNECTOR (J1) COVER
Mates with ON199138, pop-off operation, and protects connector.

2. REAR PANEL CONNECTORS (J2, J3, and J4)
Provides access for serial data ports, external antenna, and external power.

3. INTEGRAL ANTENNA
Flip-up swivel compact storage facilitates optimum view angle while receiving satellite signals.

4. MEMORY BATTERY COVER
Screws out for easy replacement of memory battery.

5. KEYPAD
Oversized keys for ease of operation
Dual modes:
Control—for one-handed use
Numeric—for quick two-handed data entry.

6. HANDLE
Easy one-handed operation, facilitates thumb keying, and is adjustable.

7. DISPLAY
4-line x 16-character alphanumeric mode dependent, variable format, and flashing field section.

8. POWER BATTERY COVER
Twists off for easy field replacement of power battery.

BATTLEFIELD ILLUMINATION

Artificial battlefield lighting is an easy way to penetrate darkness. Effective battlefield lighting must illuminate or silhouette the enemy without illuminating friendly forces. There is always a chance that artificial lighting may have an adverse effect on friendly troops. The characteristics of available artificial illumination systems, and how they are influenced by darkness, weather, and terrain, are addressed in this section.

Artificial light is not necessarily visible light. There are two types of artificial light: invisible and visible.

INVISIBLE LIGHT

Invisible light is most often light emitted by an infrared source. It is impossible to see with the unaided eye. It offers greater security than visible light because a night observation device is needed to detect it. But, it is easily detected by active and passive devices.

VISIBLE LIGHT

Visible light is light from flares and searchlights. It requires no special equipment other than the light source itself. It is the simplest type of illumination. Visible light sources are used frequently to continue operations into the night. The disadvantage of using visible light is that it compromises friendly positions and activities.

The platoon uses the following sources of artificial visible light: trip flares, indirect fire illumination, and tank searchlights.

Trip Flares

Trip flares are mainly defensive and are excellent EW devices. They can be set to ignite by rigging them with either a trip wire or a trigger release. Their size and limited burning time make them unsuitable for continuous illumination.

Indirect Fire Illumination

Indirect fire illumination from artillery and mortar fire is the most commonly used form of battlefield illumination. Wind direction must be considered when requesting illumination of this type. Drifting flares may illuminate friendly units. Strong winds may move the burning flare off target. The illumination will not affect the use of the night sight, but if it comes into the night sight's field of view, it will appear as a streak on the screen.

Illumination from artillery or mortar flares is dimmed by fog, dust, smoke, and falling snow. Under these conditions of limited visibility, low-illumination rounds may be used as a navigation aid.

Searchlights

Searchlights are on many types of tanks and in target acquisition batteries of corps artillery. Tank searchlights furnish two types of

illumination: white light and infrared light. Depending on the terrain, enemy situation, and cloud cover, searchlights may provide direct illumination or reflected illumination off low clouds. They can mark targets, objectives, or boundaries. They

can also be used to increase deception by illuminating an area or point outside the intended area of action. The system employing the searchlight is easily detected and extremely vulnerable. It should be used when no other system is available.

CONTROL DURING LIMITED VISIBILITY

Leaders must be ready to use various techniques to control units during limited visibility. These include measures to identify friendly forces, to control movement and fire, and to navigate.

CONTROL

During movement, visual contact can be maintained by reducing the intervals between dismounted soldiers or vehicles. Night vision devices allow units to retain dispersion while maintaining visual contact. When vehicles are moving in any area that has friendly dismounted personnel, such as an assembly area or urban terrain, dismounted guides must be used. Leaders should move forward where they can control the direction and speed of movement.

FIRES

Besides the night sight and other night observation devices, there are several techniques and aids that can be used to control the fires of the Avenger squad. One example would be when in a stationary

position, range cards should be used. Range cards help orient weapons on likely targets and reference points. The platoon should use wire in the defense to establish more reliable and secure communications between the squads, OPs, and section headquarters. Tracers also can be used to denote targets and to direct fire on targets. Pyrotechnic signals, such as hand-fired flares, are other methods that can be used to call for the lifting and shifting of fire.

NAVIGATION

The GPS should be the primary navigational system for the Avenger squad, when available. It provides day and night all weather highly accurate position, velocity, and time, however to aid the navigation process. Whenever possible, guides should be used while moving over unfamiliar terrain. Compasses, visible landmarks, and night vision devices can be used as navigational aids. Artillery spotting rounds may help determine location and direction.

APPENDIX H
**NUCLEAR, BIOLOGICAL, AND
CHEMICAL OPERATIONS**

This appendix addresses nuclear, biological, and chemical defense; mission-oriented protection postures; and decontamination. NBC weapons produce casualties and disrupt operations. Platoons must be prepared to operate in an NBC environment during any operation.

**NUCLEAR, BIOLOGICAL, AND CHEMICAL
DEFENSE FUNDAMENTALS**

To defend against NBC weapons, soldiers must apply the three fundamentals of NBC defense: avoidance, protection, and decontamination. FM 3-100 contains a general discussion of NBC defense measures. FMs 3-3, 3-4, and 3-5 contain detailed information.

**CONTAMINATION
AVOIDANCE**

The first fundamental of defense against NBC weapons is

contamination avoidance. If soldiers can avoid contamination, they decrease the need for protection.

Take Passive Measures

Use concealment, so the enemy cannot find you, or disperse so you make a poor target. You can also harden your position by improving its cover. Other passive measures include operations and communications security.

CONTENTS

	Page
Nuclear, Biological, and Chemical Defense Fundamentals	H-0
Nuclear Defense	H-2
Chemical Defense	H-5
Biological Defense	H-6
Mission-Oriented Protection Posture	H-6
Decontamination.	H-9

Detect and Identify Hazards

Monitor for contamination. Reconnoiter and survey specific areas to determine contamination status. Listen to higher and supported unit nets for reports of contamination or enemy NBC use. Enemy intentions may be discerned by identifying the type of agent. Also, identification gives the platoon an idea of what type of decontamination support is required. If the agent is nonpersistent, weather will reduce it to non-threatening levels in minutes or hours. There is no need to request decontamination units for nonpersistent agents. Decontamination will consist of an operator spraydown using a decontaminating solution applied with an M11 or M13 portable decontamination apparatus. Periodic monitoring with chemical detection paper (M8 and M9) and the M256 chemical detection kit will identify any agent present in threatening concentrations. In a non-persistent agent attack, the unit may only have to remain in MOPP 4 for 30 minutes or less.

Use the NBC Warning and Reporting System

When a hazard is detected, pass the alarm locally. Mark the contaminated area with NATO standard US markers, and report to higher headquarters using standard NBC reports.

Limit Contamination

Cover mission-essential equipment using readily available material. Restrict personnel movement in the contaminated area.

Move From the Contaminated Area

The unit must move if the tactical situation allows. The direction and route of movement can be obtained from higher headquarters. This reduces the overall contamination hazard; however, soldiers must be careful to avoid spreading contamination during movement.

PROTECTION

The second fundamental of defense against NBC weapons is protection. It is required when contamination cannot be avoided. See FM 3-4 for a detailed discussion of personnel and selected equipment protection. Four broad groups of activity can be emphasized as protective measures: hardening positions, using MOPP, reacting to attack, and using collective protection.

DECONTAMINATION

The third fundamental of defense against NBC weapons is decontamination. It reduces the contamination hazard by removing or neutralizing hazardous levels of NBC contamination on personnel and materiel. The extensive time and logistical support needed to perform deliberate decontamination operations mandates avoiding contamination, if possible.

NUCLEAR DEFENSE

Nuclear weapons are tremendously powerful, but defensive measures can be taken to reduce their effectiveness. The more information known about nuclear weapons, the more effective the defense, and the greater the chances of survival.

DEFENSIVE ACTIONS BEFORE A NUCLEAR ATTACK

Cover is the best protection against a nuclear attack. Fighting positions, armored vehicles, heavy structures (concrete, stone, or brick), culverts, and other underground areas provide excellent protection. Light-skinned and wheeled vehicles offer very little protection. Weapons, individual equipment, clothing, supplies, ammunition, explosives, petroleum products, and other flammables should be safeguarded. These items should be secured in one of the protected areas listed above. Nuclear defense levels for possible, likely, and imminent conditions are described in the Nuclear Defense Levels illustration.

NUCLEAR DEFENSE LEVELS

When operating in a radiologically contaminated area, vehicles should be buttoned up, sandbagged, and the cargo covered. If the mission permits, personnel should be closely monitored to ensure

compliance with operational exposure guides. The radiation exposure status should be updated.

DEFENSIVE ACTIONS DURING A NUCLEAR ATTACK

Immediately secure cover while in a prone position and protect exposed skin until blast waves have passed and debris has stopped falling. Stay calm, check for injuries, check weapons and equipment for damage, and prepare to continue the mission.

DEFENSIVE ACTIONS AFTER A NUCLEAR ATTACK

Once the attack has ended, forward an NBC-1 nuclear report, and consolidate and reorganize the AD position. Improve protection against possible fallout by seeking overhead cover for vehicles and begin continuous monitoring. If the radiation dose rate reaches a hazardous level, request permission to move.

NUCLEAR FIRST AID

Various injuries may result from nuclear attack. Soldiers must be prepared to administer first aid as described in the following paragraphs.

Blast Injuries

Damage can range from minor cuts and broken bones to severe lacerations and critical damage to vital organs. First aid treatment will be the same as that used for conventional combat casualties suffering similar injuries.

NUCLEAR DEFENSE LEVELS

NUCLEAR DEFENSE LEVELS	PERSONNEL	RADIOS	EQUIPMENT
A POSSIBLE	OFFENSE Inform personnel and continue mission.	OFFENSE Turn off all non-essential radios. Disconnect antennas and matching unit cables.	OFFENSE Secure all loose equipment. Close and latch all hatches.
	DEFENSE Prepare fighting positions with minimum of 18 inches of overhead cover. Remain in fighting positions or armored vehicles.	DEFENSE Same as offense. Use wire or messenger communications.	DEFENSE Same as offense.
B LIKELY	OFFENSE Inform personnel. Restrict movement away from vehicle or position.	OFFENSE Use one radio per squad. Remove antennas from all unused radios.	OFFENSE Secure all loose equipment. Close and latch all hatches. Turn off all electrical equipment.
	DEFENSE Inform personnel. Prepare fighting positions with minimum of 18 inches of overhead cover. Remain in fighting positions or armored vehicles.	DEFENSE Same as offense. Use one radio per squad.	DEFENSE Same as offense.
C IMMINENT	OFFENSE Inform personnel. Remain in fighting positions or armored vehicles.	OFFENSE Use visual signals to control movement. Use one radio per squad.	OFFENSE Secure all loose equipment. Close and latch all hatches. Turn off all electrical equipment.
	DEFENSE Inform personnel. Remain in fighting positions or vehicles.	DEFENSE Turn off all non-essential radios. Use wire communications.	DEFENSE Same as offense.

Thermal Radiation Injuries

The intense heat generated by a nuclear detonation burns skin, clothes, and equipment. Injuries can be caused by direct exposure, reflected exposures (from clouds and ground), and from secondary sources, such as burning debris. These burns are categorized as first-, second-, and third-degree. First-degree burns should heal without special treatment, and there will be no scar formation. Casualties of a second-degree burn, which resembles a severe sunburn with blistering, are treated as burn casualties to prevent infection. These casualties may require evacuation. In third-degree burns, the full thickness of the

skin is destroyed. The casualty should be treated and evacuated.

Eye Injuries

Thermal radiation's effect on the eyes falls into two categories: temporary blindness (dazzle) and permanent blindness. Individuals temporarily blinded will recover with time, but will require assistance until their sight returns. Individuals suffering permanent damage should be evacuated as soon as possible.

Radiation

Individuals may react differently to radiation exposure, but generally, individuals can be expected to react similarly to certain dose ranges as shown in the Radiation Dose Levels illustration.

RADIATION DOSE LEVELS

DOSE IN CENTIGRAY (cGy)	TIME OF ONSET OF SYMPTOMS AND PERCENT OF PERSONNEL AFFECTED	FATALITIES
0 to 70	Within 24 hours, 5 percent.	None.
150	Within 6 hours, 5 percent.	None.
250	Within 2 hours, 100 percent (latent lethality (LL) dose).	More than half in approximately 15 days.
2,000 to 3,000	Within 5 minutes, 100 percent.	More than half in approximately 7 days.
5,000	Within 5 minutes, 100 percent.	All in 1-2 days.
18,000	Immediately, 100 percent.	All within 24 hours.

Symptoms of radiation exposure include vomiting, diarrhea, dry heavy nausea, depression, and mental disorientation. At lower dose levels, incapacitation and lethargy occur due to a loss of physical mobility or mental disorientation. At higher dose levels, shock and unconsciousness are the early symptoms.

Mechanical injuries such as broken bones, internal injuries, and burns are more serious when the casualty has received minor doses of radiation. Every effort should be made to identify casualties who have been exposed to radiation.

RADIOLOGICAL CONTAMINATION

Platoons exposed to radiation must measure the total dose using the IM93 dosimeter and send dosimetry (exposure) reports to the commander. Commanders must identify units that exceed the operational exposure guidance.

Team members contaminated by radioactive dust or debris perform partial decontamination by brushing, wiping, and shaking debris from their bodies and gear. Contaminated vehicles are partially decontaminated by brushing or washing. This limits the spread of contamination and reduces radiation hazard. Early decontamination is necessary to diminish the cumulative effects of radiation.

CHEMICAL DEFENSE

Chemical agents are used to kill, injure, or incapacitate personnel. The effects produced by these agents are dose-dependent. Through the use of various delivery systems, enemy forces can initiate and sustain large-scale chemical warfare operations.

DEFENSIVE ACTIONS BEFORE A CHEMICAL ATTACK

Make sure all personnel have their protective mask available and that it fits and functions properly. All personnel should be wearing protective clothing

according to the designated MOPP level. The M8 automatic alarm should be put into operation for chemical monitoring and detection.

DEFENSIVE ACTIONS DURING A CHEMICAL ATTACK

Mask and give the alarm. Get into MOPP 4 as soon as possible. Use chemical agent detector paper and M256 chemical detector kits to determine type of agent and forward an NBC-1 report; decontaminate skin and equipment; and continue the mission.

DEFENSIVE ACTIONS AFTER A CHEMICAL ATTACK

Certain defensive actions must be taken following a chemical attack. Perform individual decontamination

as required, treat casualties, and then complete basic individual decontamination.

BIOLOGICAL DEFENSE

Biological agents consist of microorganisms and toxins. Microorganisms are germs that cause diseases. Toxins are poisons produced by plants, animals, or microorganisms. Biological agents, including toxins, can cause death and disease. It is not necessary for biological agents to kill to be effective. Their purpose may only be to reduce the ability of our forces to fight.

DETECTION

Biological attacks are difficult to detect. Sunlight reduces the effects of biological agents. Based on this, the most likely time for a conventional biological attack is in the evening and early morning hours. Some toxins are not sensitive to environmental factors and could be employed in any type of environment.

MISSION-ORIENTED PROTECTION POSTURE

Protective actions against biological and chemical agents depend on the threat, mission, situation, and weather. As with nuclear protective actions, chemical and biological

BIOLOGICAL DEFENSIVE ACTIONS

The best defense is to observe preventive measures such as keeping immunizations up-to-date, maintaining personal hygiene, eating and resting regularly, and providing rodent and insect control. Keep cuts or scratches covered and germ-free by using soap, water, and first aid. Insects carry biological agents. Prevent insect bites by keeping clothes buttoned, covering skin, and using insect repellent.

After an attack, you must assume everything has been contaminated. Only eat rations that have remained sealed. Wash the outside of food and water containers before opening. Use only water from quartermaster water supply points. In emergencies, boil all water for at least 15 minutes or use water purification tablets. Do not use water exposed to toxins or spore-forming microorganisms.

protective actions fall into three categories: action before the attack, during the attack, and after the attack.

MOPP LEVELS

Commanders establish MOPP levels depending on the risk of NBC attack. They use MOPP analysis to determine appropriate MOPP levels based on the tactical situation.

Standardized MOPP levels allow commanders to easily increase or decrease levels of protection. They can raise or lower the amount of protection through five levels of MOPP—MOPP 0 through MOPP4. Commanders may not implement a MOPP level lower than that set by higher headquarter.

The Avenger platoon must understand and apply MOPP levels,

when required, for protection and survival. See the Standardized MOPP Levels illustration. STP 21-1-SMCT has further guidance on wearing MOPP gear.

PROCEDURES BEFORE ATTACK

The Individual and Unit Actions illustration on the next page shows individual and unit actions that must be completed at different MOPP levels prior to an attack. Commanders may modify specific postures to permit mission accomplishment.

STANDARDIZED MOPP LEVELS

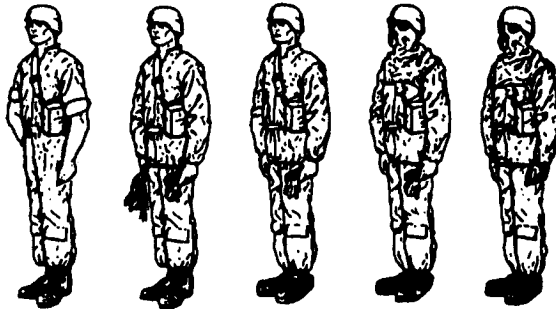

MOPP Level	0	1	2	3	4
Overgarments	readily available	worn*	worn*	worn*	worn
Overboots	readily available	carried	worn	worn	worn
Gloves	readily available	carried	carried	carried	worn
Mask/Hood		carried	carried	worn*	worn
Mask	carried				

*In hot weather, the jacket or hood can be left open for ventilation.

INDIVIDUAL AND UNIT ACTIONS

MOPP LEVEL	INDIVIDUAL	UNIT ACTION (all actions mission permitting)
0	<ul style="list-style-type: none"> • Mask/hood carried. • Overgarments, overboots, and gloves. 	<ul style="list-style-type: none"> • Equipment available.
1	<ul style="list-style-type: none"> • Wear overgarments. • Carry mask/hood, gloves, and overboots. • Place M6 or M8 detector paper on overgarments. • Remain under cover whenever possible. • Sleep or rest only in pup tents, shelters, and vehicles. 	<ul style="list-style-type: none"> • Initiate monitoring with M6 alarms. • Place M8 detector paper on exposed surface of vehicle and equipment. • Cover all grounded equipment, ammunition, and POL products. • Close all hatches, windows, and access plates. • Cover all food and water supplies. • Construct shelter over open hatches when stationary. Construct overhead cover for all individual fighting positions.
2	<ul style="list-style-type: none"> • Wear overgarments and overboots. • Carry mask/hood and gloves. 	<ul style="list-style-type: none"> • Continue actions described under Level 1.
3	<ul style="list-style-type: none"> • Wear overgarments, overboots, and mask/hood. • Carry gloves. 	<ul style="list-style-type: none"> • Continue actions described under Level 1.
4	<ul style="list-style-type: none"> • Wear overgarments, overboots, gloves, and mask/hood. 	<ul style="list-style-type: none"> • Continue actions described under Level 1.

SUPERVISION OF MOPP

Leaders must check their soldiers for proper fit and seal of protective masks and fit of protective clothing. Soldiers must assume stressed positions (bending, twisting, and stretching) to check fit. Compliance with the MOPP level should be checked regularly.

Stress and fatigue can be reduced by rotating heavy work requirements. Allow frequent rest periods, make maximum use of mechanical aids, and provide adequate water supply.

DECONTAMINATION

Decontamination is essential in preventing casualties and combat degradation in a contaminated environment. In the past, when a unit was contaminated, it was withdrawn from battle and went through an 18-hour decontamination to remove all traces of contamination. Tactically and logistically, this approach may not be feasible.

METHODS OF DECONTAMINATION

All personnel need to be familiar with chemical and toxic agents. Being able to distinguish different types of agents will aid in making rapid and educated decisions regarding methods of decontamination.

Immediate Decontamination

The three techniques for immediate decontamination are—

- Skin decontamination.
- Personal wipedown.
- Operator's spray down.

Skin decontamination is a basic soldier survival skill. When chemical and toxic agents get on bare skin, it is an emergency. Some

of these agents can kill if they remain on the skin for longer than a minute. The best technique for removing or neutralizing these agents is to use the M291 or M258A1 skin decontamination kit and continue to monitor the soldier for symptoms after skin decontamination is conducted. The CAM or M8 paper may be used initially to identify nerve of blister type of agents (see TC 3-4-1).

Personal wipedown should begin immediately after skin exposure to liquid contamination or when exposure to liquid contamination is suspected. The wipedown removes or neutralizes contamination on the hood, mask, gloves, and personal weapon. Skin decontamination kits are used for chemical and biological contamination. Soldiers should decontaminate only what is necessary, conserving the CAM and M8/M9 paper and saving time. For radiological contamination, soldiers wipe the contamination off with a cloth or simply brush or shake it away.

Operator's spraydown should begin right after finishing the personal wipedown. The spraydown removes or neutralizes contamination on the

surfaces of the equipment that operators must frequently touch to perform their mission. For chemical and biological contamination, operators use onboard decontamination apparatuses like the M11 or M13. Operating the CAM or using M8/M9 paper will assist in determining what is contaminated. Again, it is important that the soldier conserve time and resources.

For radiological contamination, the soldier should brush or scrape the contamination away with whatever is at hand or flush with water and wipe.

Operational Decontamination

Operational decontamination includes vehicle washdown and MOPP gear exchange. Operational decontamination allows a force to fight longer and sustain its mission while contaminated. It limits the transfer hazard by removing most of the gross contamination on equipment and nearly all of the contamination on soldiers. This speeds the weathering process and allows clean areas, equipment, and people to stay clean. Vehicle washdown can be executed using the concept of supported or unsupported operational decontamination. The contaminated unit (battalion or task force) performs unsupported decontamination using unit decontamination equipment and personnel. This process requires no external support or resources. The unit performs supported washdown with support from a chemical company. The

chemical company mission support priorities will be established by the applicable OPORD available to the platoon through normal procedures.

MOPP gear exchange involves soldiers changing their contaminated gear for clean sets at the operational decontamination site. The squad, section, and platoon are responsible for supervising and conducting their own MOPP gear exchange during hasty decontamination or when the commander authorizes it. Vehicle washdown involves using M12A1 power driven decontamination apparatus (PDDA) or the M17 lightweight decontamination system (LDS). This technique should be completed within one hour.

Thorough Decontamination

Thorough decontamination includes troop decontamination and detailed equipment decontamination. Detailed troop decontamination (DTD) is the process of decontaminating individual fighting equipment to negligible risk levels. Soldiers will remove contaminated MOPP gear to include their protective masks. Protective masks will be decontaminated, and personal equipment will be monitored for decontamination effectiveness. The contaminated unit conducts deliberate troop decontamination with some technical assistance from the chemical unit or unit chemical personnel.

Thorough decontamination operations reduce contamination to

operations reduce contamination to negligible risk levels and restore combat power by removing nearly all contamination from unit and individual equipment so troops can operate equipment safely for extended periods at reduced MOPP levels. A small risk from residual contamination remains, thus periodic contamination checks must be made by leaders. More information

concerning levels of decontamination can be found in FM 3-5.

TECHNIQUES OF DECONTAMINATION

Seven decontamination techniques are used to support the three types of decontamination. The following illustration lists the techniques for each decontamination level.

COMPARISON DATA DECONTAMINATION LEVELS/TECHNIQUES				
LEVEL	TECHNIQUE	BEST START TIME	DONE BY	GAINS
Immediate	Skin decontamination	Before 1 minute	Individual	Stop agent from penetrating.
	Personal wipedown Operator's spraydown	Within 15 minutes	Individual or crew	
Operational	MOPP gear exchange	Within 6 hours	Unit	Possible temporary relief from MOPP 4. Limit liquid agent spread.
	Vehicle washdown		Battalion, crew, or decon platoon(-)	
Thorough	Detailed equipment/ aircraft decon	When mission allows reconstitution	Decon platoon	Probable long-term MOPP reduction with minimum risk.
	Detailed troop decon		Unit	

Notes:

1. The techniques become increasingly less effective the longer they are delayed.
2. Performance degradation and risk assessment need to be considered when exceeding 6 hours. See FM 3-4, BDO risk assessment.
3. Vehicle washdown is most effective if started within 1 hour, but will often have to be delayed for logistical reasons.

APPENDIX I
**AIR IPB IN SUPPORT OF
AVENGER OPERATIONS**

The IPB process allows the commander to visualize the battlefield in terms of predicting where and when the enemy will strike, and what assets he will use. The modern battlefield must be viewed in three dimensions: width, depth, and airspace. Airspace, or aerial dimension, is a constantly changing, fast-paced area of operations. FM 34-130 is the guide that explains the IPB process.

The intelligence staff must consider all the aspects of air operations and must be aware of both enemy and friendly air, airlift, airborne, air assault, air insertion, and air defense capabilities. The task force S2 is the proponent for the development of the IPB. The task force air defense officer must contribute to the IPB development by providing unique insights concerning areas of expertise. Coordination between the air defense officer and S2 about the aerial threat is critical.

Air IPB is conducted from a different perspective than that of ground IPB. The terrain

C O N T E N T S

	Page
Define the Air Battlefield Environment	1-1
Describe the Battlefield Effects (Terrain and Weather Analysis)	1-2
Evaluate the Air Threat	1-3
Determine Air Threat Courses of Action	1-4

and weather have an entirely different effect on air operations. Enemy forces must be evaluated in relation to weather, terrain, and friendly operations. The three threats that must be closely considered when conducting air IPB to protect the maneuver force and its assets are unmanned aerial vehicles (UAVs) and fixed- and rotary-wing aircraft. It is also important to remember that air IPB cannot be treated as a separate entity from ground IPB even though some threat air operations may not be tied directly to their ground operations.

Doctrinally, IPB is divided into four elements as they apply to the air battlefield. They are discussed in the following paragraphs.

DEFINE THE AIR BATTLEFIELD ENVIRONMENT

The air battlefield, like the ground battlefield, includes an area of operations, battle space, and an area of interest.

The air area of operations is the area where the commander is assigned responsibility and authority for military operations. It is usually identical to the ground in width and depth, and extends vertically up to the maximum altitude of air defense sensors and weapon systems.

Battle space is a physical volume that expands or contracts in relation to the ability to acquire and engage the enemy. It includes the width, depth, and height in which the commander positions and moves

assets over time. Battle space is not assigned by a higher commander and can extend beyond the commander's area of operations.

The area of interest is the geographic area from which information and intelligence are required to permit planning or successful conduct of the command's operations. Because the commander and staff need time to process information and to plan and synchronize operations, the command's area of interest is generally larger than the area of operations or battle space. Due to the great distances that aircraft, UAVs, and missiles can rapidly cover, the air area of interest will

extend vertically and horizontally to cover the maximum service ceilings and ranges of threat aircraft,

UAVs, missiles, and delivery systems, plus known or suspected threat airfields and missile sites.

DESCRIBE THE BATTLEFIELD EFFECTS (TERRAIN AND WEATHER ANALYSIS)

The nature of airspace does not eliminate the need for terrain analysis. Air IPB focuses on the impact of geographic factors on the ability of threat air to approach, acquire, and engage a target. The analysis of the terrain for air IPB follows the same principles as analysis of terrain for ground IPB.

OBSERVATION AND FIELD OF FIRE

This relates to the influence of terrain on reconnaissance, target acquisition, intelligence collection, and engagement. In the IPB context, observation relates to optical and electronic line of sight (LOS). Many air and battlefield operating systems require LOS to effectively acquire and engage targets. These systems include radios, radars, jammers, direct-fire weapons, and airborne and ground observers. Field of fire relates to the terrain effects on weapon systems. Analyze battlefield airspace with regard to routes which provide the best protection for aircraft or UAVs entering the target area, and those which provide the best target view once the aircraft or UAV reaches the target area.

COVER AND CONCEALMENT

This applies to the terrain that threat aircraft or UAVs will use to

avoid detection and seek cover from direct fires. Aircraft will use the terrain by loitering on reverse slopes, using pop-up tactics, using masked areas, and by using vegetation as a backdrop to enhance camouflage.

OBSTACLES

For air IPB, obstacles are broken down into three primary types:

- Those which prevent the effective employment of air defense systems.
- Those which restrict contour flying (below 22.8 meters).
- Those which force an aircraft or UAV to employ a particular attack profile or route, or to gain excessive altitude.

Of particular interest are obstacles and terrain which restrict lateral movement within an avenue of approach and movement corridor which will canalize movement and restrict evasive action, and those that are above the threat aircraft or UAV's maximum operating ceiling.

KEY TERRAIN

Key terrain is any locality or area in which the seizure, retention, or control of same affords a marked tactical advantage to either combatant. In air IPB, these consist of terrain features which canalize or constrain air or airborne forces, terrain

with an elevation higher than maximum aircraft, or UAV ceilings, airfields, LZ/DZs, and FARPs.

AIR AVENUES OF APPROACH

Air avenues of approach are evaluated using the same criteria as for ground. A good air avenue of approach will permit maneuver while providing terrain masking from surface-to-air weapon systems. A twisted arrow will be used to denote air avenues of approach. Red arrows will represent threat avenues and blue will represent friendly avenues. Ensure that each air avenue of approach is numbered.

Some common air avenues of approach are—

- A road running down a valley.
- A direct line from the enemy operating base.
- A river bed.

WEATHER

Weather analysis for air IPB considers the effect that conditions will have on the air defenders' ability to detect, acquire, identify, and engage threat aerial platforms. These conditions are—

- High winds.
- Precipitation.
- Cloud cover and ceilings.
- Extreme temperatures and humidity.

EVALUATE THE AIR THREAT

Threat evaluation for air IPB consists of a detailed study of enemy air capabilities, organization, tactics, and doctrine to develop an air threat template of how the enemy might fight if there were no weather or terrain restrictions. It is important to remember that this template will change with each different type of threat faced; Soviet models are no longer used for evaluating the threat.

The following two steps should be used when evaluating the threat:

Step 1—Understand threat doctrine, organization, and capabilities. It cannot be overly emphasized that the air defense platoon and section leaders must have a thorough understanding of operations and capabilities, especially

with regard to the threat air systems that will be operating in the forward area of the battlefield; for example, UAVs, helicopters, and a limited number of fixed-wing aircraft. Threat aircraft profiles and system capabilities will vary depending upon the origin of the equipment and the training support packages provided.

Step 2—Conduct target evaluation. Aircraft operating along the forward edge of the battlefield are probably operating against specific targets. Aircraft usually will be attacking, searching for, or collecting information on high-value targets such as troop concentrations, tactical operations centers, or artillery and logistics sites.

DETERMINE AIR THREAT COURSES OF ACTION

Determining air threat courses of action, as with ground IPB, relates the enemy doctrine and capabilities with weather and terrain to determine how the enemy will fight. This is accomplished through the development of the situation, event, and decision support templates.

The situation template integrates aircraft attack profiles with terrain, focusing on specific air avenues of approach and mobility corridors, to determine which avenues are the most capable of supporting specific attack techniques and profiles.

The event template depicts points (named areas of interest) where you expect to see certain activities of tactical significance and is used to confirm or deny an enemy course of-action. During air IPB, these named areas of interest (NAIs) are based on the terrain constraints on aircraft approach routes to potential targets and analysis of the enemy's attack profiles. Examples of NAIs include DZs and

LZs, forward staging areas, and aerial choke points.

The decision support template is based on the event template and should depict—

- Air avenues of approach.
- Ranges of enemy targets and friendly air defense systems.
- Target areas of interest (TAIs) for attack and reconnaissance.

Air TAIs and DPs are determined in the same manner as for ground operations. However, due to the high speeds of aerial platforms, decision points must be placed significantly farther in advance of the TAIs.

Air IPB is a quantified, step-by-step process that integrates enemy air and ground activity with terrain so that the commander and his staff can visualize the battlefield and fully understand the enemy's intentions. Preparation and continuous updates of aerial IPB are fundamental to the execution of the air defense mission on the modern battlefield.

APPENDIX J
MAPS AND CONTROL MEASURES

This appendix presents some military symbols, descriptions, and control measures which are of operational interest to the ADA platoon. For a complete list, see FM 101-5-1.

Avenger platoon personnel must know how to read and use a map. Each section and or squad leader should have a plastic map case and marker to post operational symbols. Because the loss of key personnel may result in the platoon sergeant or section leader assuming control of the platoon, the platoon sergeant and each section leader must know his location at all times, and have the platoon's operational graphics properly on his map.

Performing land navigation while mounted at high speeds is now easier with the global positioning system (GPS) locator. However, all key leaders must still be able to use terrain association. Making a thorough map study and identifying major terrain feature, contour changes, and man-made structures that exist along a route is essential. As the platoon advances, the platoon, section, and squad leaders must observe existing features and elevation change. They use these and structures on the ground to orient or locate themselves and other elements of the platoon.

CONTENTS

	Page
Color Representation	J-2
Control Measures	J-2
Symbols and Graphics	J-7

COLOR REPRESENTATION

Ideally, different colors are used for enemy and friendly symbols. Different colors may not always be available; therefore, other procedures are needed for one-color symbols as well as for multicolor representation.

ONE COLOR REPRESENTATION

Friendly symbols are outlined by a single line, and enemy symbols are outlined by double lines. For enemy equipment, ground environment, and activities symbols, use the abbreviation EN.

MULTICOLOR REPRESENTATION

The colors on a military map indicate varied meanings. These meanings are given as follows:

- Blue or black indicates

friendly units, posts and installations, equipment, activities, and ground environment symbols not covered by other colors.

- Red indicates enemy units, posts and installations, equipment and activities, and friendly fire support ground environment symbols not covered by other colors.

- Yellow indicates friendly and enemy chemical or radiological areas and enemy biological areas.

- Green indicates friendly and enemy man-made obstacles.

- Other colors used must be explained in a legend.

When overlays are transmitted by facsimile, only black on white is possible. To differentiate between enemy and friendly contaminated areas or obstacles, use the abbreviation EN in the line that defines the enemy area.

CONTROL MEASURES

Most of the control measures commonly used by the battery or supported commander are also used

at the platoon level. See the Control Measures Graphics illustration.

CONTROL MEASURES GRAPHICS

SYMBOL

DESCRIPTION



ASSAULT OBJECTIVE

General assault objective symbol.

Objectives and Intermediate objectives are enclosed and contain the abbreviation OBJ, with a letter, number, code name, or unit designation.

CONTROL MEASURES GRAPHICS (CONTINUED)

DESCRIPTION	SYMBOL
-------------	--------

ASSAULT POSITION

A position between the line of departure and the objective in an attack. It is usually the last covered and concealed position from which the assault force will launch its attack against the objective. It is identified by a name, number, or code.



ASSEMBLY AREA

An area in which a force prepares or re-groups for further action.

(May be designated by numbers, letters, code names, or unit designations.)

Occupied assembly area.

Planned assembly area for a battalion.

Unit symbols displaced to indicate an assembly area for a group of units.

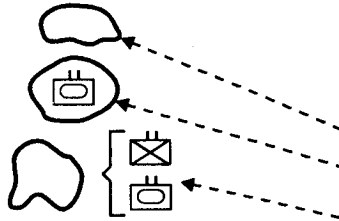

ATTACK POSITION

(May be designated with a number, letter, code name, or unit designation.)

Actual attack position, A Co, 2d Bn, 17th Inf.

Proposed attack position.

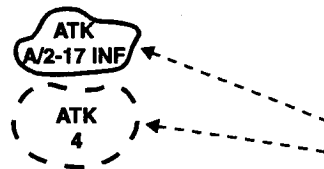

AXIS OF ADVANCE

Actual.

Proposed with date and time effective.

Axis of advance for unit designated to conduct main attack.

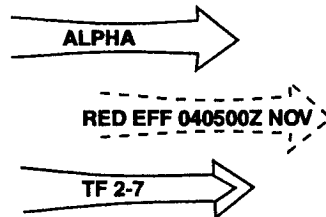

CONTROL MEASURES GRAPHICS (CONTINUED)

SYMBOL

DESCRIPTION

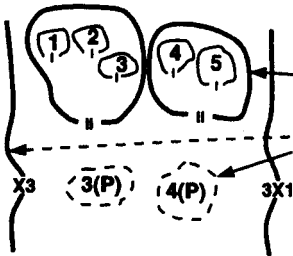

BATTLE POSITION

Occupied battery BP identified at battalion level BP 5. At brigade level, this BP is referred to in conjunction with the battalion BP as BP 2-5. (P) following a position number indicates a prepared position.

Prepared battalion BP for future occupation. Within the 3d Brigade, it would be identified as BP 4.

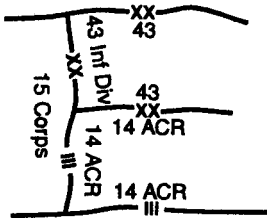
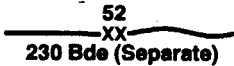
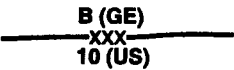
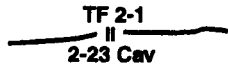
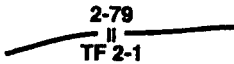

BOUNDARY

Lateral boundaries.

Lateral boundaries are lines with a symbol placed on the boundary to show size and designation of the highest echelons that have the boundary in common. If the units are of unequal size, the symbols of the highest echelon are shown and the designation of the lowest units are given completely.

REAR BOUNDARIES

When used, a rear boundary shows the size symbol for the smaller or subordinate unit rather than that of the target unit of which it is a part.

CHECKPOINT

A predetermined point on the ground used as a means of coordinating friendly movement.



CONTROL MEASURES GRAPHICS (CONTINUED)

DESCRIPTION	SYMBOL
-------------	--------

CONTACT POINT

A designated easily identifiable point on the terrain where two or more units are required to physically meet.



COORDINATION POINT

A specific point where fires and maneuvers between adjacent units are coordinated. It is usually found where a phase line crosses a unit boundary or where the boundary lines extend beyond the FEBA.



DIRECTION OF ATTACK

Direction of attack is shown graphically as an arrow extending from the line of departure. The arrow is not normally labeled.

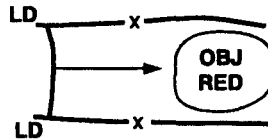

ENGAGEMENT AREA

An area in which the commander intends to trap and destroy the enemy with massed fires. It is routinely identified by a target reference point in the center of the trap area.



LIMIT OF ADVANCE

General LOA symbol.

The symbol is depicted by drawing a line along an easily identifiable terrain feature.

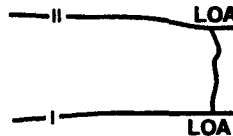

LINE OF CONTACT

General LC symbol.

Enemy symbols depicted with double lines when not portrayed in color.

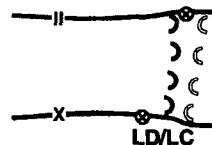

CONTROL MEASURES GRAPHICS (CONTINUED)

SYMBOL	DESCRIPTION
--------	-------------

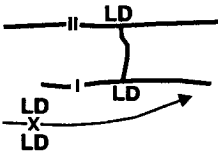

LINE OF DEPARTURE

General LD symbol.

The symbol is a solid line, generally perpendicular to the direction of attack with the letters LD at either end.



PASSAGE POINT

A place where units will pass through one another in an advance or withdrawal.

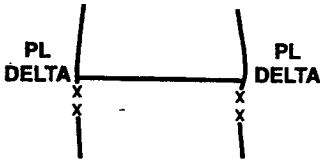

PHASE LINE

Phase lines are labeled PL and are assigned letters, numbers, or code name designations.

PLs are drawn across a unit's sector from boundary to boundary.



POINT OF DEPARTURE



In night attacks, the PD is a specific point on the LD where a unit will cross.



RELEASE POINT

A clearly defined control point on a route at which specific elements of a column revert to the control of their respective commanders. (See also start point.)













CONTROL MEASURES GRAPHICS (CONTINUED)

SYMBOL	DESCRIPTION
	<p>START POINT</p> <p>A clearly defined initial control point on a route at which specified elements of a column of ground vehicles come under the control of the commander having responsibility for the movement.</p>
	<p>TARGET</p> <p>A known or suspected enemy position on which artillery fires are planned. A target is identified with an alphanumeric designation.</p>

SYMBOLS AND GRAPHICS

The Avenger mission relies on the platoon being able to recognize different symbols and graphics. The platoon leader must be able to recognize enemy as well as friendly symbols. Symbols and graphics represent units of varying sizes, and

it also may provide information on equipment activities and other items of military interest. See the ADA Symbols and Graphics illustration on the next page. For more information on symbols and graphics, see FM 101-5-1.

ADA SYMBOLS AND GRAPHICS	
SIZE	SYMBOL
FIRE UNITS	Avenger 
	MANPADS 
	BSFV 
Squad/Crew 	
Section or unit larger than a squad but smaller than a platoon 	
Platoon or detachment 	
Battery 	
Battalion 	
Group or regiment 	
Brigade 	
Task Force 	
Company Team 	

APPENDIX K

THE ENGAGEMENT SYSTEMS

This appendix addresses essential elements that optimize the system's capabilities. Avenger platoons must deny enemy aerial platforms the opportunity to observe or penetrate within striking distance of the supported force or its assets. As in all wars, friendly and hostile aerial platforms operate in the same airspace. This constraint adds pressure to all leaders. It is very important for the Avenger platoon to be able to detect, acquire, identify, and rapidly engage threat aerial targets without fratricide. Speed and accuracy of an engagement depend on leadership and training.

AVENGER WEAPON SYSTEMS

The Avenger FU is top heavy and can easily roll over. The squad must be familiar with the capability of the weapon system. This section discusses the Avenger capabilities. For more information on capabilities and operations, see TM 9-1425-433-10.

FIRE ON THE MOVE

The Avenger squad should not attempt to fire a missile while climbing a 31-degree slope or 22-degree

side slope at more than 4 MPH. For more information on engagement while moving, see ARTEP 44-117-21-Drill.

FIRE FROM REMOTE EMPLACEMENT

The missile or gun can be controlled by the gunner and driver from a remote position. Target engagement using the remote control unit (RCU) follows a similar procedure as used inside the turret when

CONTENTS

	Page
Avenger Weapon Systems	K-1
Weapon Selection Criteria	K-2
Engagement Techniques	K-3
Manual Range Estimation	K-6

using automatic slew-to-cue. For system setup, refer to the Avenger operator's manual and ARTEP 44-117-21-Drill.

MANPADS CONVERSION

The Avenger has specific capabilities under degraded operations. These capabilities allow the Avenger squad to continue the mission when system or terrain conditions cause degraded operations such as equipment failure or terrain characteristics which do not support use of the HMMWV. To convert the missile-round to a weapon-round, see ARTEP 44-117-21-Drill.

M3P .50-CALIBER MACHINE GUN

The primary role for the .50-caliber machine gun is for engagement of aerial targets within the missile's

dead zone. The machine gun may be used on ground targets.

Aerial

The Avenger laser range finder provides distance to target range for firing the machine gun. However, manual range estimation will be used when the laser range finder is inoperative. See the Machine Gun Range Estimation Guide illustration on page K-7. Aerial targets should be engaged with the system in the automatic (25-round burst) mode.

Ground

Ground targets are classified as point targets or area targets. Because of the Avenger's limited basic load of .50-caliber ammunition, ground targets should also be engaged with the system in automatic. Area targets should be engaged using a Z pattern.

WEAPON SELECTION CRITERIA

Weapon selection criteria against enemy threat is critical to the Avenger squad. The selection procedures are one of the most important functions the squad will make. These procedures could be the difference between failure and mission accomplished. The gunner must keep in mind that the Stinger is the primary AD weapon and the .50-caliber machine gun is used to complement the Stinger. The Avenger squad must know the system's dead zone and be prepared to engage targets within the dead zone. The engagement steps

are the same, but the firing techniques are different.

ENGAGING HIGH- PERFORMANCE AERIAL PLATFORMS

High-performance aerial platforms should only be engaged if the aircraft is a direct threat to the FU or supported unit (actually making an attack run). A general rule of thumb is to avoid engaging high-performance aerial platforms with the .50-caliber machine gun because of—

- Target speed.

- Avenger's limited ammunition.
- Brief target exposure time.

ENGAGING HELICOPTERS

The rule of thumb for engaging high-performance aircraft also applies to helicopters. However, when helicopters are exposed on the ground, or are slow-moving or hovering, they become targets of opportunity that should be engaged if within effective machine-gun range.

The Avenger squad should use the following techniques when engaging helicopters with the .50-caliber machine gun. If the

helicopter is flying a crossing or overhead profile, the gunner uses a lead of 50 meters or half the length of a football field. If the helicopter is flying directly toward the Avenger, fire should be directed slightly above the nose of the helicopter. If the helicopter is hovering, the gunner aims just above the fuselage and fires an automatic burst of 25 rounds.

ENGAGING UNMANNED AERIAL VEHICLES

When engaging UAVs, the same principles apply that are used for the engagement of other hostile aerial platforms.

ENGAGEMENT TECHNIQUES

The engagement sequence consists of a series of squad-level actions. Every shooter must detect, acquire, identify, and engage the target to destroy it.

DETECT

Discern the presence of an enemy air element which is or may become a threat.

ACQUIRE

Obtain data defining enemy air element's position. The data must be sufficiently accurate to provide targeting information. The FAAD C³I system will cue FUs to targets.

CUE

Provide the specific and timely positioned data with tentative

identification of aerial platforms within a designated FU's range.

There are three acquisition methods:

- Automatic acquisition. This method involves sensors and the FAAD C³I system providing data sufficiently accurate to place a target within the Avenger's narrow field of view. The GBS provides range, azimuth, and elevation of a target. The FAAD C³I system transmits the data digitally to the SHTU. The squad follows slew-to-cue procedures as outlined in ARTEP 44-117-21-Drill. These procedures automatically place the target within the narrow field of view, and the squad then follows their engagement procedures.

- Manual acquisition. This acquisition method also involves the SHTU, but the target data is not

sufficiently accurate to place the target in the field of view. The data may come from a source that cannot provide a cue. The squad must manually acquire the target using the limited data from the SHTU.

- Autonomous acquisition.

This method describes target acquisition for fire units without FAAD C²I, SHTU, or with degraded capability because of mechanical or communications problems. Under these conditions, the squad will use manual search methods (horizontal and vertical scanning) to acquire targets.

In a horizontal scan, the observer searches the horizon to about

20 degrees (356 mils) above the horizon by moving his eyes in short movements across the sky, working his way up and across. He continues the scan pattern to below the horizon to detect aerial platforms flying close to the terrain (see the Horizontal Scanning illustration).

In a vertical scan, the observer searches the sky using the horizon as a starting point of reference. He moves his eyes in short movements up the sky, then back down, continuing this movement across the terrain. He scans in the same pattern below the horizon to detect aerial platforms

HORIZONTAL SCANNING

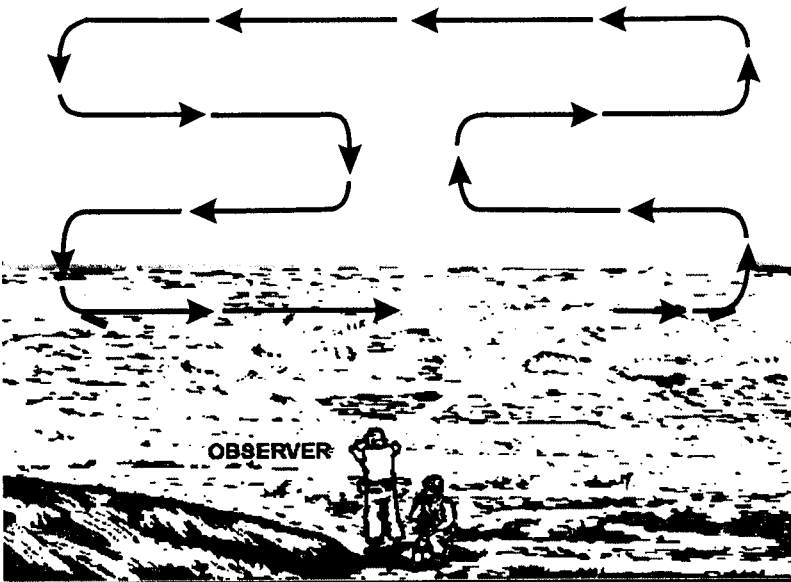

flying close to the terrain (see the Vertical Scanning illustration).

IDENTIFY

Identify is a determination of whether a potential target is friendly or hostile. Identification of fixed- and rotary-wing targets must be visual. Unmanned platforms can be engaged upon recognition under the following conditions:

- Fixed-wing aircraft. Information from the sensor and C² node indicate a FW aircraft which is flying too slow to be a manned fighter and bomber, and visual inspection indicates it is not a helicopter, and

no friendly UAVs are operating in the area.

- Cruise missiles. As soon as it can be determined that the platform is unmanned (3 kilometers maximum range from FU), the target can be engaged. Straight, level flight paths of these platforms will assist in this determination.

ENGAGE

Engage is the decision to fire; this action is conducted upon hostile recognition. The squad leader is the only member of the squad who can make the engagement decision. The gunner has several actions and procedures prior to

VERTICAL SCANNING

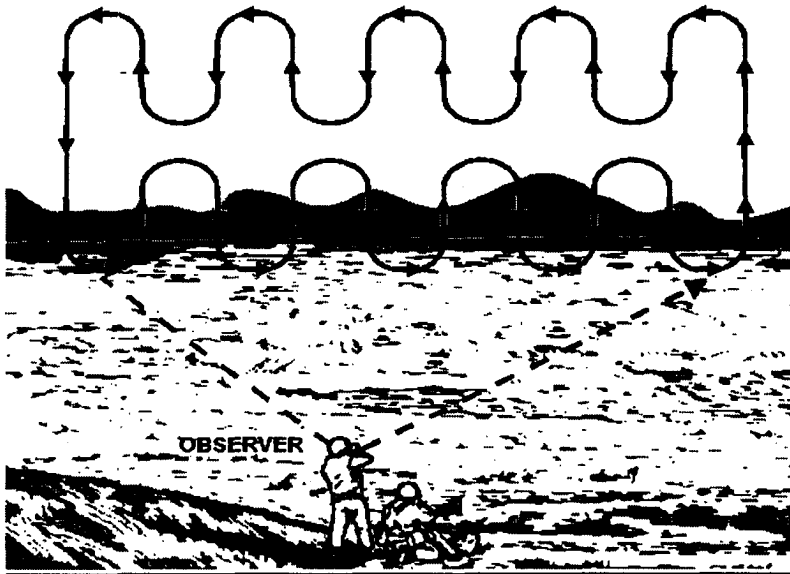

pulling the trigger. For more information pertaining to engagement, see ARTEP 44-117-21 Drill.

DESTROY

Destroy means to kill the target the first time, or prevent it from fulfilling its mission.

MANUAL RANGE ESTIMATION

The Avenger weapon system, like all other modern-day weapon systems, must have a backup system when the main system is nonfunctional. The squad must know how to engage targets using the estimated range techniques, as discussed in the following paragraphs.

the LRF fails or when no fire permit symbol appears during engagement. The Avenger system can fire a missile without the fire permit symbol. Prior to firing, the gunner should apply manual range estimation procedures. See the Missile Range Estimation Guide illustration.

MISSILE MANUAL RANGE ESTIMATION

The Avenger squad must be familiar with manual range estimation techniques. The Avenger gunner applies manual range estimation when

MACHINE GUN MANUAL RANGE ESTIMATION

The Avenger gunner must be familiar with manual range estimation when using the machine gun. To fire the machine gun, the Avenger

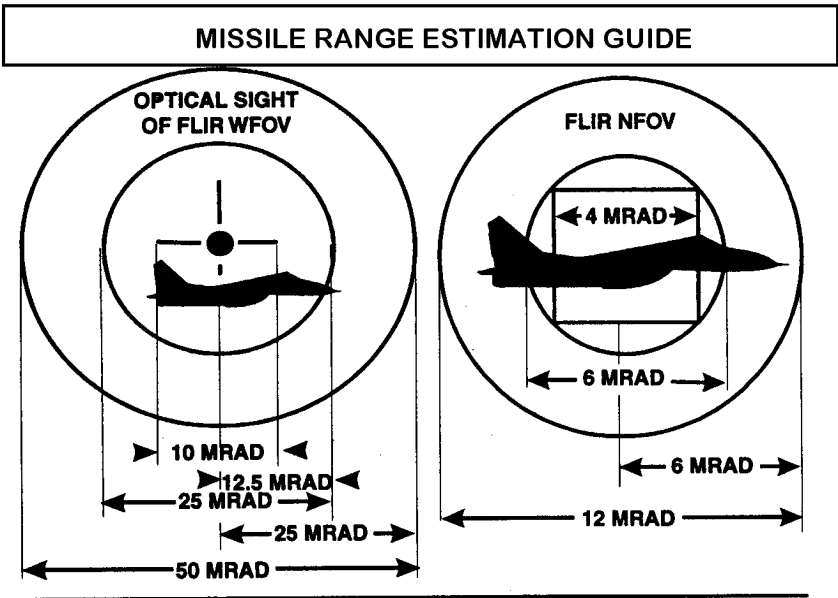

system must have a fire permit symbol. The Avenger fire control computer receives range data from the LRF and computes lead angle and superelevation. The Avenger automatically tracks the target using the proper lead and superelevation. If the LRF fails, the gunner must go to the manual mode. This requires the gunner to manually insert the lead angle and superelevation. Prior to firing the machine gun, the gunner should apply the range estimation procedure. This procedure determines the lead angle and superelevation required to successfully engage the target. Manual range estimation is performed using the steps below:

Step 1. Acquire the aircraft. The gunner acquires the target as described in the Engagement Techniques paragraph of this chapter.

Step 2. Determine the aerial platform characteristics:

- Type aircraft. Is the aerial platform fixed or rotary wing?
- Aircraft flight altitude. Is the aircraft high or low?
- Aircraft flight profile. Is the UAV incoming, outgoing, or crossing?

Step 3. Determine aircraft width. The gunner determines the size of the target in milliradians (MRAD). This is accomplished by using the optical sight or the FLIR. These devices have symbology features that are used to measure the size of the target. The gunner places

the target near the selected symbology and determines the size and range of the aircraft image in MRAD. When using the FLIR for size estimation, the gunner should measure the target based on the FOV selected.

Step 4. Determine if aircraft is in range. Based on the aircraft type, altitude, and image size, the gunner determines if the target is within range of the machine gun. The guidelines in the Machine Gun Range Estimation Guide illustration will assist the gunner in determining range.

MACHINE GUN RANGE ESTIMATION GUIDE

TARGET IN RANGE (MRAD)

AIRCRAFT TYPE	CROSSING	INCOMING	OUTGOING
FW	16.0	6.0	23.5
RW	15.0	1.5	3.5
UAV	TBD	TBD	TBD

Step 5. Determine superelevation and lead angle. Based on the aircraft type, attitude, and range estimate, the gunner determines the superelevation and lead angle. The guidelines in the Turret Adjustment for Lead Angle and Superelevation illustration on the

following page will assist the gunner in determining this information.

Step 6. Check the azimuth and elevation indication on the CDT.

Step 7. Deactivate the FLIR autotrack. Manually track target using the hand controls. Ensure STAB mode is selected. Move the turret in azimuth (ahead of the target) and elevation (above the target). The following illustration shows the turret adjustment procedure.

Step 8. When hostile criteria and WCS are satisfied, fire at the target. Observe the tracer rounds to determine the effect on the target. Use the Hitting the Target illustration on the next page to determine the adjustment needed to hit the target.

Step 9. Make adjustment and continue the engagement.

TURRET ADJUSTMENT

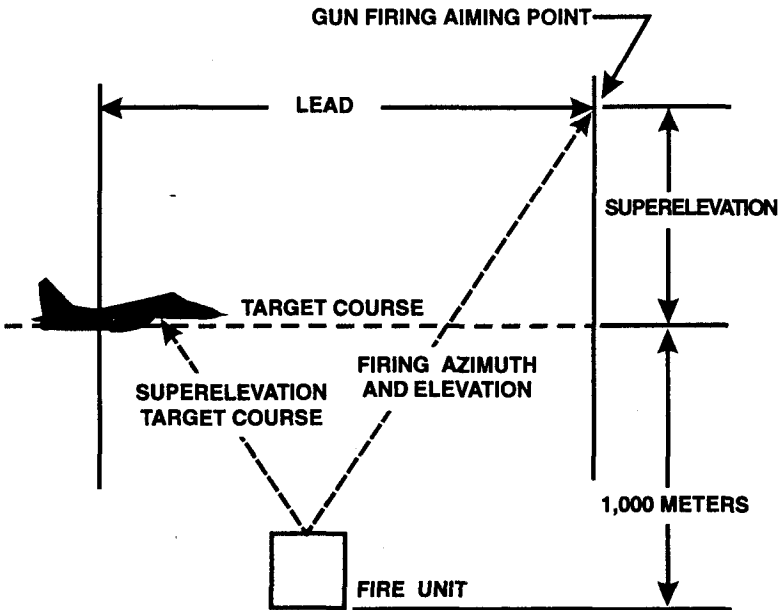

**TURRET ADJUSTMENT
FOR LEAD ANGLE AND SUPERELEVATION**

AIRCRAFT PROFILE	LEAD ANGLE		SUPERELEVATION	
	CROSSING 500 - 1000M	INCOMING 500 - 1000M	INCOMING	OUT-GOING
FIXED WING	30°	1° 1/3°	One Aircraft Length Above Nose	5° Below Nose
ROTARY WING	6°	1° 1/3°	One Aircraft Length Above Nose	2° Below Nose

HITTING THE TARGET

CROSSING AIRCRAFT

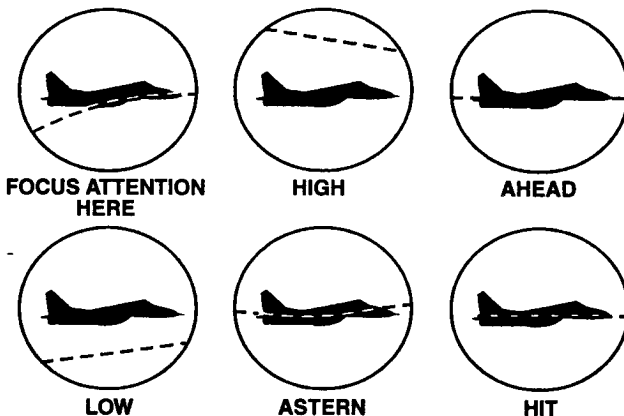

INCOMING AIRCRAFT

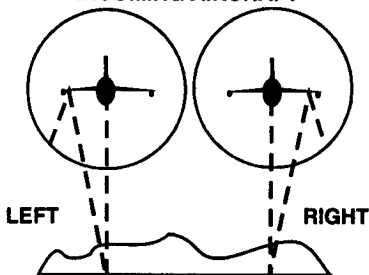

APPENDIX L

SAFETY AND RISK ASSESSMENT

This appendix provides guidelines concerning Avenger safety issues prior to, or during, combat operations. Leaders at all levels must ensure that safety is an ongoing process during war. This includes doing a risk assessment for all operations. Although not all-encompassing, this appendix provides some basic rules of safety. Leaders should add to the subjects in this appendix as they deem necessary. Leaders should add to the subjects in this appendix as they deem necessary.

RISK ASSESSMENT

Tough, realistic training conducted to standard is the cornerstone of Army warfighting skills. An intense training environment stresses both soldiers and equipment, thus creating a high potential for accidents. The potential for accidents increases as training realism increases. Consequently, realistic training poses a risk to personnel and equipment. Commanders must find ways to protect their soldiers and equipment from accidents during realistic training to prepare for

war. An accidental loss in war is no different in its effects than a combat loss; the asset is gone. Commanders must compensate for the advantages of the enemy by protecting their combat resources from accidental loss. How well they do this could be the decisive factor in winning or losing. Commanders and staffs can use the following information as a guide for managing risks as it applies to their organization and mission during peace and war.

CONTENTS

	Page
Risk Assessment	L-0
Avenger Safety Precautions	L-9
Other Hazards	L-9
Vehicle Movements and Convoys	L-11
Safety Briefing Checklist	L-11

CONCEPT

Risk assessment is a tool leaders can use to make smart risk decisions in tactical operations. It allows leaders to execute more realistic training scenarios not otherwise possible because of the high probability of accidents. Risk assessment is a common sense way of training with the least risk possible. It is a method of getting the job done by identifying the areas that present the highest risk and taking action to eliminate, reduce, or control the risk. Risk assessment must be a fully integrated part of mission planning and execution.

RESPONSIBILITIES

Risk assessment is not complex, technical, or difficult. It is a comparatively simple decision-making process to balance mission demands against risks. Once understood, risk assessment is a way to put more realism into training without paying a price in deaths, injuries, damaged equipment, or all three. Risk assessment is not limited to training scenarios. It is performed during actual combat as well as in peacetime. Leaders must learn to assess risks during actual training events and apply the same techniques during combat actions. During combat, risks may be taken, but only after they are evaluated and weighed as they are during training.

Commanders

As in all other areas, commanders are responsible for the effective

management of risk. To meet this responsibility, commanders—

- Seek optimum, not just adequate, performance.
- Select risk reduction options provided by the staff.
- Accept or reject residual risk, based on the benefit to be derived from an informed position knowing what they are accepting or rejecting.
- Train and motivate leaders at all levels to effectively use risk assessment concepts.

Staff

Staff members also have responsibilities in risk assessment. The staff—

- Assists the commander in assessing risks and in developing risk reduction options.
- Integrates risk controls into plans and orders.
- Eliminates unnecessary safety restrictions that diminish training effectiveness.

Troop Leaders

The responsibilities of troop leaders play an important part in how risk assessment is viewed by their subordinates. Their commitment to managing risks will improve the fighting capability of their units. Troop leaders—

- Develop a total commitment to mission accomplishment and the welfare of subordinates.

- Consistently apply effective risk assessment concepts and the methods to operations they lead.
- Report risk issues beyond their control or authority to their superiors for resolution.

PROCESS

The risk assessment process improves the efficiency, effectiveness, and safety in all operations. The payoff of the process is increased readiness as a result of safer, smarter, and more beneficial operations. The process involves four steps.

Identify Risks

Identify major events of the operational sequence and list them chronologically; then, if necessary, display them in a flowchart. This process will aid in the detection of specific risks- associated with all specified and implied tasks. Safety can be built into an operation by first seeing the operation in its entirety. Operations can be broken down into a series of phases, each with special characteristics and considerations. As soon as the commander states the mission and concept, it is usually possible to define the key events. Operations also have a time factor—beginning-to-ending series of events in which the timing of events is often as significant as the events themselves. The operations analysis is a useful tool in quickly defining the flow and time sequencing of events in an operation. The objective is to

reflect the total operation from the preparatory actions until the operation is completed or until the next phase of operation is under way. The operations analysis is a simple but highly effective tool. It ensures that risk is evaluated in every aspect of the operation. Operations safety techniques are effective to a point, but they do not detect risk with the reliability required to achieve the degree of safety needed in today's Army.

Assess Risks

Determine the magnitude of risks by estimating loss probability and cost. Assess each event, determine whether it is routine, and make an initial risk assessment. Ensure that standards for routine events are adequate to provide an acceptable level of risk.

Risk matrix. Consider the value of a risk matrix or decision guide for all or part of the operation. Risk matrices provide a quick and ready method of breaking down an operation into its major operational aspects and eliminating or controlling the risks associated with it. Like other risk assessment tools, risk matrices can be used alone or with other risk analysis techniques to provide a quick overview of the risk situation. Risk matrices are simple enough to be routinely used by tactical leaders in operational planning. These matrices are nearly always more effective than intuitive methods in identifying the extent of risk. The Risk Assessment Work

Sheet and Matrix (Operational) illustration on pages L-7 and L-8 shows a typical matrix that can be used to estimate the level of risk associated with an operation. When using risk matrices, the risk assessor should—

- Review each situation; ensure that all significant areas of concern are evaluated even if they are not included in the matrices.

- Use the matrices to analyze the risk to target areas of concern for risk-reducing action.

- Review the individual areas of concern before recommending an option (If an area of concern is off the scale in a particular situation, a higher decision level may be required than the risk gauge suggests).

- Keep in mind that the risk assessment work sheet arbitrarily weighs factors; modify these factors to fit-particular missions and units.

METT-T. Consider using the mission, enemy, terrain, troops, and time available (METT-T) format as another means to assess risks. Leaders can subjectively determine the likelihood and extent of accidental loss based on this type of analysis. When using the METT-T format, the risk assessor should—

- Determine mission complexity and difficulty.

- Assess the enemy situation and identify specific hazards.

- Consider all aspects of the terrain as well as weather and visibility.

- Determine the supervision required and evaluate the experience, training, morale, and endurance of troops; also, determine the availability of equipment.

Make Risk Decisions

Make risk acceptance decisions by balancing risk benefits against risk assessments. Eliminate unnecessary risks. Reduce the magnitude of mission-essential risks by applying controls. Controls range from hazard awareness to detailed operational procedures. Focus on high-hazard events and events not covered by a good set of standards. Complete a preliminary hazard analysis of these events. The preliminary hazard analysis is the initial examination of the hazards of an operation and their implications. It is normally based on the mission analysis and database review and takes place before the details of an operation have been completely defined. The objectives of the preliminary hazard analysis are to define, at the earliest possible point in the operational life cycle, the hazards that can be expected. Doing this early means that these hazards can be addressed when they are still preliminary; that is, when the operation is still being planned.

Implement controls. Based on the preliminary risk analysis and products of analytical aids, develop a roster of options for command decision. Once risks are identified and measured as accurately as possible, the leader must act to eliminate or

control them. These controls must not unnecessarily interfere with training objectives. The best options often come from reviewing doctrinal publications relevant to the operation to glean information about the proper procedures for hazard control. Merely reviewing the analysis and assessment will often suggest options. Some options will be more effective than others. AR 385-10 provides a convenient list of actions that commanders can use as an aid in ranking options. In order of priority, commanders should—

- Eliminate the hazard totally if possible. Engineer out the hazard or design equipment to eliminate the hazard or incorporate fail-safe devices.

Example: A soldier in SWA was killed when his poncho was caught in a power takeoff shaft on a desalination plant. Why was a metal plate or wooden box not placed over the shaft to prevent this?

- Guard or control the hazard. Use automatic monitoring or alarming devices. Provide containment or barriers.

Example: In the example above, a barrier could have been placed between the soldier and the hazard. In combat operations, control lines that limit subordinate unit operations are an example of controls. At the unit level, limiting vehicle traffic within a perimeter is a control measure that keeps traffic away from sleeping areas.

- Change operational procedures to limit exposure. Modify operational procedures to minimize exposure (numbers and duration) consistent with mission needs.

Example: In Desert Shield and Desert Storm, 5 soldiers were killed and 28 injured because of improper misfire procedures. Having soldiers clear their weapons and remove the magazine when not on guard duty may be an effective reduction measure if the enemy situation allows.

- Train and educate personnel in hazard recognition and avoidance.

- Provide protective clothing or equipment that will minimize injury and damage potential.

- Use color coding and signs to alert personnel to hazards. Motivate personnel to use hazard avoidance actions.

Safety restrictions. Leaders can detect and eliminate unnecessary safety restrictions that impede the realism or effectiveness of training. With proper controls, these restrictions can be eliminated or scaled back. Check for residual effects before implementing risk reduction options. Visualize what will happen once the option has been implemented. Sometimes reducing one risk will only introduce others.

Supervise

Determine the effectiveness of standards in controlling risk. The commander must enforce controls and standards. This is key to loss control. The commander may have approved a number of risk reduction procedures, but approval does not mean that the procedures are carried out. Leaders must monitor the situation to ensure that action is actually taken. The prudent leaders then follow up to see that personnel understand and accept

the guidance. Leaders should also monitor the effect of risk reduction procedures to verify that they really are good ideas. This is especially true for new and untested procedures.

Monitor activities. Leaders must always monitor the operational activities of subordinate elements. Only by seeing the character of operations can leaders fully appreciate risk implications. When monitoring operational activities, leaders should-

- Avoid administrative intrusions and not get in the way.
- Go where the risks are and spend time at the heart of the action.
- Analyze and think through issues, not just watch.
- Work with key personnel to improve operational procedures after the action and not hesitate to address imminent danger issues on the spot.
- Fix systemic problems that are hindering field effectiveness.

Cost of the risk. Leaders must be able to balance the cost of the risk involved with the value of the outcome desired in an operation. They must consider and manage risks in making decisions. Three general rules apply when leaders select a tactical procedure. They are as follows:

- No unnecessary risk should ever be accepted. The leader who has the authority to accept or reject a risk is responsible for protecting his soldiers from unnecessary risks. If a risk can be eliminated or reduced and the mission still be accomplished, the risk is unnecessary and must not be accepted.
- Risk decisions must be made at the appropriate level. The leader who

will answer for an accident is the person who should make the decision to accept or reject the risk. In some cases, this will be a senior officer. In other cases, it will be the first-line leader. Small-unit commanders and first-line leaders will make risk decisions in combat. Therefore, they should learn to make risk decisions in training. Commanders should publish risk criteria information and ensure subordinates understand the parameters within which they may operate.

- The benefits of taking a risk must outweigh the possible cost of the risk. Leaders must understand the risk involved and have a clear picture of the benefits to be gained from taking the calculated risk.

RISK ASSESSMENT TOOLS

Two tools are provided to assist in risk assessment: the risk assessment work sheet and matrix, and the actual risk assessment. These two tools can be modified as desired and placed into safety annexes of SOPs. It then becomes the unit's standard, and modification should not be allowed.

Risk Assessment Work Sheet and Matrix

The risk assessment work sheet is a tool to help in the quantification of the risks. Events can be added and modified based on local unit missions and the commander's intent. See the Risk Assessment Work Sheet and Matrix (Operational) illustration on the two next pages.

**RISK ASSESSMENT WORK SHEET AND MATRIX
(OPERATIONAL)**

Task: _____ **Location:** _____

PLANNING		Preparation		
Guidance	In-Depth	Adequate	Minimal	
Vague	M	H	EH	
Implied	L	M	H	
Specific	L	L	M	

SUPERVISION		Mission		
Command & Control	Nontactical	Day Tactical	Night Tactical	
OPCON	M	H	EH	
Attached	L	M	H	
Organic	L	L	M	

PERSONNEL SELECTION		Experience		
Task	Highly Qualified	MOS Qualified	OJT	
Complex	M	H	EH	
Routine	L	M	H	
Simple	L	L	M	

ENDURANCE		Basic Needs		
Environment	Optimum	Adequate	Minimal	
Tactical	M	H	EH	
Training	L	M	H	
Garrison	L	L	M	

**RISK ASSESSMENT WORK SHEET AND MATRIX
(OPERATIONAL) (CONTINUED)**

WEATHER	Effects on Mission		
	Conditions	Negligible	Moderate
Severe	M	H	EH
Unfavorable	L	M	H
Favorable	L	L	M

TERRAIN	Conditions of the Area of Operations		
	Length of Operation	Improved	Tactical
> 72 Hours	M	H	EH
< 72 But > 24 Hours	L	M	H
< 24 Hours	L	L	M

MISSION-ESSENTIAL EQUIPMENT	Equipment Readiness		
	Availability	Optimum	Adequate
Shortage Critical	M	H	EH
Shortage Noncritical	L	M	H
No Shortage	L	L	M

Legend for Level of Responsibility for Risk Acceptance:

- EH - Extremely High Risk**
- H - High Risk**
- M - Moderate Risk**
- L - Low Risk**

Note: The "elements" listed above are not all-inclusive. Add or eliminate, as needed.

AVENGER SAFETY PRECAUTIONS

Personnel operating and maintaining the Avenger must be constantly aware of the hazards associated with the equipment. All personnel must observe safe practices and procedures.

The Avenger operations manual should be consulted for complete information on equipment hazards. Detailed first aid information and instructions are found in FM 21-11.

The following general safety precautions must be followed to prevent personal injury or equipment damage:

- Never work on electronic equipment unless there is another person nearby who is familiar with the operation and hazards of the equipment and who is competent in administering first aid. A technician, aided by maintenance personnel, must warn all personnel about dangerous areas.

- With power on, personnel must stand clear of the turret during movements.

- Work only in well-ventilated areas when the Avenger is running. Carbon monoxide may be present and is deadly when inhaled.

- Do not walk on tools or components removed from the system. Damage to equipment or injury to personnel can result.

- Do not smoke or have any open flame near or around open containers of fuel or solvents.

- Do not kink, twist, strike, walk on, or otherwise abuse cables and hoses.

- Whenever exposed to smoke or gases, put on the protective mask, close heater ventilator intakes, and wear protective clothing. This will help ensure survivability.

OTHER HAZARDS

The platoon leader must be concerned with all hazards, for the safety of his platoon. Practically all is fair in love and war; therefore, the platoon leader must protect his soldiers from harmful toxins at all times. The following paragraphs will discuss some of those safety measures. For more information, contact the installation safety and health hazards office.

CARBON MONOXIDE POISONING

Carbon monoxide poisoning can kill. Carbon monoxide is a colorless, odorless, deadly poisonous

gas which, when breathed, deprives the body of oxygen and causes suffocation. Exposure to air contaminated with carbon monoxide produces symptoms of headache, dizziness, loss of muscular control, drowsiness, and possible coma. Permanent brain damage or death can result.

Carbon monoxide occurs in exhaust fumes of fuel-burning heaters and internal combustion engines. It becomes dangerously concentrated under conditions of inadequate ventilation. You must follow these safety precautions to ensure safety of personnel whenever the

heater or engine of any vehicle is operated for maintenance or tactical use. The best defense against carbon monoxide poisoning is adequate ventilation.

TOXIC MATERIALS

Toxic materials are located in the vicinity of the missile IR dome. If the dome shatters, mercury thallium liquid may be released. This material is toxic to unprotected skin. Avoid all contact with released material unless protective equipment is being worn (such as a respirator, protective gloves, and chemical goggles).

SOLVENTS

Solvents used in maintenance are volatile and flammable. They produce toxic vapors that are harmful when inhaled. Use only in well-ventilated areas and keep away from flame or sparks. For proper use of lubricants on the Avenger, see the operator's manual.

ACIDS

Electrolyte solution in vehicle and FU batteries contains sulfuric acid. Be extremely careful when handling or working with batteries. Battery acid can cause severe burns and damage to equipment and clothing.

AMMUNITION

Explosives are contained in Avenger machine-gun ammunition. All applicable safety regulations must be strictly enforced. Explosive

components containing electrical wiring must be protected at all times to eliminate stray voltages. Missile-handling operations should not be performed during electrical storms.

MISSILE EXHAUST

Missile exhaust contains amounts of hydrogen chloride gas which may cause eye and throat irritation if inhaled. To prevent any irritation or exposure to potentially harmful concentrations of hydrogen chloride from exhaust plume, the gunner must ensure all hatches are closed and securely latched. For first aid, refer to FM 21-11.

NOISE HAZARD

A dangerous noise level exists in the vicinity of the Avenger system when weapons are fired. Permanent ear damage may result to personnel during weapons firing if they are at close distances. For adequate protection while in the turret, the gunner must wear the communications-type headset provided.

DECONTAMINATION USING DS2

The chemical solution used in the DS2 unit is highly combustible. Severe chemical burns may occur when improperly used. DS2 can severely injure eyes and skin, or may cause illness if inhaled. DS2 can also cause damage to NBC MOPP equipment. For proper use of DS2, see FM 3-5.

VEHICLE MOVEMENTS AND CONVOYS

Proper planning and management of vehicle movements and convoy procedures will affect the number of vehicles on the battlefield, and more importantly, their timeliness in getting there. All leaders should ensure that the following conditions have been met during movement operations:

- Are basic issue items on every vehicle in the convoy?
- Are operators performing before-, during- and after-operation PMCS?
- Are all radio antennas tied down properly to a length of not more than 7 feet?
- Have operators been trained

to drive in adverse weather and difficult terrain?

- Are convoy drivers provided with adequate rest?
- Are ground guides used in the appropriate circumstances such as backing in bivouac areas, and in limited visibility areas?
- Are personnel prohibited from sleeping in vehicles while the engine is running? Are they prohibited from sleeping near or under vehicles?
- Are vehicle dismount points clearly marked and ground guide procedures strictly enforced at all bivouac areas?
- Are fire drills practiced on all vehicles?

SAFETY BRIEFING CHECKLIST

The purpose of a safety briefing checklist is to provide leaders with a ready safety reference that encompasses most tasks common to a unit. The checklist should be used with DA Pamphlet 385-1. Users are encouraged to add additional checklist items that cover their particular mission needs.

When developing a safety briefing checklist, ADA leaders should ensure that the following questions are covered:

- Is the safety annex of the unit SOP current? Does it cover all field training operations?

- Are adequate provisions for safe practices, procedures, and physical standards incorporated into unit predeployment exercises?
- Is there an established procedure for informing the next higher commander of all accidents, injuries, and incidents? Are recommendations for corrective actions made?

The safety briefing checklist on the next page should serve as a guide for ensuring that, as a minimum, these tasks are performed before engaging in training or hostile operations.

SAFETY BRIEFING CHECKLIST GUIDE

- MANPADS safety.** _____
 - Individual weapon safety.** _____
 - Ammunition and or explosive safety.** _____
 - Pyrotechnic safety.** _____
 - Serviceable fire extinguishers.** _____
 - Carbon monoxide poisoning.** _____
 - Vehicle safety (personnel restraints, warning devices, speed, road conditions, road crossings, vehicular river crossings, fuel, spares, and OVM/BI).** _____
 - Convoy procedures (speed, distance, visibility, and routes).** _____
 - Equipment safety.** _____
 - Ground guide safety (dismounted, mounted, and knowledge of equipment).** _____
 - River-crossing safety.** _____
 - Complete first aid kits.** _____
 - Hearing protection.** _____
 - Eye protection (laser, sun, and foreign objects).** _____
 - Head gear and flak vest.** _____
 - Heat and or cold injuries.** _____
 - Environmental safety (pollution control, weather, terrain, poisonous snakes, spiders, and plants).** _____
 - Sleeping safety (In and around vehicles, ventilated areas, and environmental effects).** _____
 - Air assault and airlift safety (In and around aircraft).** _____
 - Tactical antennas.** _____
 - MEDEVAC frequencies.** _____
-

GLOSSARY

A²C² - Army airspace command and control

AA - assembly area

AAA - air avenue of approach

AADC - Army air defense commander

AAM - air-to-air missile

ABMOC - Air Battle Management Operations Center

AC - aircraft

ACA - airlift clearance authority

ACP - air control point

ACR - armored cavalry regiment

active air defense - direct defensive action taken to destroy attacking enemy aircraft or missiles or to nullify or reduce the effectiveness of such attack. It includes such measures as the use of aircraft, interceptor missiles, air defense weapons artillery, non-air defense weapons in an air defense role, and electronic countermeasures and counter-countermeasures (Joint Publication 1-02).

AD - air defense

ADA - air defense artillery

ADADO - assistant division air defense officer

ADCOORD - air defense coordinator

ADCS - air defense coordination section

ADIZ - air defense identification zone

ADLNO - air defense liaison officer

ADMIN/LOG - administrative/logistics

ADO - air defense officer

ADW - air defense warning

air battle management - a fundamental task of air defense command and control and airspace management which encompasses the principles for the control and coordination of both tactical air and ground-based air defense

FM 44-44

resources. Air battle management is exercised through positive and procedural methods.

air corridor – a restricted air route of travel specified for use by friendly aircraft and established for the purpose of preventing friendly aircraft from being fired upon by friendly forces.

air defense (AD) – all measures designed to nullify or reduce the effectiveness of attack by hostile aircraft or guided missiles both before and after they are airborne.

air defense artillery (ADA) – ground-based, surface-to-air weapons, including guns and surface-to-air missiles and support equipment, for engaging air targets.

air strike – an attack on specific objectives by fighter, bomber, or attack aircraft on an offensive mission.

airspace control – a service provided in the combat zone to increase operational effectiveness by promoting the safe, efficient, and flexible use of airspace. Airspace control is provided to permit greater flexibility of operations, while authority to approve, disapprove, or deny combat operations is vested only in the operational commander.

airspace management – the coordination, integration, and regulation of the use of airspace of defined dimensions.

alert – a warning signal of a real or threatened danger, such as an air attack; to forewarn; to prepare for action.

allocation – (1) the translation of the apportionment into total number of sorties by aircraft type available for each operation task and (2) an apportionment of a definite quantity of supplies space services personnel, or productive facility for a specific use.

ALO – air liaison officer

alt – altitude

alternate position – the position given to a weapon, unit, or individual to be occupied when the primary position becomes unsuitable for carrying out its task. The alternate position is located so that the weapon can continue to fulfill its original task.

AM – amplitude modulation

AMC – at my command-a method of control for fire support.

AMO – air movement officer

Glossary-2

ant – antenna

AO – area of operations

AOC – Army Operations Center

APOD – aerial port of debarkation

APP – Allied Publication Procedure

area air defense commander (AADC) – within an overseas unified command, subordinate unified command, or joint task forces, the commander will assign overall responsibility for air defense to a single commander. Normally, this will be the Air Force component commander. Representation from the other service components involved will be provided, as appropriate, to the area air defense commander's headquarters.

ARTEP – Army Training and Evaluation Program

aslt – assault

ASM – air-to-surface missile; aim smart munitions

ASP – ammunition supply point

AT – antitank

ATGM – antitank guided missile

atk – attack

ATP – Allied Tactical Publication; ammunition transfer point

attach – the placement of units or personnel in an organization where such placement is relatively temporary. Subject to limitations imposed by the attachment order, the commander of the formation, unit, or organization receiving the attachment will exercise the same degree of command and control thereover as he does over units and persons organic to his command. However, the responsibility for transfer and promotion of personnel will normally be retained by the parent formation, unit, or organization.

attack – an offensive action characterized by fire and maneuver and culminating in a violent assault or, in an attack by fire, in the delivery of intensive direct fires from an advantageous position. Its purpose is to direct a decisive blow at the enemy to hold him, destroy him in place, or force him to capitulate.

attn – attention

Aug – August

AVT – automatic video tracker

FM 44-44

AWACS – Airborne Warning and Control System

BAI – battlefield air interdiction

basic load (ammunition) – that quantity of nonnuclear ammunition that is authorized and required by each service to be on hand for a unit to meet combat needs until resupply can be accomplished. It is expressed in rounds, units, or units of weight, as appropriate.

battle position – a position on which the main effort of the defense is concentrated. A battle position is made up of a system of defensive sectors that support one another.

battlefield operating system (BOS) – a major function occurring on the battlefield and performed by the force to successfully execute operations. The seven systems are (1) maneuver, (2) fire support, (3) air defense, (4) command and control, (5) intelligence, (6) mobility and survivability, and (7) combat service support. NBC must be integrated throughout each BOS.

BC – battery commander

BCE – battlefield coordinating element

BCS – battery computing system

BCU – battery coolant unit

BDA – battle damage assessment

bde – brigade

BDO – battledress overgarment

BFA – battlefield functional area

BII – basic issue items

BMNT – beginning morning nautical twilight

bn – battalion

BNTOC – battalion tactical operations center

BOS – battlefield operating system

boundary – in land warfare, a line by which areas of responsibility between adjacent units and or formations are defined.

bounding overwatch – a movement technique used when contact with enemy forces is expected. The unit moves by bounds. One element is

always halted in position to overwatch another element while it moves. The overmatching element is positioned to support the moving unit by fire or fire and maneuver.

BP - battle position

BSA - battalion support area

BSFV - Bradley Stinger Fighting Vehicle

btry - battery

c - control

C² - command and control

C³I - command, control, and intelligence

C³ - command, control, and communications

C³I - command, control, communications, and intelligence

CAAD - combined arms air defense

CAM - chemical agent monitor

CAS - close air support

cav - cavalry

cbt - combat

cdr - commander

CDT - control display terminal

CESO - communications-electronics staff officer

cGy - centigray

close air support (CAS) - air action against hostile targets which are in proximity to friendly forces and which require detailed integration of each air mission with the fire and movement of those forces.

CM - cruise missile

cmd - command

CNR - combat net radio

co - company

CO₂ - carbon dioxide

FM 44-44

combat service support (CSS) - the essential logistics functions, activities, and tasks necessary to sustain all elements of an operating force in an area of operations. Combat service support includes, but is not limited to, the assistance provided operating forces primarily in the fields of administrative services, chaplain services, military police, supply, maintenance, transportation, construction, troop construction, acquisition and disposal of real property, facilities engineering, topographic and geodetic engineering functions, food service, graves registration, laundry, dry cleaning, bath, property disposal, and other logistics services.

combat support - fire support and operational assistance provided to combat elements. It includes artillery, air defense artillery, aviation (less air cavalry and attack helicopter), engineer, military police, signal, military intelligence, and chemical.

combat support elements - those elements whose primary missions are to provide combat support to the combat forces and which are a part, or prepared to become a part, of a theater, command, or task force formed for combat operations.

combat trains - the portion of unit trains that provides the combat service support required for immediate response to the needs of forward tactical elements.

COMINT - communications intelligence

command - the authority that a commander in the military service lawfully exercises over subordinates by virtue of rank or assignment. Command includes the authority and responsibility for effectively using available resources and planning the employment of, organizing, directing, coordinating, and controlling military forces for the accomplishment of assigned missions. It also includes responsibility for the health, welfare, morale, and discipline of assigned personnel (Joint Publication 1-02).

command and control (C²) - the exercise of authority and direction by a properly designated commander over assigned forces in the accomplishment of the mission. Command and control functions are performed through an arrangement of personnel, equipment, communications, facilities, and procedures employed by a commander in planning, directing, coordinating, and controlling forces and operations in the accomplishment of the mission (Joint Publication 1-02).

command post (CP) - a unit's or subunit's headquarters where the commander and the staff perform their activities. In combat, a unit's or subunit's headquarters is often divided into echelons; the echelon in which the unit or subunit commander is located or from which he operates is called a command post.

communications security (COMSEC) – the protection resulting from all measures designed to deny unauthorized persons information of value which might be derived from the possession and study of telecommunications, or to mislead unauthorized persons in their interpretation of the results of such possession and study.

COMSEC – communications security

continuity – continuity implies the responsibility of ensuring an operation is not affected by an interruption of support or by unforeseen events.

control – authority that may be less than full command exercised by a commander over part of the activities of subordinate or other organizations.

CONUS – continental United States

COSCOM - corps support command

counterair operations – air operations conducted to attain and maintain a desired degree of air superiority by the destruction or neutralization of enemy territory and are generally conducted at the initiative of friendly forces. The latter are normally conducted near or over friendly forces and are generally reactive to the initiative of the enemy air forces.

CP – command post

CRC – control and reporting center

CRP – control and reporting post

CS – combat support

CSB - corps service battery

CSS – combat service support

cueing – providing specific and timely position data with tentative identification of aircraft within a designated range of a fire unit.

CVC – combat vehicle crewman

DA – Department of the Army

DC – District of Columbia; direct current

decisive engagement - an engagement in which a unit is considered fully committed and cannot maneuver or extricate itself. In the absence of outside assistance, the action must be fought to a conclusion and either won or lost with the forces at hand.

decon – decontamination

FM 44-44

defend – a mission assigned to a unit which requires it to destroy an attacking enemy force or stop it from penetrating the sector or battle position. Subunits of the defending unit may have such missions as defend, delay, or counterattack.

DEW – directed early warning

DISCOM – division support command

div – division

DP – decision point

DS – direct support

DS² – decontaminating solution number 2

DSM – decision support matrix

DST – decision support template

DSU – direct support unit

DTAC – division tactical (operations center)

DTD – detailed troop decontamination

DTG – date-time group

DZ – drop zone

E – east

EA – engagement area

EAC – echelons above corps

early warning (EW) – early notification of the launch or approach of unknown weapons carriers.

ECCM – electronic counter-countermeasures

ECM – electronic countermeasures

ECU – environmental control unit

EENT – end (of) evening nautical twilight

EFF – enemy fighting force

EH – extremely high risk

electronic counter-countermeasures (ECCM) – division of electronic warfare involving actions taken to ensure friendly effective use of the electromagnetic spectrum despite the enemy's use of electronic warfare.

Glossary-8

electronic countermeasures (ECM) – that division of electronic warfare involving actions taken to prevent or reduce an enemy's effective use of the electromagnetic spectrum.

electronic warfare – military action involving the use of electromagnetic energy to determine, exploit, reduce, or prevent hostile use of the electromagnetic spectrum and action which retains friendly use of the electromagnetic spectrum.

ELINT – electronic intelligence

EMCON – emission control

engage – in air defense, a fire control order used to direct or authorize units and or weapon systems to fire on a designated target.

engagement area (killing area or zone) - an area in which a commander plans to force the enemy to concentrate so as to destroy him with conventional weapons.

engr – engineer

EPLRS – enhanced position location reporting system

EPW – enemy prisoner of war

EW – early warning

EWBN – early warning broadcast net

FA – field artillery

FAA – forward alighting area

FAAD – forward area air defense

FAC – forward air controller

FACS – field artillery coordination section

FARP – forward area rearm and refuel point

FASCAM – family of scatterable mines

FAX – facsimile

FDC – fire direction center

FDO – fire direction officer

FEBA – forward edge of the battle area

FEZ – fighter engagement zone

FM 44-44

FFE – fire for effect

field of fire – the area which a weapon or group of weapons may cover effectively with fire from a given position.

field trains – the portion of the unit trains that provides the combat service support not required for immediate response to the needs of tactical elements. They are located rearward to prevent interference independently from the supported tactical unit, and achieve security through passive measures.

fire and maneuver – tactical technique, usually an extension of bounding overwatch, used once contact with the enemy is gained. One element moves while another provides a base of fire.

fire support coordination line (FSCL) - a line established by the appropriate ground commander to ensure coordination of fire not under his control but which may affect current tactical operations. The fire support coordination line is used to coordinate fires of air, ground, or sea weapons systems using any type of ammunition against surface targets. The FSCL should follow well-defined terrain features.

fire support coordinator – the senior field artillery officer at each echelon above maneuver platoon level who serves as the principal advisor to the commander for the planning and coordination of all available fire support.

fire support element (FSE) – a functional portion of a force tactical operations center that provides centralized targeting, coordination, and integration of fires, delivered by fire support means under the control of, or in support of, the force on surface targets.

fire support team (FIST) – in fire support operations, a team comprised of a team chief (FA lieutenant) and the necessary additional personnel and equipment required to request, coordinate, and direct fire support effort for company-size units.

1SG – first sergeant

FIST – fire support team

FLIR – forward looking infrared

FLOT – forward line of own troops

fluid – events easily changed or tending to change.

FM – frequency modulation; field manual

FOB – forward operating base

Glossary-10

forward area rearm and refuel point (FARP) – a temporary facility organized, equipped, and deployed by an aviation unit commander and normally located closer to the area of operation than the aviation unit's combat service area to provide fuel and ammunition necessary for the employment of helicopter units in combat. The FARP permits combat aircraft to rapidly refuel and rearm simultaneously.

forward edge of the battle area (FEBA) – the foremost limit of a series of areas in which ground combat units are deployed, excluding the areas in which the covering or screening forces are operating, designated to coordinate fire support, the positioning of forces, or the maneuver of units.

forward line of own troops (FLOT) – a line which indicates the most forward positions of friendly forces in any kind of military operation at a specific time.

fq – frequency

FRAGO – fragmentary order

fragmentary order (FRAGO) – an abbreviated form of an operation order, usually issued on a day-to-day basis, that eliminates the need for restating information contained in a basic operation order. It may be issued in sections.

FS – fire support

FSB – forward support battalion

FSCL – fire support coordination line

FSE – fire support element

FSO – fire support officer

ft – foot

FU – fire unit

FW – fixed wing

G - group

G2 – Assistant Chief of Staff (Intelligence)

G3 - Assistant Chief of Staff (Operations and Plans)

GBS – ground-based sensor

GPS – Global Positioning System

GS – general support

FM 44-44

GS-R – general support-reinforcing

H - high risk

HHB - headquarters and headquarters battery

HIDACZ – high-density airspace control zone

HIMAD – high-to medium-altitude air defense

HIMEZ – high-altitude missile engagement zone

HMMWV – high-mobility multipurpose wheeled vehicle

HQ – headquarters

hostile criteria – description of conditions under which an aircraft or vehicle may be identified as hostile for engagement purposes.

ICAC² – integrated combat airspace command and control

ID – identification

identification, friend or foe (IFF) – a system using electromagnetic transmissions to which equipment carried by friendly forces automatically responds; for example, by emitting pulses, thereby distinguishing themselves from enemy forces.

IFF – identification, friend or foe

in – inch

indirect fire – fire delivered on a target that is not itself used as a point of aim for the weapon or the director.

insertion – (1) placement of troops and equipment into an operational area in airmobile operations, and (2) the placement of observation posts, patrols, or raiding parties, either by helicopter or parachute.

INT-EXT – internal and external

intel – intelligence

intelligence preparation of the battlefield (IPB) – a continuous, integrated, and comprehensive analysis of the effects of terrain, weather, and enemy capabilities on operations. Using overlays, graphic display, and templating techniques, the IPB process increases the accuracy and timeliness of the intelligence available to the commander. It should start well before combat operations begin.

IP – initial point

Glossary-12

IPB - intelligence preparation of the battlefield

JAAT - joint air attack team

jamming - the deliberate radiation, reradiation, or reflection of electromagnetic energy to prevent or degrade the receipt of information by a receiver. It includes communications jamming and noncommunications jamming.

Jan - January

JEZ - joint engagement zone

JFACC - joint force air component commander

JTIDS - joint tactical information distribution system

km - kilometer

L - low risk

LADW - local air defense warning

LBE - load-bearing equipment

LC - line of contact

LCD - liquid crystal display

LD - line of departure

ldr - leader

LDS - lightweight decontamination system

liaison - that contact or intercommunications maintained between elements of military forces to ensure mutual understanding and unity of purpose and effort.

linkup - a meeting of friendly group forces (such as when an advancing force reaches an objective area previously seized by airborne or air assault forces, when an encircled element breaks out to rejoin friendly forces, or when converging maneuver forces meet).

linkup point - an easily identifiable point on the ground where two forces conducting a linkup meet. When one force is stationary, linkup points normally are established where the moving force's routes of advance intersect the stationary force's security elements. Linkup points for two moving forces are established on boundaries where the two forces are expected to converge.

LL - latent lethality

FM 44-44

LNO – liaison officer

LOA – limit of advance

LOC – line of communications

logistics package (LOGPAC) - a daily resupply of normally Classes I, II, and V, as well as medical and ADA-peculiar items.

LOGPAC – logistics package

LOMEZ – low-altitude missile engagement zone

LOS – line of sight

LP – listening post

LRF – laser range finder

LRP – logistics release point

LSDIS – light and special divisions interim sensor

LZ – landing zone

m – meter

M – moderate risk

main attack – the principal attack or effort into which a commander throws the full-weight of the offensive combat power at his disposal. An attack directed against the chief objective of the campaign or battle.

MANPADS – man-portable air defense system

mask clearance – (1) the absence of any obstruction in the path of a trajectory, and (2) the amount of clearance by which a projectile passes over any object between the weapon and its target.

MEDEVAC – medical evacuation

METT-T - mission, enemy, terrain, troops, and time available

MFCS – manual FAAD control system

MOPP – mission-oriented protection posture

MOS - military occupational specialty

movement technique – manner of traversing terrain (for example, traveling, traveling overwatch, and bounding overmatch). The likelihood of enemy contact determines which technique is used.

Glossary-14

movement to contact – an offensive operation designed to gain initial ground contact with the enemy or to regain lost contacts (in NATO, the term “advance to contact” is used).

MPH – miles per hour

MRAD – milliradians

MRE – meals, ready-to-eat

MRR – minimum risk route

MSE – missile support element

MSR – main supply route

MTC – movement to contact

MTR – missile tracking radar

mutual support – that support which units render each other against an enemy, because of their assigned task, their position relative to each other and to the enemy, and their inherent capabilities.

NAI – named area of interest

NATO – North Atlantic Treaty Organization

NAVSTAR – navigational star

NBC - nuclear, biological, chemical

NBCO – nuclear, biological, and chemical officer

NCS – net control station

NLT – not later than

NMC – non-mission-capable

no – number

Nov – November

NVD – night vision device

NVG – night vision goggles

obj – objective

OCA - operational control authority

obscuration fire – a category of fire using smoke or other obscurants directly on or near the enemy with the primary purpose of suppressing ob-

FM 44-44

servers and minimizing the enemy's vision, both within and beyond their position area.

OCOKA - observation and fields of fire, cover and concealment, obstacles, key terrain, and avenues of approach.

OIC - officer in charge

OJT - on-the-job training

OP - observation post

OPCOM - operational command

OPCON - operational control

operation order (OPORD) - a directive issued by a commander to subordinate commanders for the purpose of effecting the coordinated execution of an operation.

operation overlay - overlay showing the location and strength of friendly forces involved in an operation. It may indicate predicted movements and locations of enemy forces. It is usually substituted for an operation map at the lower echelons as an essential part of an operation order.

operation plan (OPLAN) - a plan for a single or series of connected operations to be carried out simultaneously or in succession. It is usually based upon stated assumptions and is the form of directive employed by higher authority to permit subordinate commanders to prepare supporting plans and orders. The designation "plan" is usually used instead of "order" in preparing for operations well in advance. An operation plan may be put into effect at a prescribed time, or on signal, and then becomes the operation order.

operational command (OPCOM) - the authority granted to a commander to assign missions or tasks to subordinate commanders, to deploy units, to reassign forces, and to retain or delegate operational and or tactical control as may be deemed necessary. It does not of itself include responsibility for administration or logistics. May also be used to denote the forces assigned to a commander.

operational control (OPCON) - transferable command authority which may be exercised by commanders at any echelon at or below the level of unified or specified combatant commands. It normally provides full authority to organize commands and forces and to employ those forces as the commander in operational control considers necessary to accomplish assigned missions. Operational control does not, in and of itself, include authoritative direction for logistics or matters of administration, discipline, internal organization, or unit training.

OPLAN – operation plan

OPORD – operation order

overwatch – (1) a tactical technique in which one element is positioned to support the movement of another element with immediate direct fire, and (2) the tactical role of an element positioned to support the movement of another element with immediate direct fire.

passage point – a point where units will pass through one another either in an advance or withdrawal. It is located where the commander desires subordinate units to physically execute a passage of lines.

passive air defense – all measures, other than active defense, taken to minimize the effects of hostile air action. These measures include the use of cover, concealment, camouflage, deception, dispersion, and the use of protective construction.

PCI – product configuration identification

PD – point of departure

PDDA – power driven decontamination apparatus

PFC – private first class

PL – phase line

PLGR – precision lightweight GPS receiver

plt – platoon

PMCS – preventive maintenance checks and services

POL – petroleum, oils, and lubricants

pop-up point – the location at which aircraft quickly gain altitude for target acquisition and engagement.

positive control – a method of airspace control that relies on positive identification, tracking, and direction of aircraft within an airspace conducted with electronic means by an agency having this authority and responsibility therein.

PP – passage point

primary position – that location which provides the best means to accomplish the assigned mission.

procedural control – a method of airspace control that relies on a combination of previously agreed upon promulgated orders and procedures.

FM 44-44

PSG – platoon sergeant

psn – position

PTL – primary target line

PZ – pickup zone

R – reinforcing

RCS – radar cross section

RCU – remote control unit

remotely piloted vehicle (RPV) – an unmanned vehicle capable of being controlled from a distant location through a communications link. It is normally designed to be recoverable. See **unmanned aerial vehicle**.

RES – reserve

RF – radio frequency

RISTA – reconnaissance, intelligence, surveillance, and target acquisition

ROA – restricted operations area

ROE – rules of engagement

ROZ – restricted operations zone

RP – release point

RPV – remotely piloted vehicle

RSOP – reconnaissance, selection, and occupation of position

rte – route

rules of engagement (ROE) – directives issued by competent military authority which delineate the circumstances and limitations under which forces will initiate and or continue combat engagements with other forces encountered. In air defense, directives that delineate the circumstance under which weapons may fire at an aircraft. The right of self-defense is never denied.

RW – rotary wing

(S) – secret

S2 – intelligence officer

S3 – operations and training officer

S4 – supply officer

SAAFR – standard use Army aircraft flight routes

SBF – support by fire

sct – scout

sec – section

SF – supported force

SGT – sergeant

SHORADEZ – short-range air defense engagement zone

SHTU – simplified handheld terminal unit

SINCGARS – single-channel ground and airborne radio system

SITREP – situation report

SLAR – side-looking airborne radar

SLC – side lobe cancellor

SOI – signal operation instructions

SOJ – standoff jammer

SOP – standing operating procedure

SOR – states of readiness

SOSR – suppress, obscure, secure, and reduce

SP – start point

SPC – specialist

SPOD – seaport of debarkation

SPOTREP – spot report

spt – support

SSG – staff sergeant

stab – stabilized

STANAG – standardization agreement

STANO – surveillance, target acquisition, and night observation

support area - a designated area in which combat service support elements, some staff elements, and other elements locate to support a unit.

FM 44-44

supporting attack – an offensive operation carried out in conjunction with a main attack and designed to achieve one or more of the following: deceive the enemy, destroy or pin down enemy forces which could interfere with the main attack, control ground whose occupation by the enemy will hinder the main attack, or force the enemy to commit reserves prematurely or in an indecisive area.

suppression - temporary or transient degradation of the performance of a weapon system, below the level needed to fulfill its mission objectives, by an opposing force.

surveillance - the systematic observation of aerospace, surface or subsurface areas, places, persons, or things, by visual, natural, electronic, photographic, or other means.

SVML – standard vehicle mounted launcher

SWA – Southwest Asia

TAA – total Army analysis; tactical assembly area

TAC - Tactical Air Command

TACSOP – tactical standing operating procedure

tactical operations center (TOC) – an element within the main command post which consists of those staff activities involved in sustaining current operations and in planning future operations.

TAI – target area of interest

task organization (TASKO) – a temporary grouping of forces designed to accomplish a particular mission. Task organization involves the distribution of available assets to subordinate control headquarters by attachment or by placing assets in direct support or under the operational control of the subordinate.

TASKO - task organization

TASM – tactical air-to-surface missile

TBD – to be determined

TBM – tactical ballistic missile

TBP – to be published

TF – task force

tm - team

TM – technical manual

TMD – theater missile defense

TOC – tactical operations center

TOE – table of organization and equipment

traveling – a movement technique used when speed is necessary and contact with enemy forces is not likely. All elements of the unit move simultaneously with the unit leader located where he can best control.

traveling overwatch – a movement technique used when contact with enemy forces is possible. The lead element and trailing element are separated by a short distance which varies with the terrain. The trailing element moves at variable speeds and may pause for short periods to overwatch the lead element. It keys its movement to terrain and the lead element. It overmatches at a distance such that enemy engagement of the lead element will not prevent the trailing element from firing or moving to support the lead element.

trp – troop

TRP – target reference point

TSOP – tactical standing operating procedure

TTP – tactics, techniques, and procedures

TV – television

TX – Texas

(U) - unclassified

UAV – unmanned aerial vehicle

UMCP – unit maintenance collection point

unmanned aerial vehicle (UAV) – an air vehicle that is remotely or automatically controlled. See **remotely piloted vehicle**.

US – United States

USAADASCH - United States Army Air Defense Artillery School

USAF – United States Air Force

USMC – United States Marine Corps

USN – United States Navy

v – velocity; volts

FM 44-44

VA – vertical angle

VACR – visual aircraft recognition

VDC – video display control

veh – vehicle

vs - versus

vic - vicinity

WARNO – warning order

WCS – weapon control status

weapon control status (WCS) – the degree of fire control imposed upon Army units having an air defense mission in the combat zone. Weapon control status terms normally used are WEAPONS FREE, WEAPONS TIGHT, and WEAPONS HOLD.

weapon engagement zone – in air defense, airspace of defined dimensions within which the responsibility for engagement normally rests with a particular weapon system.

weapons control – the varying degrees of formal control an air defense commander exercises over all air defense weapons in his area of responsibility:

WEAPONS FREE – in air defense, a weapons control order imposing a status whereby weapons systems may be fired at any target not positively recognized as friendly.

WEAPONS HOLD – in air defense, a weapons control order imposing a status whereby weapons systems may be fired in self-defense or in response to a formal order.

WEAPONS TIGHT – in air defense, a weapons control order imposing a status whereby weapons systems may be fired only at targets recognized as hostile.

WEZ – weapons engagement zone

WFZ – weapons free zone

XO – executive officer

REFERENCES

SOURCES USED

- These are the sources quoted or paraphrased in this publication,
- AR 310-25. Dictionary of United States Army Terms. 15 October 1983.
- AR 310-50. Authorized Abbreviations and Brevity Codes. 15 November 1985.
- AR 385-10. Army Safety Program. 23 May 1988.
- ARTEP 44-117-21-Drill. Drills for an Avenger Squad. 15 June 1992.
- ARTEP 44-117-21-MTP. Mission Training Plan for an Avenger Platoon. 18 June 1992.
- ARTEP 44-117-31-MTR. Mission Training Plan for an Avenger Battery. 15 June 1992.
- ARTEP 44-435-MTP. Mission Training Plan for an ADA Avenger Battalion. 29 September 1994.
- DA Form 581. Request for Issue or Turn-In of Ammunition. August 1989.
- DA Form 1155. Witness Statement on Individual. 1 June 1966.
- DA Form 1156. Casualty Feeder Report. 1 June 1966.
- DA Form 2028. Recommended Changes to Publications and Blank Forms. 1 February 1974.
- DA Form 2404. Equipment Inspection and Maintenance Worksheet. January 1964.
- DA Form 5504. Maintenance Request. June 1993.
- DA Pamphlet 310-35. Index of International Standardization Agreements. 15 December 1978.
- DA Pamphlet 385-1. Small Unit Safety Officer/NCO Guide. 22 September 1993.
- DA Pamphlet 738-750. Functional Users Manual for the Army Maintenance Management System (TAMMS). 1 August 1994.
- DD Form 1425. Specifications and Standard Requisition. March 1986.

FM 44-44

- FM 3-3. Chemical and Biological Contamination Avoidance. 16 November 1992 (Change 1, 29 September 1994).
- FM 3-4. NBC Protection. 29 May 1992 (Change 1, 28 October 1992).
- FM 3-4-1 Fixed Site Protection. 16 August 1989.
- FM 3-5. NBC Decontamination. 17 November 1993.
- FM 3-100. NBC Defense, Chemical Warfare, Smoke, and Flame Operations. 23 May 1991.
- FM 6-20. Fire Support in the AirLand Battle. 17 May 1988.
- FM 7-7. The Mechanized Infantry Platoon and Squad (APC). 15 March 1985.
- FM 7-10. The Infantry Rifle Company. 14 December 1990.
- FM 7-20. The Infantry Battalion. 6 April 1992.
- FM 7-30(HTF). Infantry, Airborne, and Air Assault Brigade Operations. 24 April 1981.
- FM 9-6. Munitions Support in Theater of Operations. 1 September 1989.
- FM 9-59. Maintenance Operations for Air Defense and Land Combat Weapons Systems. 8 March 1994.
- FM 11-50. Combat Communications Within the Division (Heavy & Light). 4 April 1991.
- FM 19-30. Physical Security. 1 March 1979.
- FM 20-3. Camouflage. 14 November 1990.
- FM 21-60. Visual Signals. 30 September 1987.
- FM 22-9. Soldier Performance in Continuous Operations. 12 December 1991.
- FM 24-1. Signal Support in the AirLand Battle. 15 October 1990.
- FM 24-18. Tactical Single-Channel Radio Communications Techniques. 30 September 1987.
- FM 24-19. Radio Operator Hand Book. 24 May 1991.
- FM 34-130. Intelligence Preparation of the Battlefield. 8 July 1994.
- (S)FM 44-1A. Air Defense Artillery Operational Planning Data (U). 21 September 1984 (Change 1, 13 May 1986).

References-2

- FM 44-1-2. Air Defense Artillery Reference Handbook. 15 June 1984.
- FM 44-16. Platoon Combat Operations-Chaparral, Vulcan, and Stinger. 29 May 1987.
- FM 44-18. Air Defense Artillery Employment, Stinger. 30 September 1981 (Change 1, 17 May 1985).
- FM 44-18-1. Stinger Team Operations. 31 December 1984.
- FM 44-43. Bradley Stinger Fighting Vehicle Platoon and Squad. 3 October 1995.
- FM 44-64. FAAD Battery and Battalion Operations. (TBP)
- FM 44-71. Air Defense Artillery Brigade Operations. (TBP)
- FM 44-80. Visual Aircraft Recognition. 20 July 1993.
- FM 44-100. US Army Air Defense Operations. 15 June 1995.
- FM 63-21. Main Support Battalion. 7 August 1990.
- FM 71-3. Armored and Mechanized Infantry Brigade. 11 May 1988.
- FM 71-100. Division Operations. 16 June 1990.
- FM 71-101(HTF). Infantry, Airborne, and Air Assault Division Operations. 26 March 1980.
- FM 90-3. Desert Operations. 24 August 1993.
- FM 90-4. Air Assault Operators. 16 March 1987.
- FM 90-5(HTF). Jungle Operations. 16 August 1982.
- FM 90-6. Mountain Operations. 30 June 1980.
- FM 90-10(HTF). Military Operations on Urbanized Terrain (MOUT). 15 August 1979.
- FM 90-10-1. An Infantryman's Guide to Combat in Built-Up Areas. 12 May 1993.
- FM 90-13. River Crossing Operations. 30 September 1992.
- FM 90-14. Rear Battle. 10 June 1985.
- FM 90-26. Airborne Operations. 18 December 1990.
- FM 100-2-1. Soviet Army Operations and Tactics. 16 July 1984.
- FM 100-2-2. The Soviet Army: Specialized Warfare and Rear Area Support. 16 July 1984.

FM 44-44

FM 100-2-3. The Soviet Army Troops, Organization, and Equipment. 6 June 1991.

FM 100-5. Operations. 14 June 1993.

FM 100-10. Combat Service Support. 18 February 1988.

FM 100-28. Doctrine and Procedures for Airspace Control in the Combat Zone. 1 December 1975.

FM 100-103. Army Airspace Command and Control in a Combat Zone. 7 October 1987.

FM 100-103-1. (ICAC³) Multiservice Procedures for Integrated Combat Airspace Command and Control. 30 October 1994.

FM 101-5-1. Operational Terms and Symbols. 21 October 1985.

GTA 17-2-19. Visual Signals for Armored Fighting Vehicles (Combined Arms).

Joint Publication 1-01. Joint Publication System, Joint Doctrine and Joint Tactics, Techniques, and Procedures Development Program. 14 September 1993.

Joint Publication 1-02. Department of Defense Dictionary of Military and Associated Terms. 23 March 1994.

Joint Publication 3-01.2. Joint Doctrine for Theater Counterair Operations. 1 April 1986.

(O)Joint Publication 3-01.3. Joint Doctrine for Air Defense From Oversea Land Areas. 23 May 1964.

Joint Publication 3-01.4. JTTP for Suppression of Enemy Air Defenses (J-SEAD). 3 December 1993.

Joint Publication 3-01.5. Doctrine for Joint Theater Missile Defense. 30 March 1994.

Joint Publication 3-52. Doctrine for Joint Airspace Control in a Combat Zone, 3 December 1993.

(O)TB 9-380-101-16. Security Classification Guide for Air-to-Air Stinger Basic/Post/RMP Guided Missile System. 3 August 1992.

(C)TB 380-6-7. Electrical Security (ELSEC) for Artillery Battlefield Survivability (U). 8 September 1981.

TM 3-216. Technical Aspects of Biological Defense. 12 January 1971.

References-4

TM 9-1425-429-12. Operator's and Organizational Maintenance Manual for Stinger Guided Missile Consisting of Weapon Round Basic, Round Post, Weapon Round RMP, Training Handling Guided Missile Launcher M60, Interrogator Set AN/PXX-3A, AN/PXX-3B, Interrogator, Set Programmer AN/G-5X-1, AN/GSX-1A (Stinger Guided Missile System). 21 April 1992 (Change 1, 30 October 1992).

TM 9-1425-433-10. Operator's Manual for Guided Missile Battery Control Central, Vehicle Mounted Pedestal Mounted Stinger Air Defense Weapon System. 30 March 1989 (Change 6, 21 December 1993).

TM 9-1450-1431-14&P. Operator and Maintenance Instructions With Illustrated Parts Breakdown Field Level for Guided Missile Coolant Recharging Unit GCU-31A/E. 1 June 1993.

TM 9-6920-429-12. Operator's and Organizational Maintenance Manual for Training Set, Guided Missile System, MI 34 (Stinger Air Defense Guided Missile System). 31 March 1992.

TM 43-0003-23. Demilitarization Procedures for Stinger Air Defense Guided Missile System. 14 April 1986.

TM 55-1425-429-14. Transportability Guidance, for Stinger Weapon System. 15 February 1981.

These international agreements are available on request from the Naval Publications and Forms Center, 5801 Tabor Avenue, Philadelphia, PA 19120. Use DD Form 1425 to requisition documents.

STANAG	TITLE	EDITION
2014	Operation Orders, Warning Orders, and Administrative/Logistics Orders	7
2019	Military Symbols for Land Based Systems—APP-6	3
2034	Land Forces Procedures for Allied Supply Transactions	4
2041	Operation Orders, Tables and Graphs for Road Movement	4
3700	NATO Tactical Air Doctrine-ATP-33(B)	4
3736	Offensive Air Support Operations—ATP-27(B)	8

FM 44-44

3805	Doctrine and Procedures for Airspace Control in Times of Crisis and War—ATP-40(A)	4
3880	Counter Air Operations—ATP-42(B)D	2

READINGS RECOMMENDED

These readings contain relevant supplemental information.

AR 385-64. Ammunition and Explosives Safety Standards. 22 May 1987.

FM 5-30. Engineer Intelligence. 22 September 1967 (Change 1, 1 October 1991).

FM 6-121. Tactics, Techniques, and Procedures for Field Artillery Target Acquisition. 25 September 1990.

FM 7-8. Infantry Rifle Platoon and Squad. 22 April 1992.

FM 8-10. Health Service Support in a Theater of Operations. 1 March 1991.

FM 8-10-6. Medical Evacuation in a Theater of Operations, Tactics, Techniques, and Procedures. 31 October 1991 (Change 1, 8 March 1994).

FM 8-50. Prevention and Medical Management of Laser Injuries. 8 August 1990.

FM 8-55. Planning for Health Service Support. 9 September 1994.

FM 8-285. Treatment of Chemical Agent Casualties and Conventional Military Chemical Injuries. 28 February 1990.

FM 9-38. Conventional Ammunition Unit Operations. 2 July 1993,

FM 9-59. Maintenance Operations for Air Defense and Land Combat Weapon Systems. 8 March 1994.

FM 10-27. General Supply in Theaters of Operations. 20 April 1993.

FM 10-52. Water Supply in Theaters of Operations. 11 July 1990.

FM 10-67. Petroleum Supply in Theaters of Operations. 16 February 1983 (Change 1, 1 October 1985).

FM 10-280. Mobile Field Laundry, Clothing Exchange, and Bath Operations. 22 October 1986.

FM 11-23. Theater Communications Command (Army). 28 November 1972.

References-6

- FM 12-6. Personnel Doctrine. 9 September 1994.
- FM 14-6. Resource Management Operations. 29 September 1994.
- FM 14-7. Finance Operations. 17 August 1994 (Change 1, 30 September 1994).
- FM 19-30. Physical Security. 1 March 1979.
- FM 21-10. Field Hygiene and Sanitation. 22 November 1988.
- FM 21-11. First Aid for Soldiers. 27 October 1988 (Change 2, 4 December 1988).
- FM 21-76. Survival. 5 June 1992.
- FM 22-9. Soldier Performance in Continuous Operations. 12 December 1991.
- FM 22-100. Military Leadership, 31 July 1990.
- FM 24-33. Communications Techniques: Electronic Counter-Countermeasures. 17 July 1990.
- FM 41-10. Civil Affairs Operations. 11 January 1993.
- FM 46-1. Public Affairs Operations. 23 July 1992.
- FM 55-1. Army Transportation Services in a Theater of Operations. 30 November 1984.
- FM 55-10. Movement Control in a Theater of Operations. 8 December 1992.
- FM 55-15. Transportation Reference Data. 9 June 1986.
- FM 55-30. Army Motor Transport Units and Operations. 14 March 1980 (Change 3, 19 October 1993).
- FM 55-50. Army Water Transport Operations. 30 September 1993.
- FM 57-38. Pathfinder Operations. 9 April 1993.
- FM 63-3. Corps Support Command. 30 September 1993.
- FM 71-1. Tank and Mechanized Infantry Company Team. 22 November 1988.
- FM 71-2. The Tank and Mechanized Infantry Battalion Task Force. 27 September 1988 (Change 1, 17 August 1994).
- FM 71-3. Armored and Mechanized Infantry Brigade. 11 May 1988.

FM 44-44

FM 71-123. Tactics and Techniques for Combined Arms Heavy Forces: Armored Brigade, Battalion/Task Force, and Company/Team. 30 September 1992.

FM 101-10-1/2. Staff Officers Field Manual-organizational, Technical, and Logistical Data Planning Factors. 7 October 1987 (Change 1, 17 July 1990).

STP 21-1-SMCT. Soldier's Manual of Common Tasks Skill Level 1. 1 October 1994.

INDEX

A

- AADC, 2-24, 3-4
- active air defense, B-1, B-2
- additional control measures, 2-23, 2-24
- aerial reconnaissance, C-1
- aerial resupply, 6-1, 6-6, 6-7
 - landing and pickup zones, 6-7
 - airdrops, 6-6, 6-7
 - airland, 6-6, 6-7
- aerial slingload, 6-7
- agility, 1-2, 5-6
- airspace control measures, 2-23, 2-24, 2-25, 5-12
- air and ground direct fire control measures, 2-20 thru 2-22
- air defense orders and annexes, A-1 thru A-8
- air defense warning (ADW), 2-17, 2-18; E-5
 - Red, 2-17
 - White, 2-17
 - Yellow, 2-17
- air IPB process, I-1
- air liaison officer (ALO), 2-5, 2-6
- air route, 2-24
- ammunition, 1-7, 1-8, 2-9, 5-7
 - 6-3, 6-6, 6-8, A-4, D-4, D-7, D-8, D-10, D-11, D-12, F-2, F-3, F-6, H-2, K-2, K-3, L-10, L-12
- attachment, 2-1
- autonomous operations, 2-20, K-4
- Avenger and forms of tactical offensive operations, 4-0, 4-6
- Avenger characteristics and capabilities, 1-2, 1-3, 1-6 thru 1-11, K-1
 - components, 1-7, 1-8, 1-9
 - control measures, 2-15, 2-17, 2-20, 2-21, 2-23, 2-24, 2-25, 4-8, 5-7, 5-12, J-1 thru J-7, L-3, L-4
- Avenger coverage in a defense in sector, 4-0, 4-15
- Avenger heavy characteristics, 1-3, 1-4
- Avenger in entry operations, 3-10, 3-11
 - breaching operations, 4-2, 4-3, 4-4, 4-5, 4-11
 - expansion/buildup, 3-12, 3-13, 3-15
 - reconnaissance operations, 4-0, 4-19
 - security operations, 4-0, 4-19
 - the offense, 4-0, 4-2, 4-12
- Avenger planning considerations, in the defense, 4-0, 4-12
- Avenger platoon, section, and squad checklists, D-1
 - platoon command post checklist, D-8, D-9
 - platoon coordination checklist, D-7, D-8
 - platoon leader's planning checklist, D-3, D-4
 - position occupation checklist, D-6, D-7, J-1
 - section/squad leader's briefing checklist, D-6
- Avenger platoon operations and

organization, 1-1 thru 1-4
Avenger platoon personnel
responsibilities, 1-4, 1-5
Avenger safety precautions, L-1,
L-9

B

balanced fires, 2-11, 3-6
battlefield illumination, G-0, G-4,
G-5
biological defense, H-0, H-6
biological defensive actions, H-6
Bradley Stinger Fighting Vehicle
(BSFV), 4-2, 4-3, 4-4, 4-5

C

Cease Engagement, 2-19
Cease Fire, 2-19
chemical defense, H-0, H-5, H-6
cold weather operations, F-6, F-7
combat operations in varied
environments, F-1 thru F-7
combat orders, 2-6
combined arms for air defense,
B-1
command, control, and communi-
cations, 2-0
command and control, 1-5, 1-6,
1-9, 2-0, 2-1, 2-8, 2-24, 2-27
3-1, 3-4, 3-5, 3-17, 4-2, 4-8
4-12, 4-13, 4-15, 4-19, D-4,
D-5, D-6, D-11, E-1, E-2,
E-5
command relationships, 2-1
communications, 1-5, 1-6, 2-0,
2-3, 2-6, 2-12, 2-20, 2-22,
2-23, 2-24, 2-26, 2-27, 2-28,
3-4, 4-9, 4-11, 5-0, 5-6, 5-8,
5-12, 6-7, A-1, A-4, B-1,
C-3, C-4, D-2, D-6, D-7,

D-11, D-16, E-1, E-6, F-1,
F-2, F-4, F-5, G-5, H-0, K-4,
L-11
communications equipment, 1-6,
2-26, 2-27, A-4, D-2
communications requirements,
2-0, 2-26
communications security, 2-28,
B-1, H-1
complete the plan, 2-13
concurrent planning process,
2-13, 2-14
conduct reconnaissance, 2-12, C-3
contamination avoidance, H-0
control during limited visibility,
G-0, G-5
control, 1-5, 1-6, 1-9, 2-0, 2-1,
2-2, 2-7, 2-8, 2-15, 2-17,
2-19, 2-20, 2-21, 2-23, 2-24,
2-25, 2-26, 2-27, 3-1, 3-4,
3-17, 4-2, 4-6, 4-8, 4-12,
4-13, 4-15, 4-19, 5-6, 5-7,
5-12, 6-2, 6-3, 6-4, 6-5,
6-6, 6-7, A-7, E-1, G-0, G-3,
G-5, H-6, I-3, J-1, J-2, K-1,
K-8, L-3, L-4,
control point, 2-24
counterattack, 4-0, 4-7, 4-17,
4-18, 5-2, 5-7
counter-RISTA, 3-1, 3-5, 3-6, 3-7,
3-8, 3-10, 3-11, 3-12, 3-13,
3-15, 3-18, 4-0, 4-2, 4-13,
4-14, 4-19, 4-20, 5-11, D-3
covering force operations, 4-0,
4-20, 4-21
cross-leveling, 6-1, 6-6, D-5, D-12
cruise missile (CM), 3-3 thru 3-7
3-10, 3-12, 3-15, 3-17

D

decisive operations, D-4
 decontamination, 2-5, 2-6, 5-11,
 D-2, D-8, D-9, H-0, H-1,
 H-5, H-6, H-9, H-10, H-11,
 L-10
 defense of a strong point, 4-0,
 4-16
 defensive actions,
 after a nuclear attack, H-2
 before a nuclear attack, H-2
 during a nuclear attack, H-2
 after a chemical attack, H-6
 before a chemical attack, H-5
 during a chemical attack, H-5
 deliberate attack, 4-8, D-3
 depth, 1-2, 2-11, 2-12, I-1, I-2
 desert operations, F-1, F-5
 digital early warning, 1-9, E-1,
 E-3
 directed early warning (DEW),
 2-15, 2-16, E-3, E-4
 direct support (DS), 2-2, 2-3, 2-9,
 4-2, 4-8, 4-10, 4-18,
 6-3 -
 Dynamite, 2-17, 2-18, E-4, E-5

E

early engagement, 2-10, 2-12,
 3-10, 3-13, 3-15, 4-11, 4-13,
 4-19, 5-11
 early warning (EW), 1-2, 1-9,
 2-15, 2-16, 2-18, 2-26, 3-3,
 3-5, 3-8, 3-9, 4-20, 5-12,
 C-4, D-4, D-6, D-9, D-10,
 E-1 thru E-6, F-2, G-6
 early warning (alerting and cue-
 ing) sensors, 2-15
 early warning networks, 2-16
 emission control (EMCON)
 measures, 2-23
 engage, 1-9, 2-18, 3-6, 3-15, 5-8,

 B-2, G-0, I-2, I-4, K-1
 thru K-9
 engagement principles, B-2
 engagement systems, B-5, K-1
 thru K-9
 engagement techniques, 2-20,
 B-2, B-5, D-17, K-2, K-3
 thru K-6
 engaging
 helicopters, K-3
 high-performance aircraft,
 K-2, K-3
 UAVs, K-3
 engineer, 2-6, 4-15, 4-16, 5-11,
 A-5, B-2, C-1, C-5, D-5,
 D-11, L-4
 entry operations, 3-1, 3-5, 3-8,
 3-9, 3-10, 3-11, 3-13, 3-19,
 environmental control unit (ECU),
 1-9
 EPLRS, 2-27, 2-28, E-1, E-2,
 E-5, E-6
 expansion/buildup operations,
 3-11, 3-12, 3-13, 3-15
 exploitation, 4-8

F

FAAD, 1-1, 2-25, 2-27, 3-1, 3-2,
 3-3, 3-5 thru 3-13, 3-15 thru
 3-19, 5-11, 5-13, 5-14, 5-15,
 5-18, 5-20, 5-21, 5-22, 5-23,
 5-24, D-4, E-5, E-6, K-3, K-4
 FAAD's role in force-projection
 operations, 3-1, 3-2
 fire control orders, 1-5, 2-19
 fire from remote emplacement,
 K-1, K-2
 fire on the move, K-1
 fire support officer (FSO), 2-6
 firing positions for small arms,
 B-5

FM 44-44

fixed-wing (FW) aircraft, 2-22,
3-3 thru 3-7, 3-10, 3-12,
3-15, 4-1, 4-12, E-6, K-5
force-projection operations, 3-1,
3-2, 3-4, 3-17
forward looking infrared (FLIR),
1-6, 1-7, 1-8, 1-9, 3-3, 4-10,
K-7, K-8
fragmentary order (FRAGO), 2-7,
2-8, 2-9, A-5, D-4, D-6, D-12

G

general support (GS), 2-2, 2-3,
4-2, 6-5
general support-reinforcing
(GS-R), 2-3, 4-2, 5-11, 6-5
global positioning system, G-2,
G-3, J-1
ground-based sensor (GBS), 1-9,
3-7, 3-8, 3-10, 3-11, 3-12,
3-15, E-5, F-4, K-3
ground reconnaissance 2-12, C-1,
C-4
gunner, 1-3, 1-5, 1-6, 1-8, 1-9,
2-19, 2-21, B-5

H

hasty attack, 4-7, 4-8, D-3
hazards, 1-9, 2-22, F-2, F-3, F-4,
H-1, L-3, L-4, L-9, L-10
health services support, 6-1, 6-8
high-density airspace control zone
(HIDACZ), 2-23
high-mobility multipurpose
wheeled vehicle (HMMWV),
1-3, 1-4, 1-6, 1-7, 1-10, 1-11,
E-6, K-2
HIMAD, 2-11
Hold Fire, 2-19
hostile criteria, 2-19, 5-17, A-4,
D-6, K-8

I

identification, friend or foe (IFF),
1-6, 1-8, 2-5, 2-19, E-5, E-6
initiate necessary movement,
2-12
initiative, 1-2, 2-15, 3-2, 4-0,
4-2, 5-6
invisible light, G-4
IPB, 2-4, 2-5, 2-6, 2-12, 2-14,
3-6, 3-7, 3-8, 3-10, 3-14,
3-18, 4-8, 4-12, 4-13, 4-15,
4-18, 4-19, 4-20, 5-9, 5-11,
A-2, D-3, D-7, I-1, I-2, I-3,
I-4, I-5
issue a warning order, 2-9
issue the operation order, 2-13

J

JFACC, 3-4
jungle operations, F-3, F-4

L

landing and pickup zones, 6-7
laser range finder (LRF), 1-6, 1-7,
1-8, K-2, K-6, K-7
lightweight and special divisions
interim sensor (LSDIS),
1-9, 3-6, 3-7, 3-10, 3-12,
3-15, E-2, E-6
limitations, 1-7, 1-9, 2-1, 2-11,
3-6, F-1, F-2
limited visibility operations, G-0
thru G-5
local air defense warning
(LADW), 2-17, 2-18, D-6,
D-11, E-1, E-4, E-5
logistics release point, 6-3
logistics, 1-4, 1-5, 2-1, 2-6, 2-8,
2-14, 2-23, 3-3, 3-4, 3-5,
3-11, 4-7, 4-8, 4-13, 4-15,
5-6, 5-12, 6-1, 6-2, 6-3, 6-6,
6-8, D-4, D-7, I-5

LOGPAC, 2-5, 6-1 thru 6-6
 LOGPAC operations by the battery headquarters, 6-1, 6-5
 LOGPAC operations by the supported force, 6-1, 6-3
 Lookout, 2-18
 low-altitude aerial threat, 3-1, 3-2, 3-3
 LRP, 6-3, 6-4, 6-5, 6-6

M

M3P .50-caliber machine gun, 1-6, 1-7, 1-8, K-6 thru K-9, L-10
 main supply route (MSR), 6-3, 6-4, 6-5
 make a tentative plan, 2-10
 MANPADS conversion, K-2
 MANPADS, 1-8, 1-9, 2-11, 3-10, 3-15, 3-16, 4-2, 4-10, 4-11, 4-15, 4-20, 4-21, F-1, K-2, L-12
 manual range estimation, K-6 thru K-9
 maps and control measures, J-1
 map reconnaissance, 2-13, C-0, C-1, C-2, C-3
 means of communications, 2-27, A-1
 meeting engagement, D-3
 methods of decontamination, H-9
 methods of reconnaissance, C-0
 METT-T, 1-3, 2-9, 2-12, 2-17, 2-26, 3-6, 3-8, 3-10, 3-18, 4-12, 4-15, 4-16, 5-8, 5-9, C-2, C-5, L-3
 minimum risk route (MRR), 2-23
 missile exhaust, L-10
 missile manual range estimation, K-6

mission-oriented protection posture, H-0, H-6
 MOPP levels, H-5, H-7 thru H-11
 mountain operations, F-1
 movement to contact, 3-3, 4-7, 4-8, 4-11, D-3
 mutual support, 2-11, 5-11, F-4

N

NAI, 2-4, 2-12, 2-15, 4-7, 4-8, I-4
 NBC, C-3, D-2, D-6, D-8, D-9, D-11, H-0, H-1, H-2, H-5, L-10
 nuclear
 defense, H-0 thru H-5
 first aid, H-2
 nuclear, biological, and chemical defense fundamentals, H-0, H-1
 operations, H-0 thru H-11

O

OCOKA, 2-9, 2-12, 4-16
 offense, 4-0, 4-1, 4-2, 4-12
 OPCODE, 2-1, 2-2
 operation order (OPORD), 2-4, 2-7, 2-8, 2-9, 2-10, 2-13, 2-14, 2-23, 6-8, C-1, C-3, D-4, D-6, D-8, D-10, H-10, L-8
 optical sight, 1-8
 organic, 1-3, 2-1, 2-2, 3-9, 6-5, A-3, D-10, D-11, E-5, E-6, G-1
 overlapping fires, 2-11, 3-8, 5-11, F-5

P

passage of lines, 5-12, 5-13, D-3
 passive air defense, 2-5, 2-17,

B-1, B-2, E-1
 perimeter defense, 4-0, 4-18
 personnel services, 6-1, 6-2, 6-7
 platoon, section, and squad limited visibility equipment, G-0
 platoon leader, 1-1 thru 1-5, 2-0, 2-2, 2-4 thru 2-13, 2-15, 2-21, 2-23, 2-26, 2-27, 3-4 thru 3-11, 4-2, 4-6, 4-7, 4-8, 4-10, 4-11, 4-13, 4-15, 4-18, 4-21, 5-1, 5-3, 5-9, 5-10, 5-13, 6-1 thru 6-6, 6-8, A-1, A-2, A-3, A-5, A-7, C-2 thru C-5, D-1, D-3, D-4, D-5, D-6, D-7, D-12, E-4, J-7, L-9
 platoon precombat inspection, D-2, D-3
 platoon sergeant, 1-3, 1-4, 1-5, 2-4, 2-5, 2-6, 2-12, 2-13, 6-1, 6-2, 6-4, 6-5, 6-8, C-5, D-1, D-4, D-5, J-1
 positive control measures, 2-15
 postconflict operations, 3-19
 precision lightweight GPS receiver (PLGR), G-2, G-3
 predecisive operations, D-4
 primary target line (PTL), 2-21, 2-22, C-3, D-6, D-10
 procedural control measures, 2-17,
 protection, 1-1, 1-8, 2-11, 2-12, 2-25, 3-2, 3-8, 3-10, 3-18, 4-0, 4-18, 4-20, 5-3, 5-8, 5-10, 5-13, A-3, B-1, B-5, C-3, C-5, F-1, F-2, H-0, H-1, H-2, H-6, H-7, I-2, L-0, L-10, L-12
 purpose of the offense, 4-0
 pursuit, 4-8

R

radiological contamination, H-5, H-10
 radio communications, 2-27, 2-28
 receive the mission, 2-8
 reconnaissance, selection, and occupation of position, C-0 thru C-6
 reconnaissance operations, 4-0, 4-19
 rehearse, execute, and supervise, 2-13
 reinforcing (R), 2-2, 2-3, 4-2, 4-11, 4-20, 6-3
 relief in place, 5-11, 5-12, 5-17
 remote control unit (RCU), 1-9, 4-10, K-1
 replacement operations, 6-1, 6-8
 restricted operations zone (ROZ), 2-24
 right of self-defense, 2-19
 risk assessment, 3-5, 3-6, 3-14, H-11, L-0 thru L-8
 RISTA, 1-1, 2-9, 2-24, 3-1, 3-2, 3-4 thru 3-8, 3-10 thru 3-13, 3-15 thru 3-19, 5-5, 5-11, A-2
 rotary-wing (RW) aircraft, 2-22, 3-4, 3-5, 3-6, 3-7, 3-10, 3-12, 3-15, 3-17, 3-18, 4-12, I-1
 rules of engagement (ROE), 1-5, 2-19, 3-5, 5-8, 5-12, D-6

S

S1, 2-4, 2-5, 6-4, D-7
 S2, 2-4, 2-5, D-7, I-1
 S3, 2-4, 2-5, 2-14, C-2, C-6, D-7, D-9
 safety and risk assessment, L-0 thru L-12

safety briefing checklist, L-11, L12
 scheme of maneuver, 2-4 thru 2-13, 3-6, 3-8, 4-2, 4-6, 4-8, 4-9, A-4, D-5, D-6
 section leader (driver)/squad leader (driver), 1-5
 sector of fire (SOF), 2-20, 2-21
 security operations, 4-0, 4-20, 4-21
 selecting a support relationship, 2-2
 simplified handheld terminal unit (SHTU), 1-9, E-6, K-3, K-4
 SINGGARS, 2-27, 2-28, E-1, E-6
 Snowman, 2-18, E-5
 staff coordination, 2-4
 standard use Army aviation flight route (SAAFR), 2-23
 standard vehicle mounted launchers (SVML), 1-6, 1-8
 STANO devices, G-1, G-2
 Stinger missile, 1-6, 3-7, 3-8
 synchronization, 1-2, 2-5, 3-3, 5-8

T

techniques of decontamination, H-11
 threat
 in entry operations, 3-10
 in expansion/buildup, 3-12
 in the defense, 4-0, 4-1
 in the offense, 4-0, 4-12
 operational assumptions, 3-1, 3-3
 troop-leading procedures, 2-8, A-1

U

unit maintenance collection point (UMCP), 6-3 thru 6-6, D-5
 unmanned aerial vehicle (UAV), 3-3 thru 3-8, 3-10 thru 3-19, I-1, I-2, I-3, K-3, K-5

V

vehicle movements and convoys, L-4, L-11, L-12
 versatility, 1-3, 3-3, 3-4
 visible light, G-4, G-5
 voice early warning, E-1, E-3

W

warning order (WARNO), 2-7, 2-9, 2-14, A-1, A-2, C-2, D-4
 weapon control status (WCS), 1-9, 2-17, 2-19, 2-20, 2-23, 5-12, A-7, D-6, D-8, D-10, D-11, E-6, K-8
 weapons engagement zone, 2-25
 WEAPONS FREE, 2-19, 2-20, A-2
 weapons free zone (WFZ), 2-25
 WEAPONS HOLD, 2-19, 2-20
 WEAPONS TIGHT, 2-19, 2-20
 weapon selection criteria, K-2, K-3
 weighted coverage, 2-11, 2-12, 3-6
 wire communications, 2-27, F-4

FM 44-44
3 October 1995

By Order of the Secretary of the Army:

Official:

JOEL B. HUDSON

*Acting Administrative Assistant to the
Secretary of the Army*
00810

DENNIS J. REIMER
*General, United States Army
Chief of Staff*

Distribution:

Active Army, USAR, and ARNG: To be distributed in accordance with DA Form 12-11 E, Requirements for FM 44-44, *Avenger Platoon, Section, and Squad Operations* (Qty rqr block no. 4881).